

**XTRA dimensions**

■ Drawings below are reference examples only.  
DXF/DWG/PDF drawings available on our website.

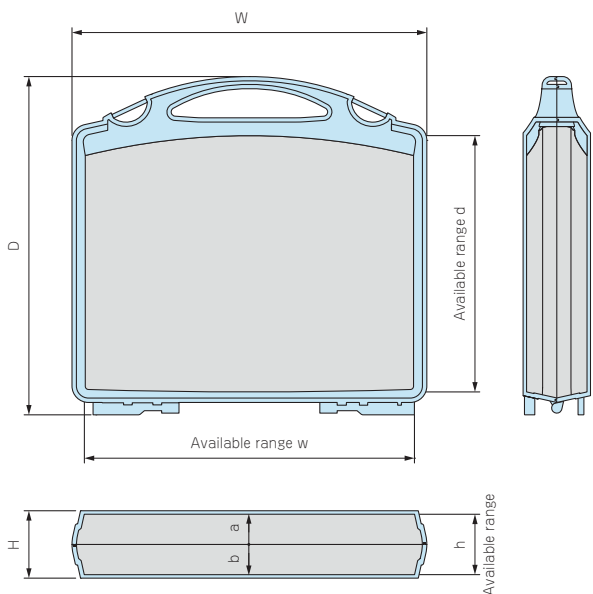

**Product no. / Dimensions**

Product no.		Dimensions (External)			Dimensions (Internal)					Weight (kg)
● Black	● Light gray	W	D	H	w	d	h	a	b	
XTRA 262505 B	XTRA 262505 G	258	246	49	240	188	42	21	21	0.4
XTRA 323108 B	XTRA 323108 G	320	308	81	296	230	76	38	38	0.6
XTRA 403810 B	XTRA 403810 G	397	377	96	368	290	90	45	45	0.9
XTRA 494614 B	XTRA 494614 G	486	460	136	450	355	131	65.5	65.5	1.66

**Accessories (Optional parts)**

**XTSP SERIES FOAM SET for MINI**



- Pre-cubed polyurethane foam can be easily cut to make a suitable storage space.
- Available as a three-layered foam set with waved (for cover side), Pre-cubed foam (for base side) and base layer.
- DXF/DWG/PDF drawings available on our website.

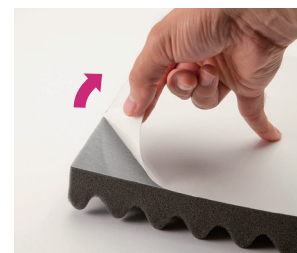
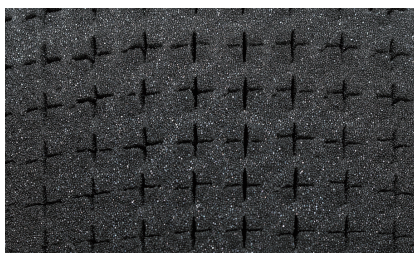

**Product no. / Suitable case**

Product no.	Suitable case	Foam layer details	Cut-line pitch
XTSP 2625	XTRA 262505 B/G	Waved layer x 1 · Pre-cubed foam layer x 1 · Base layer x 1	15mm
XTSP 3231	XTRA 323108 B/G	Waved layer x 1 · Pre-cubed foam layer x 1 · Base layer x 1	15mm
XTSP 4038	XTRA 403810 B/G	Waved layer x 1 · Pre-cubed foam layer x 1 · Base layer x 1	15mm
XTSP 4946	XTRA 494614 B/G	Waved layer x 1 · Pre-cubed foam layer x 1 · Base layer x 1	20mm

Both waved and base layer has a double-sided tape attached on the back side. Peel off to adhere onto the inner side of the case.