

# IP67 UV-PROTECT NETWORK PLASTIC BOX WP SERIES

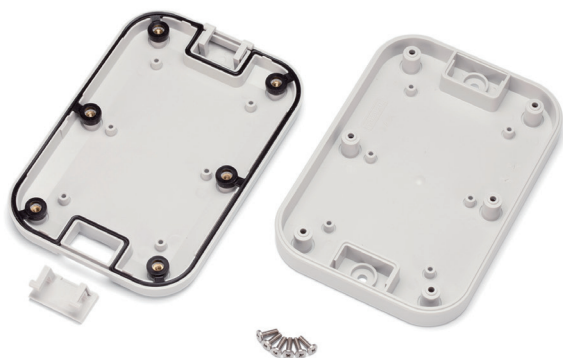

## Waterproofing ability by using silicone gasket

Highly elastic and durable silicone gasket for high waterproof ability. The use of insert nuts allows the unit to retain its waterproof ability even after multiple opening and closing.



## Weather-resistant ASA material

The white gray "G" type utilize a UV resistant, durable ASA material. Recommended for outdoors usage as a communication device type equipment.

### Outdoors Use Example

IT Sensor Data Logger for agriculture  
Product by Nishimu Electronics Industries Co., Ltd.  
Website : [nishimu.co.jp/index-e.html](http://nishimu.co.jp/index-e.html)



## Easy installation on walls and brackets

Easy mounting onto walls and brackets by opening the blind lids. A clean and sleek appearance can be maintained as screws are hidden away by the blind lids.



## Easy installation on electrical poles

By using a pole mounting accessory, it can be attached to poles with ease.



## How to make buttons and switches waterproof

Utilize a waterproof membrane keypad, membrane switch or overlay.

Note that the waterproof performance will be lost once holes or cutouts for buttons and/or switches drilled/machined on waterproof enclosures.



Product by Arrow7 (Japan)

## How to make waterproof buttons and switches

Please utilize a waterproof membrane keypad, membrane switch or overlay.

Note that the waterproof performance will be lost by drilling/milling holes or cutouts for buttons or switches on waterproof enclosures.



Please utilize a waterproof membrane keypad, membrane switch or overlay.

Note that the waterproof performance will be lost by drilling/milling holes or cutouts for buttons or switches on waterproof enclosures.

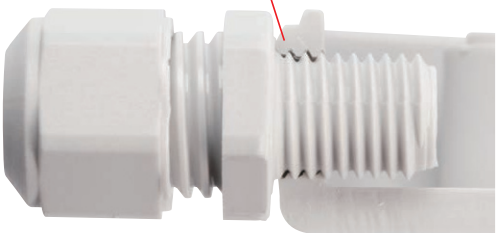
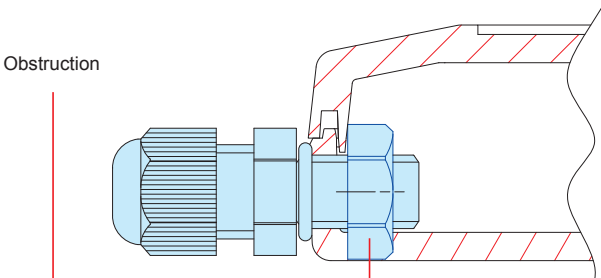
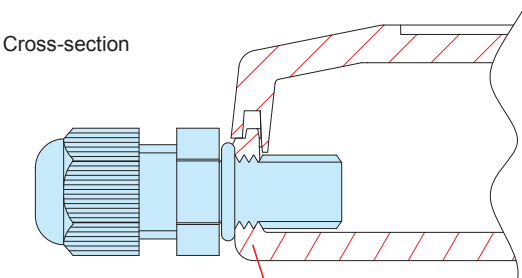

Thread hole milling from M6 ~ M32 sizes can be drilled as per your requirements.



# WP SERIES

# APPLICATION EXAMPLE



## LeakLess Monitor - Industrial Pressure/Flow Data Logger



## Leak Guard - Home Water Leak Detector

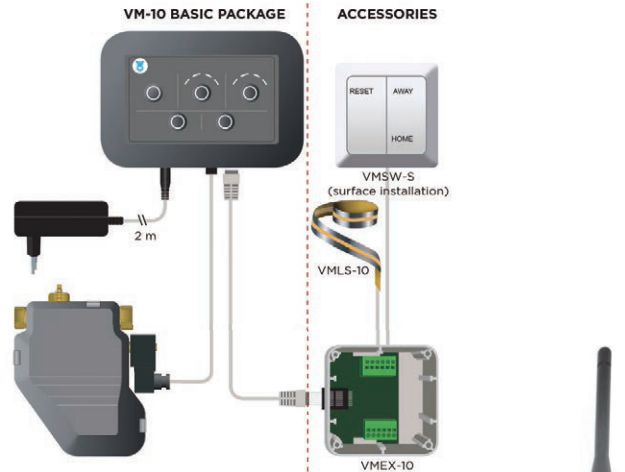

## Wireless Temperature/Humidity Transmitter

Product by Masibus Automation And Instrumentation (India)



## LoRaWAN Network Air Pressure Sensor



Product by mcf88 (Italy)

## Sigfox Remote Surveillance Sensor



Product by SpaceAge Labs (Singapore)

## Network Sensor for Agriculture

Product by Demand Side Instruments (France)



## Remote Sprinkler Control Unit



Product by Demand Side Instruments (France)

## Argonomic Parameter Surveillance Unit LoRa Gateway

Product by  
Argotec Engineering (Spain)



## Maritime GPS Tracking System

Product by HidnSeek (France)





- IP67 protection class allows the unit to be used outdoors while protecting the internal components from dust and water.
- Available in 2 types : UV-resistant ASA in white gray color, and flame-resistant ABS in charcoal gray color.
- Addition of 8 sizes for a total of 24 different selectable sizes.
- Mount on walls or brackets by simply opening the blind lids.
- Pole mounting is possible via an optional pole mounting bracket accessory.



Technical Data	
Protection class :	IP67
Operating temperature :	ASA* -30 ~ +60°C
	ABS -20 ~ +50°C

\*May become brittle and break under impact when temperature is lowered close to -30°C.

WP5-7-2 ~ WP13-18-5

WP15-15-4 ~ WP20-28-7

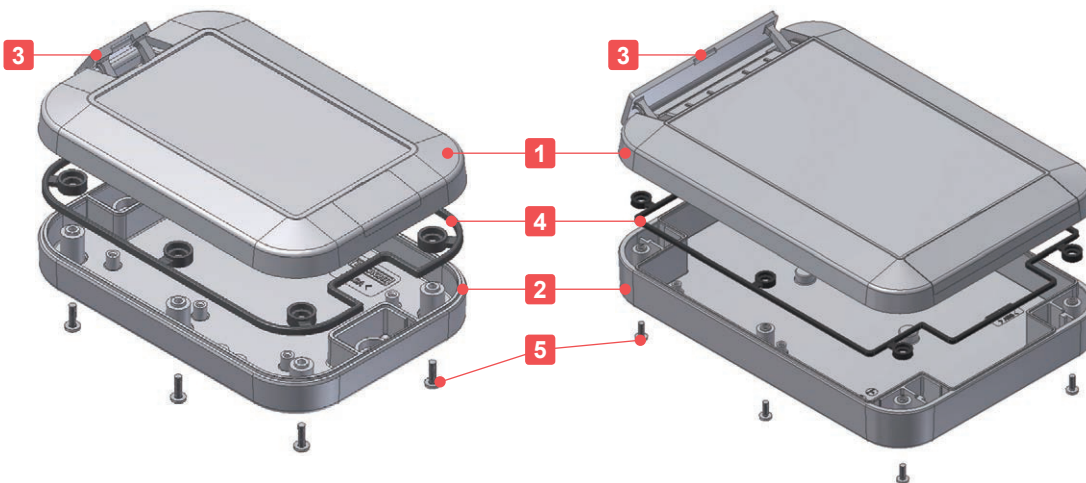

Components

No.	Part name	Pcs	Material / Color
1	Top cover	1	ASA UL94HB / White gray : Flame-resistant ABS UL94V-0 / Charcoal gray
2	Bottom base	1	ASA UL94HB / White gray : Flame-resistant ABS UL94V-0 / Charcoal gray
3	Blind lids	2	ASA UL94HB / White gray : Flame-resistant ABS UL94V-0 / Charcoal gray
4	Gasket	1	Silicone / Black
5	Screw	4 ~ 8	Stainless steel binding head screw / Unfinished

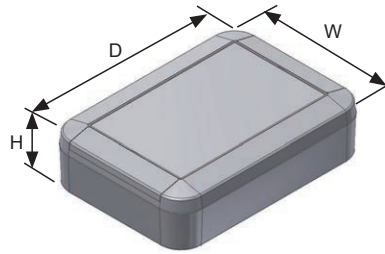

Product no. / Dimensions

Product no.		Dimensions			Weight (g)	Screw	Recommended torque (N · m)	
● White gray (ASA)	● Charcoal gray (ABS)	W	D	H			Box Assembling	PCB Mounting
WP 5- 7-2G	WP 5- 7-2C	52	65	18	31.5	M2-8 x 4 pcs	0.2 ~ 0.25	0.12 ~ 0.15
WP 5- 7-3G	WP 5- 7-3C	52	65	27	39.5	M2-8 x 4 pcs	0.2 ~ 0.25	0.12 ~ 0.15
WP 6- 8-2G	WP 6- 8-2C	60	80	20	41.5	M2-8 x 4 pcs	0.25 ~ 0.3	0.12 ~ 0.15
WP 6- 8-3G	WP 6- 8-3C	60	80	30	49	M2-8 x 4 pcs	0.25 ~ 0.3	0.12 ~ 0.15
WP 8- 8-2G	WP 8- 8-2C	75	75	22	57.5	M2.5-8 x 4 pcs	0.25 ~ 0.35	0.12 ~ 0.15
WP 8- 8-4G	WP 8- 8-4C	75	75	35	88.5	M2.5-16 x 4 pcs	0.25 ~ 0.35	0.12 ~ 0.15
WP 8-10-2G	WP 8-10-2C	75	100	22	74	M2.5-8 x 4 pcs	0.25 ~ 0.35	0.12 ~ 0.15
WP 8-10-4G	WP 8-10-4C	75	100	35	95	M2.5-16 x 4 pcs	0.25 ~ 0.35	0.12 ~ 0.15
WP 9-13-3G	WP 9-13-3C	90	130	25	113	M2.5-8 x 6 pcs	0.25 ~ 0.35	0.2 ~ 0.25
WP 9-13-4G	WP 9-13-4C	90	130	40	141	M2.5-16 x 6 pcs	0.25 ~ 0.35	0.2 ~ 0.25
WP10-10-3G	WP10-10-3C	100	100	25	96	M2.5-8 x 4 pcs	0.25 ~ 0.35	0.2 ~ 0.25
WP10-10-4G	WP10-10-4C	100	100	40	121	M2.5-16 x 4 pcs	0.25 ~ 0.35	0.2 ~ 0.25
WP11-15-3G	WP11-15-3C	110	150	27	153	M2.5-8 x 6 pcs	0.25 ~ 0.35	0.2 ~ 0.25
WP11-15-4G	WP11-15-4C	110	150	40	181	M2.5-16 x 6 pcs	0.25 ~ 0.35	0.2 ~ 0.25
WP13-18-3G	WP13-18-3C	130	175	30	225	M2.5-8 x 6 pcs	0.25 ~ 0.35	0.2 ~ 0.25
WP13-18-5G	WP13-18-5C	130	175	45	266	M2.5-16 x 6 pcs	0.25 ~ 0.35	0.2 ~ 0.25
<b>NEW</b> WP15-15-4G	<b>NEW</b> WP15-15-4C	150	150	40	239	M3-8 x 4 pcs	0.35 ~ 0.45	0.2 ~ 0.3
<b>NEW</b> WP15-15-6G	<b>NEW</b> WP15-15-6C	150	150	55	282.5	M3-8 x 4 pcs	0.35 ~ 0.45	0.2 ~ 0.3
<b>NEW</b> WP15-21-4G	<b>NEW</b> WP15-21-4C	150	210	40	323	M3-8 x 6 pcs	0.35 ~ 0.45	0.2 ~ 0.3
<b>NEW</b> WP15-21-6G	<b>NEW</b> WP15-21-6C	150	210	55	367.5	M3-8 x 6 pcs	0.35 ~ 0.45	0.2 ~ 0.3
<b>NEW</b> WP20-20-5G	<b>NEW</b> WP20-20-5C	200	200	45	434	M3-8 x 8 pcs	0.35 ~ 0.45	0.2 ~ 0.3
<b>NEW</b> WP20-20-7G	<b>NEW</b> WP20-20-7C	200	200	65	505	M3-8 x 8 pcs	0.35 ~ 0.45	0.2 ~ 0.3
<b>NEW</b> WP20-28-5G	<b>NEW</b> WP20-28-5C	200	280	45	557.5	M3-8 x 8 pcs	0.35 ~ 0.45	0.2 ~ 0.3
<b>NEW</b> WP20-28-7G	<b>NEW</b> WP20-28-7C	200	280	65	646	M3-8 x 8 pcs	0.35 ~ 0.45	0.2 ~ 0.3

■ Recommended torque listed is for reference only; actual may differ. Assemble after testing torque.

■ G color type shall undergo a revision. Color shall change from "White gray - RAL7035" to "Munsell N8.75 or similar".



Accessories (Optional parts)



**WP dimensions**

■ Drawings below are reference examples only.  
DXF/DWG/PDF drawings available on our website.

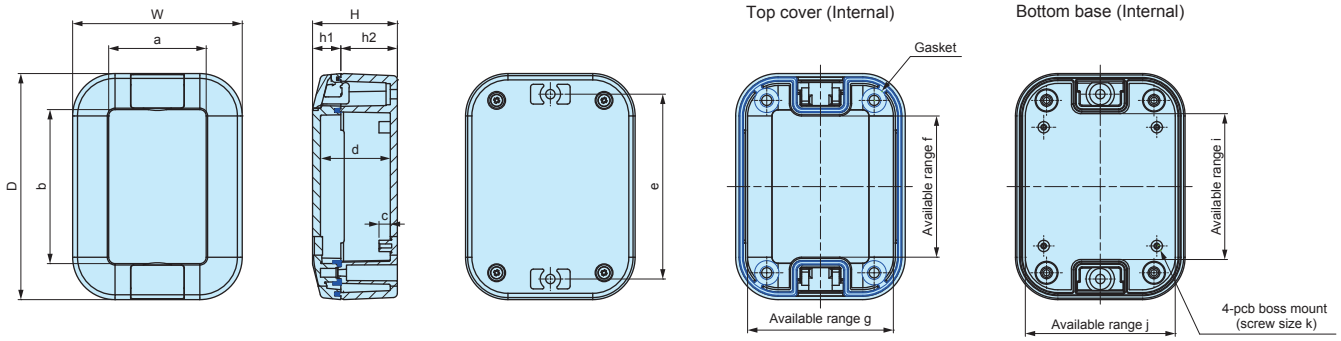

※Boss for PCB are located inside top covers of certain models. Detailed information available on DXF/DWG/PDF drawings.

Product no.	W	D	H	h1	h2	a	b	c	d	e	f	g	i	j	k
WP 5- 7-2	52	65	18	10	8	26.5	38.8	4	13	50.6	34.5	43.5	37	46	M2
WP 5- 7-3	52	65	27	10	17	26.5	38.8	4	22	50.8	34.5	43.5	36.5	45	M2
WP 6- 8-2	60	80	20	10	10	34.5	53.8	4	14.7	65.8	50	51.5	52	53.5	M2
WP 6- 8-3	60	80	30	10	20	34.5	53.8	4	24.7	65.4	50	51.5	51	53	M2
WP 8- 8-2	75	75	22	10	12	49.5	48.8	4	16.4	60.6	44	66	42	67	M2
WP 8- 8-4	75	75	35	10	25	49.5	48.8	4	29.4	60.4	43	66	42	66	M2
WP 8-10-2	75	100	22	10	12	46	71	4	16	85.6	69	66	67	67	M2
WP 8-10-4	75	100	35	10	25	46	71	4	29	85.4	69	66	67	66	M2
WP10-10-3	100	100	25	12	13	63.8	63.7	4.5	18	81.2	60	89	61	90	M2.3
WP10-10-4	100	100	40	12	28	63.8	63.7	4.5	33	81	60	89	61	90	M2.3

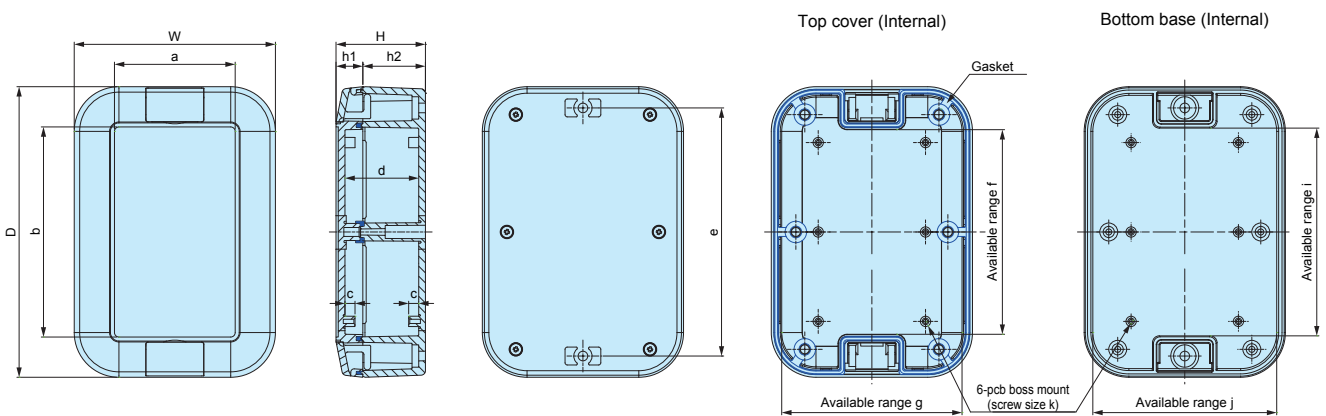

Product no.	W	D	H	h1	h2	a	b	c	d	e	f	g	i	j	k
WP 9-13-3	90	130	25	12	13	53.8	93.7	4.5	18	111.2	90	79	91	81	M2.3
WP 9-13-4	90	130	40	12	28	53.8	93.7	4.5	33	111	90	79	91	81	M2.3
WP11-15-3	110	150	27	12	15	73.7	113.5	4.5	20	131.2	110	99	110	100	M2.3
WP11-15-4	110	150	40	12	28	73.7	113.5	4.5	33	131	110	99	110	100	M2.3
WP13-18-3	130	175	30	12	18	93.8	138.8	4.5	23	156.2	136	120	135	120	M2.3
WP13-18-5	130	175	45	12	33	93.8	138.8	4.5	38	156.2	136	120	135	120	M2.3

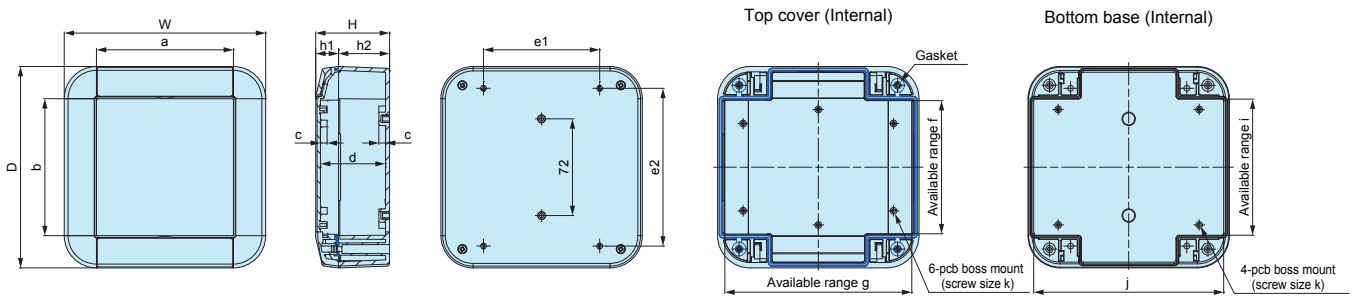

Product no.	W	D	H	h1	h2	a	b	c	d	e1	e2	f	g	i	j	k
WP15-15-4	150	150	40	17	23	102	102	5	33.5	86.5	117.5	99	139	100	141	M2.6
WP15-15-6	150	150	55	17	38	102	102	5	48.5	86.5	117.5	99	139	100	140	M2.6

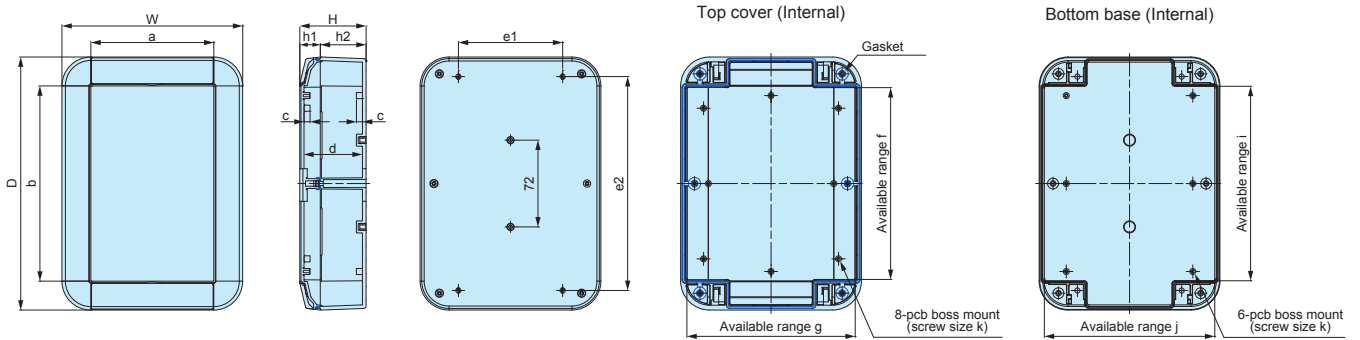

Product no.	W	D	H	h1	h2	a	b	c	d	e1	e2	f	g	i	j	k
WP15-21-4	150	210	40	17	23	102	162	5	33.5	86.5	177.5	159	139	160	141	M2.6
WP15-21-6	150	210	55	17	38	102	162	5	48.5	86.5	177.5	159	139	160	140	M2.6

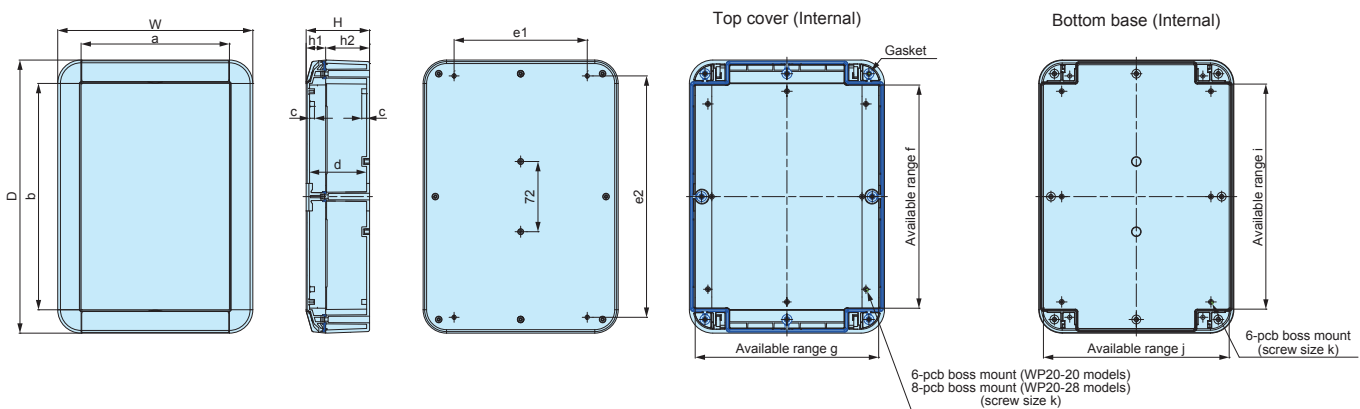

Product no.	W	D	H	h1	h2	a	b	c	d	e1	e2	f	g	i	j	k
WP20-20-5	200	200	45	20	25	152	152	5	38.5	136.5	167.5	148	187	150	190	M2.6
WP20-20-7	200	200	65	20	45	152	152	5	58.5	136.5	167.5	148	187	149	189	M2.6
WP20-28-5	200	280	45	20	25	152	232	5	38.5	136.5	247.5	227	187	230	190	M2.6
WP20-28-7	200	280	65	20	45	152	232	5	58.5	136.5	247.5	227	187	229	189	M2.6



# WEATHERBILITY / DURABILITY TEST DATA for IP rated boxes

**Weather resistance is the ability of a material to prevent corrosion, loss of material or any sort of deterioration due to prolonged exposure to harsh environmental and weather conditions.**

**The test data for our weather resistance waterproof/dustproof cases are as detailed below.**

## TEST DETAILS • TEST INSTRUMENT

Tester : Super Xenon Weather Meter SX75 - Suga Test Instruments Co., Ltd.  
 (Testing under conditions closest to the spectral distribution of sunlight by utilizing a xenon lamp and filter system.)

Irradiation Condition : 180 W/m<sup>2</sup> at 300 ~ 400nm

Black panel humidity : 63±3 °C

Relative Humidity : 50±10 %

Cycle conditions : 120 minutes (18 min. irradiation + water spray and 102 min. irradiation)

Test Time : 500 hours (continuous test)

Radiation Exposure : 324 MJ/m<sup>2</sup>

Measurements : Color measurements performed based upon JIS Z 8722 standard, with the results based upon JIS Z8781-4 standard.  
 \*Lesser color difference infers better weather resistance.

## TEST DATA

\*Test data results are reference data only; does not reflect actual usage conditions.

**Before testing (plastic material color)**



①                      ②                      ③                      ④                      ⑤                      ⑥



**After 500 hours testing (plastic material color)**



No.	Target box / Material	Test time	Color difference ΔEab
①	WP series - G color type ASA material	100 hrs.	0.9
		500 hrs.	3.3
②	SPCP • SPCM series (Body) Glassfiber-filled Polycarbonate material	100 hrs.	2.9
		500 hrs.	7.8
③	BCPC • BCPK series (Top cover) Polycarbonate material	100 hrs.	3.8
		500 hrs.	7.9
④	BCPC • BCPK series (Base) Glassfiber-filled Polycarbonate material	100 hrs.	4.7
		500 hrs.	8.6
⑤	SPCP • SPCM series (Cover) Polycarbonate material	100 hrs.	3.7
		500 hrs.	10.6
⑥	BCAP series ABS material	100 hrs.	3.6
		500 hrs.	10.8

**Better weather resistance**



WPMB SERIES

POLE MOUNT BRACKET

← NEW SIZE



- Pole mount bracket made from weather resistant ASA material.
- Hole milling is not required when installing the mount bracket, thus allowing the enclosure to maintain its IP67 protection.
- WPMB-M4-2 can be used both for vertical and horizontal installation.
- Together with WPMB series, the PKB series mounting belt enables the unit to be mounted onto a pole.
- DXF/DWG/PDF drawings available on our website.

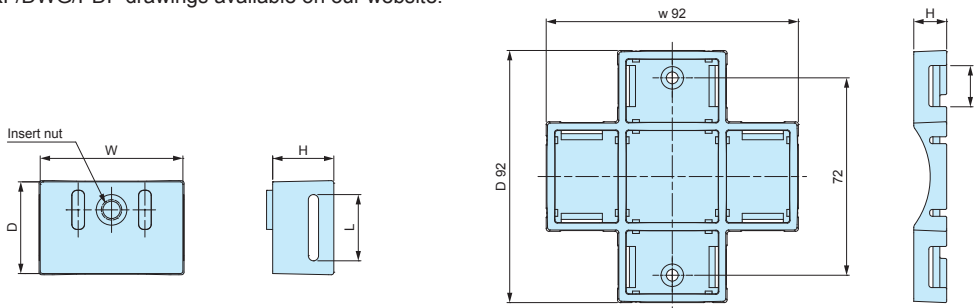

Color Type

Code	Color
G	White gray
D	Dark Gray

WPMB-M3 □ WPMB-M4

WPMB-M4-2

Product no. / Dimensions

■ Please suffix color code at the end of the product number.

Product no.	Dimensions				Material / Finish	Screw	Suitable enclosures	Recommended torque (N · m)	Weight (g)	Pack of
	W	D	H	L						
WPMB-M3 □	18	14	9.5	11	ASA UL94HB	Stainless steel M3-6 x 2 pcs	WP5-7-2 • 5-7-3 • 6-8-2 • 6-8-3 • 8-8-2 • 8-8-4 • 8-10-2 • 8-10-4	0.4 ~ 0.45	3	2 (pair)
WPMB-M4 □	28	18	12	13	ASA UL94HB	Stainless steel M4-8 x 2 pcs	WP9-13-3 • 9-13-4 • 10-10-3 • 10-10-4 • 11-15-3 • 11-15-4 • 13-18-3 • 13-18-5	0.45 ~ 0.5	10	2 (pair)
<b>NEW</b> WPMB-M4-2 □	92	92	12	13	ASA UL94HB	Stainless steel M4-6 x 2 pcs	WP15-15-4 • 15-15-6 • 15-21-4 • 15-21-6 • 20-20-5 • 20-20-7 • 20-28-5 • 20-28-7	0.45 ~ 0.5	24	1

■ Recommended torque listed is for reference only; actual may differ. Assemble after testing torque.

WPMB-M3/WPMB-M4

WPMB-M4-2

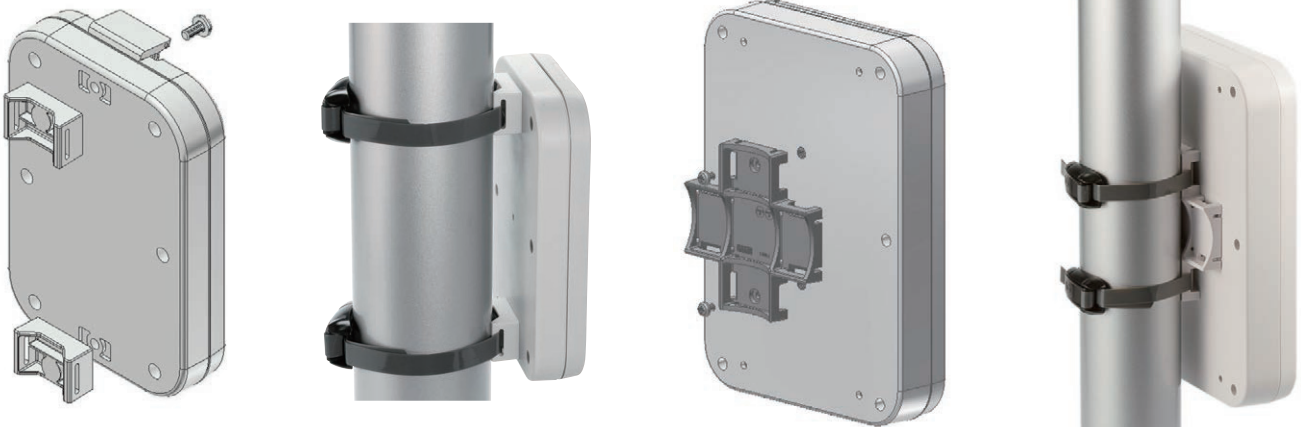



PKB-10PM, 10P



PKB-10S, 20S

- New shorter belt type PKB-10PM is available for  $\phi 25$  to  $\phi 60$ mm poles. Other belt types are for  $\phi 60$  to  $\phi 400$ mm poles.
- Designed for one time use only (not reusable).
- Strong stainless steel clamping type and easy installation plastic type are available.
- Use SSK mounting bracket for installation onto a pole.
- Drawings below are reference examples only. DXF/DWG/PDF drawings available on our website.

**PKB dimensions**

**PKB-10PM, 10P**

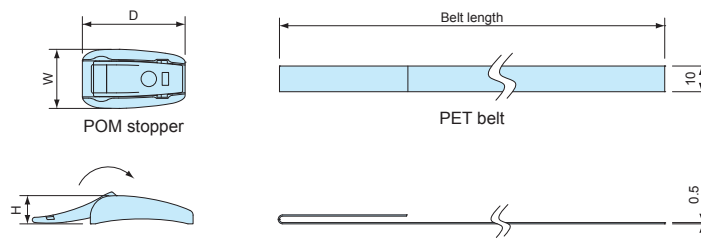

**PKB-10S**

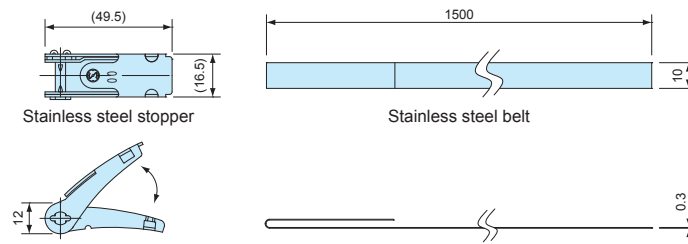

**PKB-20S**

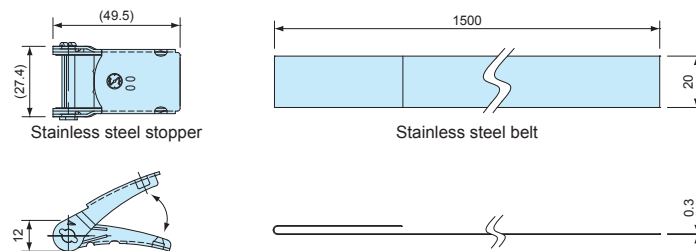

**Components**

Part name	Pcs	Material	Color / Finish
Stopper	2	POM • Stainless steel SUS304	Black • Barrel finish
Belt	2	PET • Stainless steel SUS430	Gray • Bright Annealed finish

**Product no. / Dimensions**

Product no.	W	D	H	Belt material	Belt length	Tensile strength (horizontal)	Weight (g)	Pack of
<b>NEW</b> PKB-10PM	24	23	11	PET	500mm	0.8kN	14	2
PKB-10P	23	40	11	PET	1,500mm	1.3kN	31.8	2
PKB-10S	—	—	—	Stainless steel	1,500mm	1.4kN	101.6	2
PKB-20S	—	—	—	Stainless steel	1,500mm	2.9kN	182.2	2

**PFRF SERIES**

**RUBBER FEET**

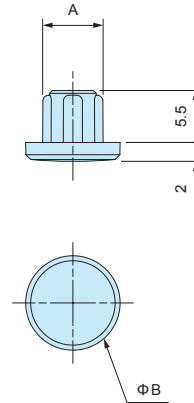

- Recommended to be used with WP series as a desktop-type unit.
- No additional hole milling required as the rubber feet fits snugly into the screw holes.
- Made from elastomer material.
- Unavailable for use with WP5-7-2, 5-7-3, 6-8-2, and 6-8-3 models.

**Product no. / Dimensions**

■ UL94HB

Product no.	Dimensions		Material	Color	Suitable enclosures	Pack of
	A	B				
PFRF-M2.5D	6.4	10	Elastomer UL94HB	Dark gray	WP models: 8-8-2 • 8-8-4 • 8-10-2 • 8-10-4 • 9-13-3 • 9-13-4 • 10-10-3 • 10-10-4 • 11-15-3 • 11-15-4 • 13-18-3 • 13-18-5	4
PFRF-M3D	7.2	11	Elastomer UL94HB	Dark gray	WP models: 15-15-4 • 15-15-6 • 15-21-4 • 15-21-6 • 20-20-5 • 20-20-7 • 20-28-5 • 20-28-7	4

**MR SERIES**

**TORX SCREW for WP**

**NEW SIZE**



Head type (with pin)



- Recommended to be used for tamper resistance, or for an elegant look and feel.
- Requires the use of a specialized screwdriver.
- Unavailable for use with WP5-7-2, 5-7-3, 6-8-2, and 6-8-3 models.

**Product no. / Dimensions**

Product no.	Dimensions		TORX head no.	Material	Finish	Suitable enclosures	Pack of
	M	L					
MR2.5-8ST	2.5	8	T 8 (with pin)	Stainless steel	Unfinished	WP8-8-2 • 8-10-2 • 9-13-3 • 10-10-3 • 11-15-3 • 13-18-3 / WSC series	20
MR2.5-16ST	2.5	16	T 8 (with pin)	Stainless steel	Unfinished	WP8-8-4 • 8-10-4 • 9-13-4 • 10-10-4 • 11-15-4 • 13-18-5	20
<b>NEW</b> MR3-8ST	3	8	T10 (with pin)	Stainless steel	Unfinished	WP15-15-4 • 15-15-6 • 15-21-4 • 15-21-6 • 20-20-5 • 20-20-7 • 20-28-5 • 20-28-7	20

EM SERIES

PCB MOUNTING SCREW

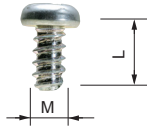

- Self-tapping screws for mounting PCB on bosses or standoffs.
- EM-3-6 self-tapping screws are suitable for mounting 1.6mm or thicker PCB.

Product no. / Dimensions

Product no.	M	L	Material	Finish	Suitable enclosures	Pack of
EM-1.6	1.6	4	Steel	Trivalent chromate	WC • CSS • CS • PS (M1.6 size)	50
EM-2	2	5	Steel	Trivalent chromate	PS • TW • TWN • TWF • WP (M2 size)	50
EM-2.3	2.3	6	Steel	Trivalent chromate	WH • LC • LCT • LCS • LCE • PFE WSC (Top cover bosses) PF • PFF (M2.3 size) TW • TWN • TWF (M2.3 size) WP (M2.3 size)	50
<b>NEW</b> EM-2.3-8	2.3	8	Steel	Trivalent chromate	WSC (Bottom base bosses)	50
EM-2.6	2.6	6	Steel	Trivalent chromate	PF • PFF • WP (M2.6 size)	50
EM-3	3	5	Steel	Trivalent chromate	SU TWS • TW • TWN • TWF (M3 sizes)	50
EM-3-6	3	6	Steel	Trivalent chromate		50

MR SERIES

TORX SCREW



Countersunk head

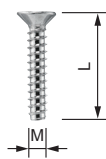

Pan head

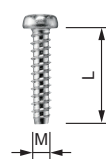

With pin



★ Without pin



★ : MR1.6-6S, MR-2S, MR2.6-10□, and MR3-14□ are without pin.

Product no. / Dimensions

★Mark = Without pin

Product no.	M	L	head no.	Head style	Material	Finish	Suitable enclosures	Pack of
MR1.6-6S★	1.6	6	T3	Pan	Steel	Nickel plated	CS • CSS	20
MR2.5-8PS	2.5	8	T8	Pan	Steel	Nickel plated	PF • PFE • PFF (M2.5 size)	20
MR2.6-10S★	2.6	10	T8	Countersunk	Steel	Nickel plated	TW • TWN (M2.6 models) TWF (M2.6 models)	20
MR2.6-10B★	2.6	10	T8	Countersunk	Steel	Black trivalent chromate	MX • MXA • MXB • MXF (M2.6 models)	20
MR2.6-12PS	2.6	12	T8	Pan	Steel	Nickel plated	LCT • LCS • LC115-F2 / F3 LCT • LCS • LC145S-F6	20
MR2.6-14PS	2.6	14	T8	Pan	Steel	Nickel plated	LCT • LCS • LC115H-F2 / F3 / M2 / 9V LCT • LCS • LC135-F4 / M2 / M3 / 9V LCT • LCS • LC135H-F4 / M2 / M3 / 9V LCT • LCS • LC145-F6 / M2 / M4 LCT • LCS • LC145H-F6 / M2 / M4 LCT • LCS • LC165-M4 LCT • LCS • LC165H-M4	20
MR2.6-14S	2.6	14	T8	Countersunk	Steel	Nickel plated	LCT • LCS • LC115-N / F2 / F3 LCT • LCS • LC145S-F6 / 145S-N LCE115-N TW • TWN7-2-11 / 7-4-11 / 7-5-11 TWF7-2-11 / 7-4-11 / 7-5-11 / 8-2-8 / 8-4-8	20
MR2.6-18S	2.6	18	T8	Countersunk	Steel	Nickel plated	LCT • LCS • LC115H-N / F2 / F3 / M2 / 9V LCT • LCS • LC135-N / F4 / M2 / M3 / 9V LCT • LCS • LC135H-N / F4 / M2 / M3 / 9V LCT • LCS • LC145-N / F6 / M2 / M4 LCT • LCS • LC145H-N / F6 / M2 / M4 LCT • LCS • LC165-N / M4 LCT • LCS • LC165H-N / M4 LCE115H-N • LCE135-N • LCE145H-N • LCE165H-N	20
MR3-8PS	3	8	T10	Pan	Steel	Nickel plated	PF • PFE • PFF (M3 size)	20
MR3-14S★	3	14	T10	Countersunk	Steel	Nickel plated	TW • TWN (M3 models)	20
MR3-14B★	3	14	T10	Countersunk	Steel	Black trivalent chromate	TWF (M3 models) MX • MXA • MXB • MXF (M3 models)	20
MR-1S	3	5	T10	Countersunk	Steel	Nickel plated	UC	20
MR-1B	3	5	T10	Countersunk	Steel	Black trivalent chromate	UC • UCY • US	20
MR-2S	3	10	T10	Countersunk	Steel	Nickel plated	HEN	20

# PMF-6B

# SMALL PROTECTIVE VENT

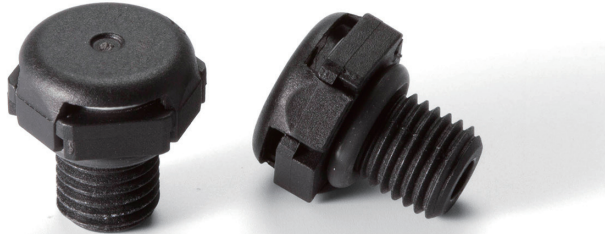

Application example

- Small and screw-in protective vent suitable for compact, and hand-held type devices.
- IP68 protection class (water depth 2 meters / 60 mins) and -40°C ~ +150°C operating temperature range allows it to be used in various environments.
- Suitable for enclosures with capacities of 2.0 litres or under.
- For outdoor use, installation on the side of the enclosure unit is recommended.

## PMF-6B dimensions

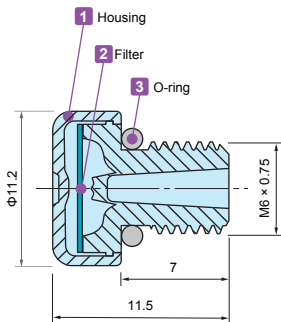

## Hole milling drawings

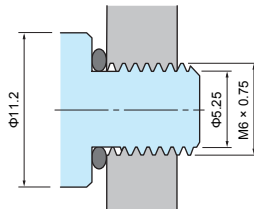

## Installation drawings

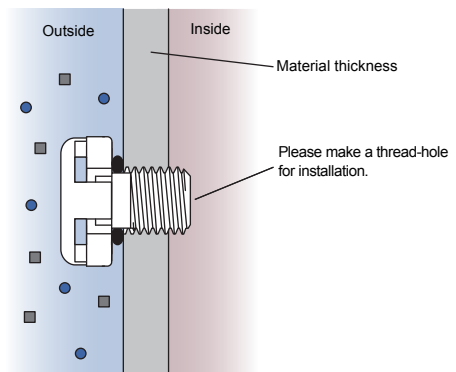

### Technical Data

Airflow	300ml / min (dp = 7 kPa)
Recommended Torque	0.2 ~ 0.4 N • m
Certifications	IEC60529 (Protection class test) : IP66 • IP67 • IP68 IEC60068-2-1, 2, 14 (Heat resistance test) : -40°C ~ +150°C IEC60068-2-78 (Humidity test) : 85°C • 85% humidity • 1000 hours IEC60068-2-64 (Vibration test) UL94V-0 (Flame-resistant) • UL746C f1

### Product no. / Dimensions

Product no.	Material			G	
● Black	1 Housing	2 Filter	3 O-ring	Thread size	Mount hole
PMF-6B	PA6 (Body) • PA66 (Cap)	PTFE	Silicone	M6 x 0.75	—

PMF-12M

STAINLESS STEEL PROTECTIVE VENT

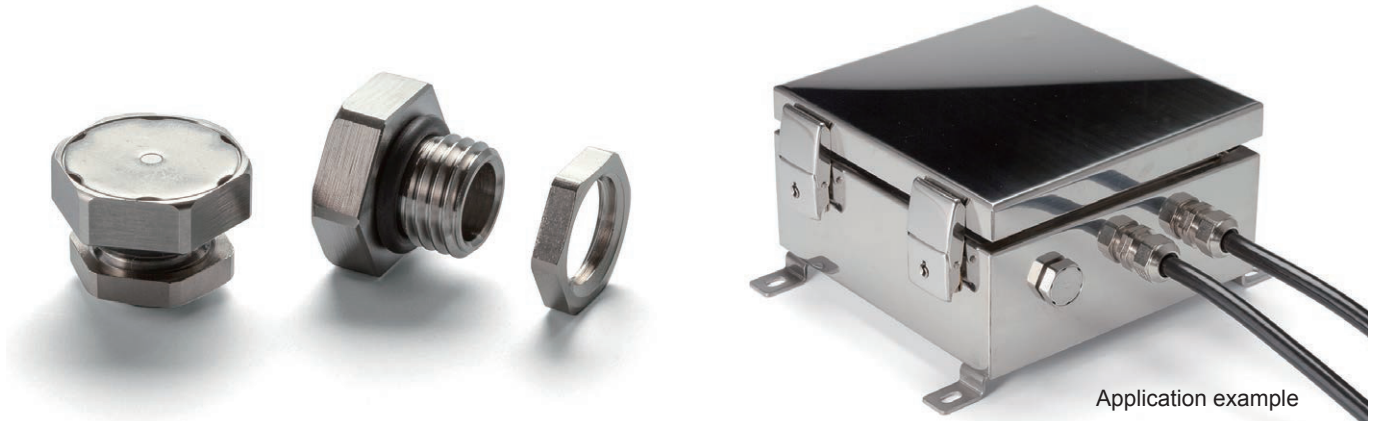

Application example

- Stainless steel protective vent for superior durability and chemical resistance.
- IP68 protection class (water depth 2 meters / 60 mins) and -40°C ~ +125°C operating temperature range allows it to be used in various environments.
- Suitable for enclosures with capacities of 20 liters or under.
- For outdoor use, installation on the side of the enclosure unit is recommended.

PMF-12M dimensions

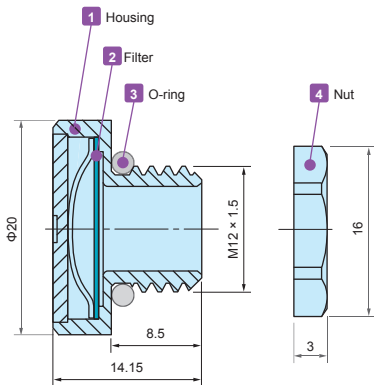

Hole milling drawings

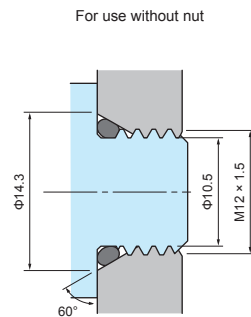

■ While Φ12.2mm through-hole is sufficient for installation, 60° angle tapered hole is recommended to prevent deformation of the O-ring.

Installation drawings

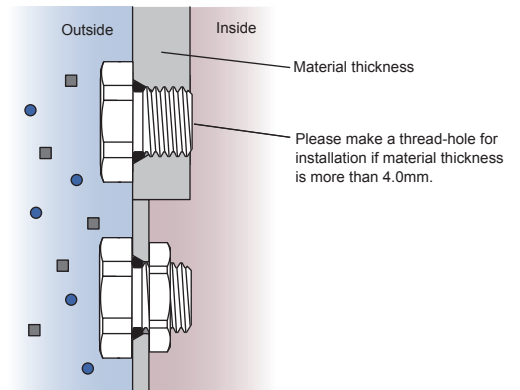

■ If used with a lock nut, material thickness should not exceed 4.0mm.

Technical Data

Airflow	1600ml / min (dp = 7 kPa)
Recommended Torque	0.6 ~ 1.2 N · m
Certifications	IEC60529 (Protection class test) : IP66 • IP67 • IP68 • IP69K IEC60068-2-1, 2, 14 (Heat resistance test) : -40°C ~ +125°C IEC60068-2-78 (Humidity test) : 85°C • 85% humidity • 1000 hours IEC60068-2-64 (Vibration test)

Product no. / Dimensions

Product no.	Material				G		Nut SW
	1 Housing	2 Filter	3 O-ring	4 Nut	Thread size	Mount hole	
PMF-12M	Stainless steel	PTFE	Silicone	Brass • Nickel plated	M12 x 1.5	Φ12.2	15

PMF SERIES

PROTECTIVE VENT



Application example

- Protective vents prevents the ingress of a variety of contaminants, such as water, dust and other particules while allowing water vapor molecules to diffuse through the microporous membrane.
- Equalize pressure and reduce condensation by allowing airflow into and out of sealed enclosures.
- With an IP68 protection class (water depth 2 meters / 60 mins) and -40°C ~ +125°C operating temperature range, it can be used in harsh environmental conditions.
- PMF-6B works up to 2 liters capacity enclosures. Whereas, PMF-12 models work for up to 5 liters and PMF-12HS models work for up to 50 liters.
- For outdoor use, more efficient to install on the side(s).
- Recommended to use for industrial, electric, electronics purpose only.

PMF dimensions

■ Drawings below are reference examples only.  
DXF/DWG/PDF drawings available on our website.

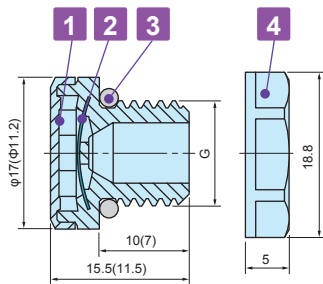

( ) values are for PMF-6B.  
Lock nut is not available for PMF-6B.

Hole milling drawings

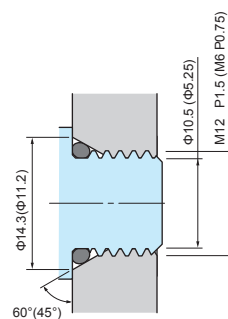

■ While  $\Phi 12.2\text{mm}$  through-hole is sufficient for installation,  $60^\circ$  angle tapered hole is recommended to prevent deformation of the O-ring.

Installation drawings

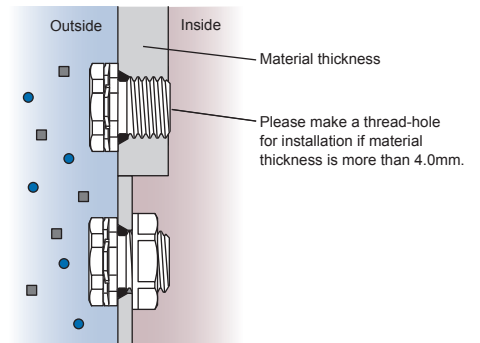

■ If used with a lock nut, material thickness should not exceed 4.0mm, and  $\Phi 12.2\text{mm}$  through-hole is sufficient.

Technical Data

Product no.	PMF-6B	PMF-12	PMF-12HA
Airflow	300ml / min (dp = 7 kPa)	450ml / min (dp = 7 kPa)	4000ml / min (dp = 7 kPa)
Recommended Torque	0.2 ~ 0.4 N · m	0.6 ~ 0.8 N · m	0.6 ~ 0.8 N · m
Certifications	IEC60529 (Protection class test): IP66 • IP67 • IP68 • IP69K (Not for PMF-6B) IEC60068-2-1, 2, 14 (Heat resistance test): - 40°C ~ +125°C (~+150°C for PMF-6B) IEC60068-2-78 (Humidity test): 85°C • 85% humidity • 1000 hours IEC60068-2-64 (Vibration test) (PMF-6B only) UL94V-0 (Flame-resistant) • UL746C f1		

Product no. / Dimensions

Product no.		Material				G		Nut SW
● Light gray	● Black	1 Housing	2 Filter	3 O-ring	4 Lock nut	Thread size	Mount hole	
—	<b>NEW</b> PMF-6B	PA6 (Body) PA66 (Cap)	PTFE	Silicone	n/a	M6 x 0.75	—	—
PMF-12S	PMF-12B	PA6	PTFE	Silicone	PA6 (UL94V-2)	M12 x 1.5	$\Phi 12.2$	17
PMF-12HAS	PMF-12HAB	PA6	PTFE	Silicone	PA6 (UL94V-2)	M12 x 1.5	$\Phi 12.2$	17



# Effect of PMF Series Protective Vent on WP series Box

WP series enclosure comes with a silicone gasket, which allows the enclosure to be extremely airtight when assembled. When facing with high temperature fluctuations over a period of time, the pressure within the enclosure will increase accordingly. If this air pressure within is unable to be properly vented, it may cause the enclosure to deform, such as expanding past its normal size. By installing the PMF series protective vent, it will assist in equalizing the air pressure, and prevent potential deformation.

**[Evaluation Target]** 1. WP20-28-7G                      2. WP20-28-7G - PMF-12HAG Installed on 1 side

**[Test Conditions]**    Heat Cycle Test

Device :    Constant temperature/humidity test chamber - LH43-W14P  
 Make :     NAGANO SCIENCE CO., LTD.

Heat cycle testing in -10°C ~ +60°C (Operating temperature for WP enclosures)  
 1 cycle :    -10°C 3 hours / 60°C 3 hours  
 Tested 5 cycles.

**Test Result : 1. WP20-28-7G :**

Increased air pressure within the enclosure and unable to be balanced/vented (deformation).

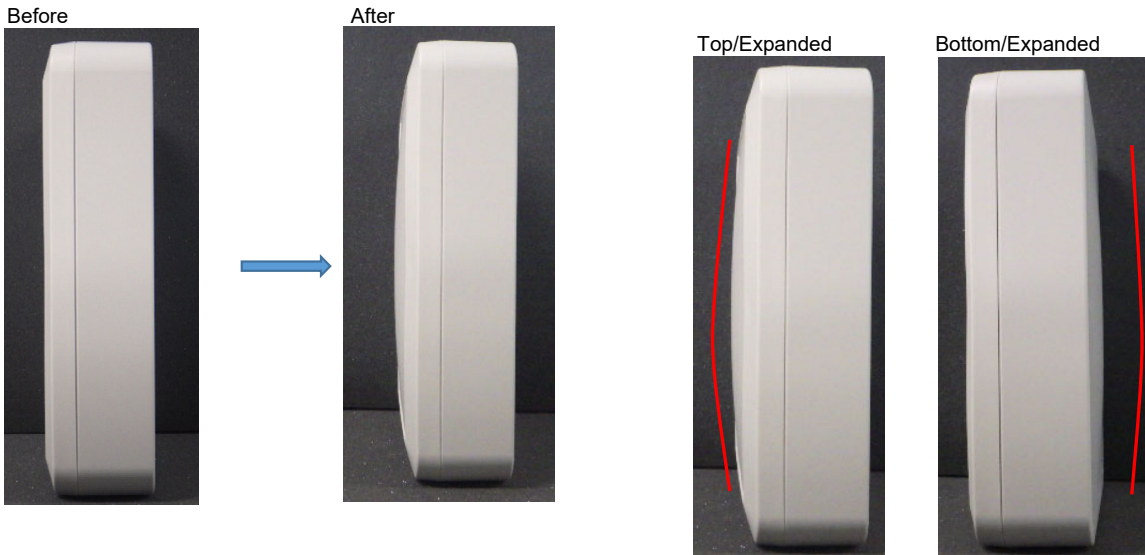

**Test Result : 2. WP20-28-7G - PMF-12HAG Installed on 1 side**

Air pressure within the enclosure balanced/vented through the protective vent (no deformation).

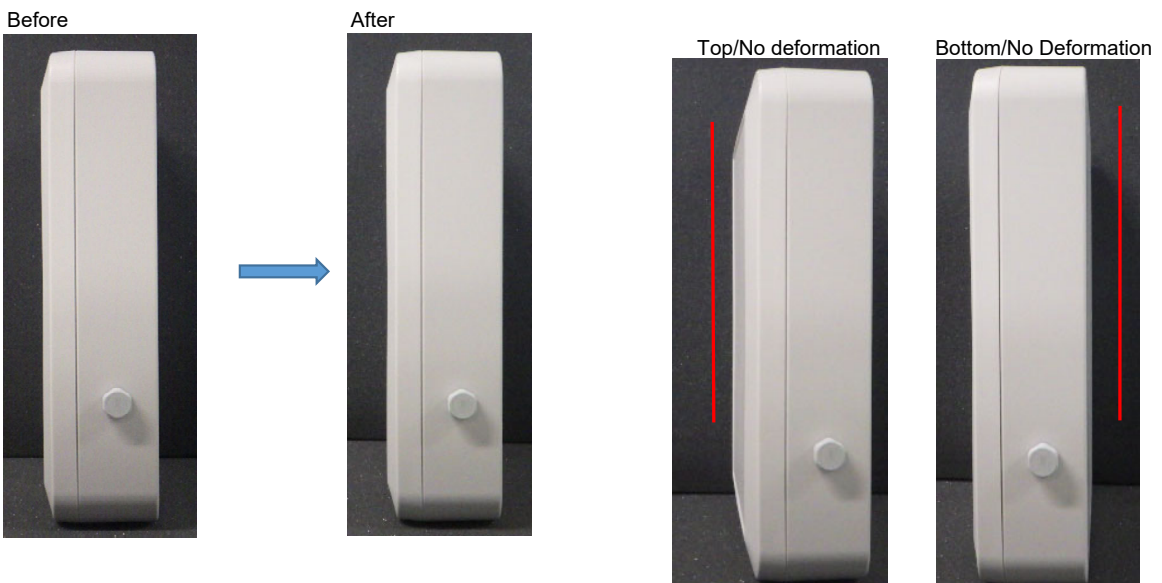



- Weatherproof cable gland equipped with high ultraviolet and degradation resistant silicone sealing insert and O-ring.
- Recommended to use outdoors where waterproofing is critical.

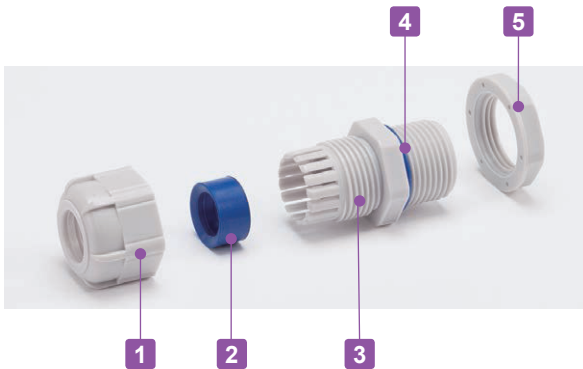

Components

■ PA = Polyamide

No.	Part name	Material
1	Cap	PA66 UL94V-2
2	Sealing insert	Silicone
3	Connector	PA66 UL94V-2
4	O-ring	Silicone
5	Nut	PA66 UL94V-2

RMW dimensions

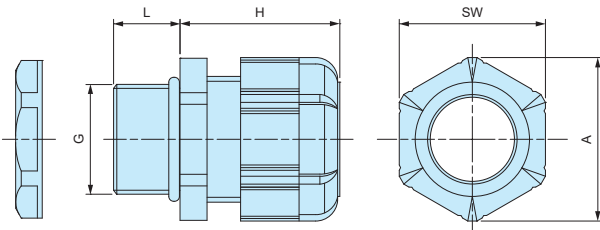

Technical Data

Protection class: IP67  
Operating temperature: -20°C ~ +80°C

- DXF/DWG/PDF drawings available on our website.
- Lock nut is not included for RMW10S-6.  
Please drill a proper thread hole into the enclosure for installation.

Product no. / Dimensions

Product no.		G		Cable range		L	H Max	SW	A	Pack of
● Black	● Light gray	Thread size	Mounting hole	Min	Max					
RMW8L-2.5B	RMW8L-2.5S	M8×1.25	Φ8.2	1	2.5	13	19.5	11.8	13.5	1
RMW8L-4B	RMW8L-4S	M8×1.25	Φ8.2	2.5	4	13	19.5	11.8	13.5	1
RMW10S-6B	RMW10S-6S	M10×1.5	—	3	6	8	20.5	13	14.4	1
RMW10L-6B	RMW10L-6S	M10×1.5	Φ10.2	3	6	13	20.5	13	14.4	1
RMW12S-7B	RMW12S-7S	M12×1.5	Φ12.2	3.5	7	9	20.5	16	17.6	1
RMW12L-7B	RMW12L-7S	M12×1.5	Φ12.2	3.5	7	14.5	20.5	16	17.7	1
RMW16S-8B	RMW16S-8S	M16×1.5	Φ16.2	4	8	9	23.5	19	21	1
RMW16L-8B	RMW16L-8S	M16×1.5	Φ16.2	4	8	15	24	19	21	1
RMW20S-12B	RMW20S-12S	M20×1.5	Φ20.2	6	12	10	29	24	26.2	1
RMW20L-12B	RMW20L-12S	M20×1.5	Φ20.2	6	12	15	28.5	24	26.2	1
RMW25L-17B	RMW25L-17S	M25×1.5	Φ25.2	11	17	15	35	33	36.2	1
RMW32L-21B	RMW32L-21S	M32×1.5	Φ32.3	13	21	15	38	36	39.5	1
RMW40L-27B	RMW40L-27S	M40×1.5	Φ40.3	18	27	18	43.5	45.7	50.5	1
RMW50L-38B	RMW50L-38S	M50×1.5	Φ50.4	27	38	20	50.5	60	66.5	1
RMW8L-2.5B-P	RMW8L-2.5S-P	M8×1.25	Φ 8.2	1	2.5	13	19.5	11.8	13.5	100
RMW8L-4B-P	RMW8L-4S-P	M8×1.25	Φ 8.2	2.5	4	13	19.5	11.8	13.5	100
RMW10L-6B-P	RMW10L-6S-P	M10×1.5	Φ10.2	3	6	13	20.5	13	14.4	100
RMW12S-7B-P	RMW12S-7S-P	M12×1.5	Φ12.2	3.5	7	9	20.5	16	17.6	100
RMW12L-7B-P	RMW12L-7S-P	M12×1.5	Φ12.2	3.5	7	14.5	20.5	16	17.7	100
RMW16S-8B-P	RMW16S-8S-P	M16×1.5	Φ16.2	4	8	9	23.5	19	21	100
RMW16L-8B-P	RMW16L-8S-P	M16×1.5	Φ16.2	4	8	15	24	19	21	100
RMW20S-12B-P	RMW20S-12S-P	M20×1.5	Φ20.2	6	12	10	29	24	26.2	100
RMW20L-12B-P	RMW20L-12S-P	M20×1.5	Φ20.2	6	12	15	28.5	24	26.2	100
RMW25L-17B-P	RMW25L-17S-P	M25×1.5	Φ25.2	11	17	15	35	33	36.2	100

# RMW series silicone sealing insert weatherproof test report

Object: Cut into a piece of the silicone sealing insert from RMW series and attach it onto an aluminium plate.  
 For comparison, NBR sealing insert from our RM and EPDM sealing insert from another manufacturer is also attached for comparison purposes.

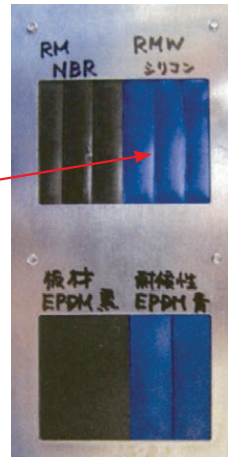
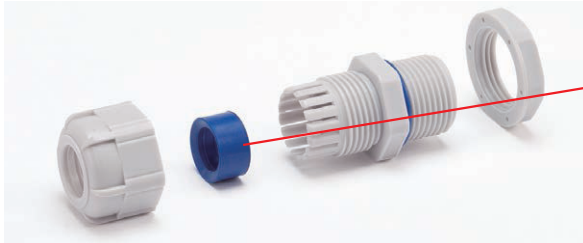

Before



After

**Testing conditions**

**Equipment :** 7.5kW Super Xenon Weather Meter SX75 (Suga Test Instruments Co., Ltd.- <http://www.sugatest.co.jp/english/>)  
**Conditions :** JIS B7754 : 1991

Testing with an authorized Xenon arc lamp weathering test equipment under the conditions denoted below.

Irradiance : 180W/m<sup>2</sup> at 300-400nm

Black Panel Temperature : 63±3°C Humidity Range : 50±10%

Cycle Conditions : 120 minutes cycle (18 minutes irradiation + water spray - 102 minutes irradiation)

2,000 hours (equivalent to a period of 4 years under natural conditions)

**Time period :**

**Total radiant exposure :** 1296MJ/m<sup>2</sup>

**Test result (visual / touch inspection)**

**Silicone sealing insert material :** No cracks, no gloss transition, no powder - no appearance change at all. Flexibility remains unchanged.

Before



After



**NBR material from our RM series :** Lost glossiness on the surface and material is stiffened.

Before



After



**EPDM material from weatherproof cable gland of another manufacturer :** Cracked, color drastically faded and powder appeared on the surface.

Before

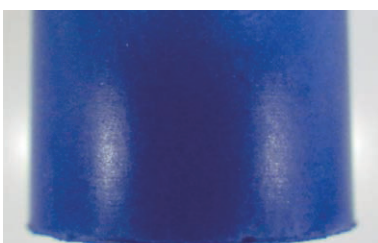

After

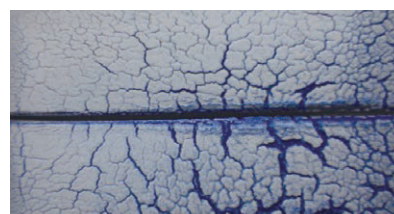

# RM SERIES

# POLYAMIDE CABLE GLAND

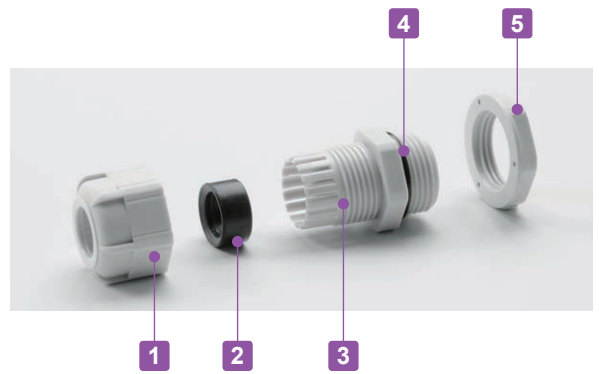

- Low cost cable glands made from polyamide material.
- Wide selection, for M8 ~ M63, suitable for  $\Phi 1\text{mm} \sim \Phi 44\text{ mm}$  cable.
- High oil resistant NBR rubber sealing and O-ring.
- IP67 protection class.

### Components

■ PA = Polyamide

No.	Part name	Material
1	Cap	PA66 UL94V-2
2	Sealing insert	NBR
3	Connector	PA66 UL94V-2
4	O-ring	NBR
5	Lock nut	PA66 UL94V-2

### RM dimensions

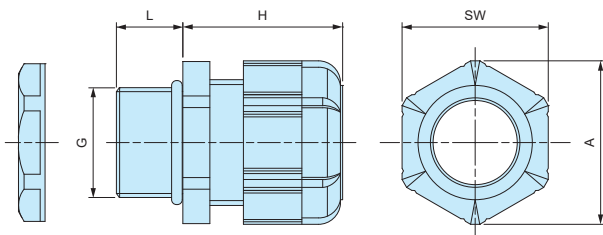

### Technical Data

Protection class: IP67  
Operating temperature: -20°C ~ +80°C

- DXF/DWG/PDF drawings available on our website.
- Lock nut is not included for RM8S-2.5, 8S-4, and 10S-6 models.  
Please drill a proper thread hole into the enclosure for installation.

### Product no. / Dimensions

Product no.		G		Cable range		L	H Max	SW	A	Pack of
● Black	● Light gray	Thread size	Mounting hole	Min	Max					
RM8S-2.5B	RM8S-2.5S	M8×1.25	—	1	2.5	7.5	19.5	11.8	13.5	1
RM8L-2.5B	RM8L-2.5S	M8×1.25	Φ8.2	1	2.5	13	19.5	11.8	13.5	1
RM8S-4B	RM8S-4S	M8×1.25	—	2.5	4	7.5	19.5	11.8	13.5	1
RM8L-4B	RM8L-4S	M8×1.25	Φ8.2	2.5	4	13	19.5	11.8	13.5	1
RM10S-6B	RM10S-6S	M10×1.5	—	3	6	8	20.5	13	14.4	1
RM10L-6B	RM10L-6S	M10×1.5	Φ10.2	3	6	13	20.5	13	14.4	1
RM12S-7B	RM12S-7S	M12×1.5	Φ12.2	3.5	7	9	20.5	16	17.6	1
RM12L-7B	RM12L-7S	M12×1.5	Φ12.2	3.5	7	14.5	20.5	16	17.7	1
RM16S-8B	RM16S-8S	M16×1.5	Φ16.2	4	8	9	23.5	19	21	1
RM16L-8B	RM16L-8S	M16×1.5	Φ16.2	4	8	15	24	19	21	1
RM20S-12B	RM20S-12S	M20×1.5	Φ20.2	6	12	10	29	24	26.2	1
RM20L-12B	RM20L-12S	M20×1.5	Φ20.2	6	12	15	28.5	24	26.2	1
RM25L-17B	RM25L-17S	M25×1.5	Φ25.2	11	17	15	35	33	36.2	1
RM32L-21B	RM32L-21S	M32×1.5	Φ32.3	13	21	15	38	36	39.5	1
RM40L-27B	RM40L-27S	M40×1.5	Φ40.3	18	27	18	43.5	45.7	50.5	1
RM50L-38B	RM50L-38S	M50×1.5	Φ50.4	27	38	20	50.5	60	66.5	1
RM63L-44B	RM63L-44S	M63×1.5	Φ63.4	37	44	20	53	68	75.5	1
RM8L-2.5B-P	RM8L-2.5S-P	M8×1.25	Φ8.2	1	2.5	13	19.5	11.8	13.5	100
RM8L-4B-P	RM8L-4S-P	M8×1.25	Φ8.2	2.5	4	13	19.5	11.8	13.5	100
RM10L-6B-P	RM10L-6S-P	M10×1.5	Φ10.2	3	6	13	20.5	13	14.4	100
RM12S-7B-P	RM12S-7S-P	M12×1.5	Φ12.2	3.5	7	9	20.5	16	17.6	100
RM12L-7B-P	RM12L-7S-P	M12×1.5	Φ12.2	3.5	7	14.5	20.5	16	17.7	100
RM16S-8B-P	RM16S-8S-P	M16×1.5	Φ16.2	4	8	9	23.5	19	21	100
RM16L-8B-P	RM16L-8S-P	M16×1.5	Φ16.2	4	8	15	24	19	21	100
RM20S-12B-P	RM20S-12S-P	M20×1.5	Φ20.2	6	12	10	29	24	26.2	100
RM20L-12B-P	RM20L-12S-P	M20×1.5	Φ20.2	6	12	15	28.5	24	26.2	100
RM25L-17B-P	RM25L-17S-P	M25×1.5	Φ25.2	11	17	15	35	33	36.2	100

# RPG SERIES

# POLYAMIDE CABLE GLAND



IP67

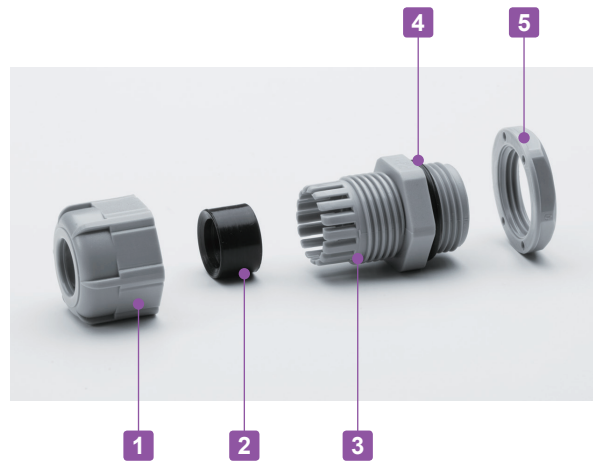

- Inexpensive cable glands made from polyamide material with PG threading.
- High oil resistant NBR rubber sealing and O-ring.
- IP67 protection class.

## RPG dimensions

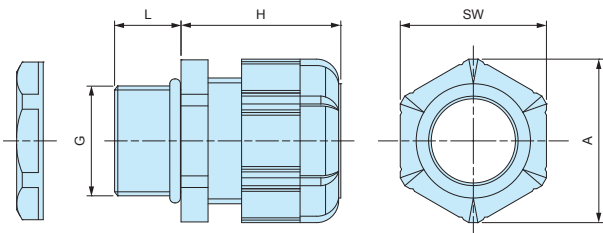

■ DXF/DWG/PDF drawings available on our website.

### Components

■ PA = Polyamide

No.	Part name	Material
1	Cap	PA66 UL94V-2
2	Sealing insert	NBR
3	Connector	PA66 UL94V-2
4	O-Ring	NBR
5	Lock-nut	PA66 UL94V-2

### Technical Data

Protection class: IP67  
Operating temperature: -20°C ~ +80°C

### Product no. / Dimensions

Product no.		G			Cable range		L	H Max	SW	A	Pack of
● Black	● Gray	Thread size	Thread dia.	Mounting hole	Min	Max					
RPG7-7B	RPG7-7G	PG7	12.5	Φ12.7	3	7	9	20.5	16	17.7	1
RPG9-8B	RPG9-8G	PG9	15.2	Φ15.4	4	8	9	23.5	19	21	1
RPG11-10B	RPG11-10G	PG11	18.6	Φ18.8	5	10	9	26	22	24	1
RPG13.5-11B	RPG13.5-11G	PG13.5	20.4	Φ20.6	6	11	10	29	24	26.4	1
RPG16-14B	RPG16-14G	PG16	22.5	Φ22.7	8	14	10	30	26.7	29.5	1
RPG21-18B	RPG21-18G	PG21	28.3	Φ28.5	13	18	12	35	33	36.5	1
RPG29-25B	RPG29-25G	PG29	37	Φ37.2	18	25	12	41.5	42	46.5	1

**SP SERIES**

**SEALING PLUG**



**SP dimensions**

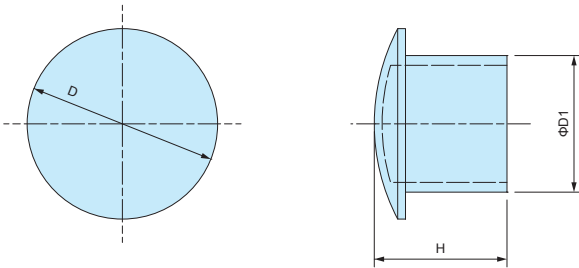

■ Material : Nylon

- Sealing plug for cable glands when not in use.
- Maintain a waterproof seal when plugged into the sealing insert on cable glands.

**Product no. / Dimensions**

Product no.	D	D1	H	Suitable cable glands	Pack of
SP-12	10.2	6	15.5	RMW12, RM12, RMW16, RM16, RPG7, RPG9	10
SP-16	15.6	9.5	15.5	RMW20, RM20, RPG11, RPG13.5	10
SP-20	19.6	13.5	16.5	RPG16	10
SP-25	24.4	17.5	17	RMW25, RM25, RMW32, RM32, RPG21	5
SP-40	32.5	24.5	17.5	RMW40, RM40, RPG29	5
SP-50	47.2	38.9	17.6	RMW50, RM50	5



- High water protection IP68 (1bar / 30min) polyamide cable gland.
- Wide selection, for M8 ~ M50, suitable for  $\Phi 2.5\text{mm} \sim \Phi 42\text{mm}$  cable.
- Super tough and superior heat resistant PA6GF (glass fiber filled PA6) material on cap and connector.
- Safer halogen free, eco-friendly product.

Technical Data
Protection class: IP68 1bar / 30min
Operating temperature: -20°C ~ +100°C
Compliant with EN50262 Ver. A

**AG Series**

Thicker sealing insert evenly hold a cable by having a larger holding area.  
Remains durable even after repeated tightening / loosening.

**Lamellar insert type**

If over-tightened, it can cause the rubber bush or cable to deform, which can allow water to seep in.

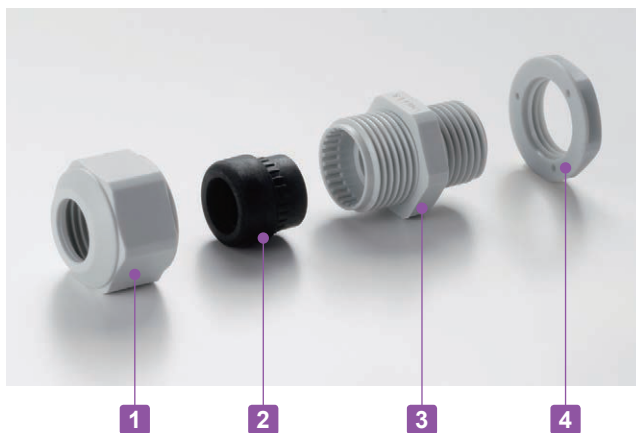
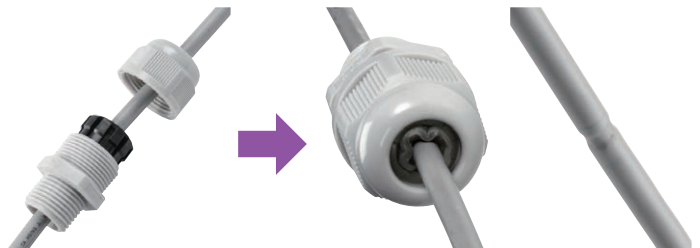
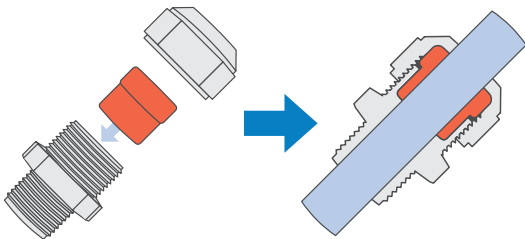

**Components**

■ PA6GF = Polyamide6 Glass Fiber Filled

No.	Part name	Material
1	Cap	PA6GF
2	Sealing insert	TPE
3	Connector	PA6GF
4	Lock nut	PA6

■ Lock nut is not included for M8 and M10 sizes.  
Please drill a proper thread hole into the enclosure for installation.

- Proper tightening torque varies by each cable diameter. Tighten the cap until top of the sealing insert forms a small bead between the cap and the cable.



■ No optional sealing washer is required when installing on an even surface because of the built-in waterproof rib.

■ An optional sealing washer is required when installing on an uneven surface. (See page AGP-1 for more information on the optional sealing washer)

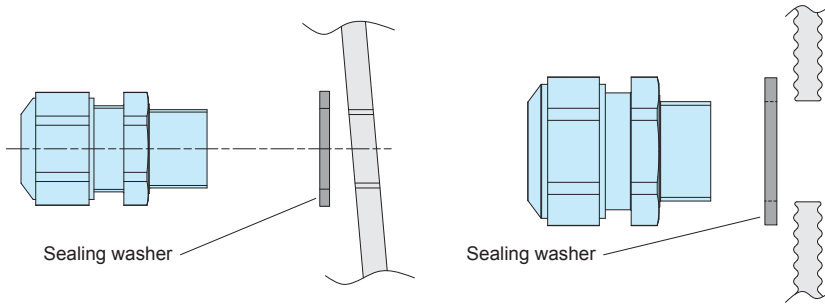

**AG dimensions**

■ DXF/DWG/PDF drawings available on our website.

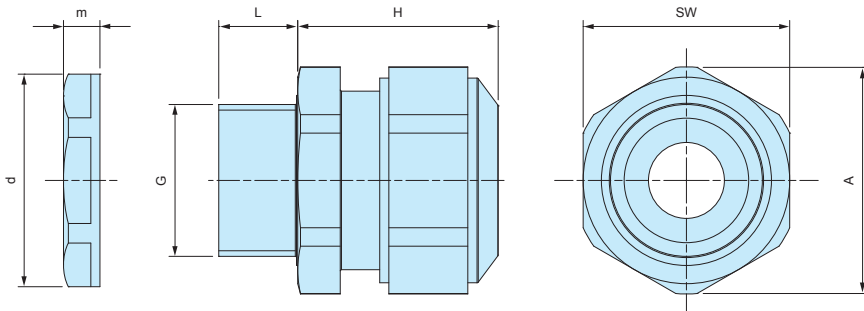

■ Lock nut is not included for M8 and M10 sizes. Please drill a proper thread hole into the enclosure for installation.

**Product no. / Dimensions**

Product no.		G		Cable range		L	H Max	SW	A	d	m	Pack of
● Black	● Light gray	Thread size	Mounting hole	Min	Max							
AG8-3.5B	AG8-3.5S	M8×1.0	—	2.5	3.5	10	17	12	13.2	—	—	1
AG8-5B	AG8-5S	M8×1.0	—	3.5	4.7	10	17	12	13.2	—	—	1
AG10-6B	AG10-6S	M10×1.0	—	4	6	10	19	15	16.5	—	—	1
AG12-5B	AG12-5S	M12×1.5	Φ12.2	3.5	4.7	12	23.5	17	18.7	18.8	5	1
AG12-6.5B	AG12-6.5S	M12×1.5	Φ12.2	5	6.5	12	23	17	18.7	18.8	5	1
AG12-8B	AG12-8S	M12×1.5	Φ12.2	6.5	7.8	12	23	17	18.7	18.8	5	1
AG16-10B	AG16-10S	M16×1.5	Φ16.2	8	10	12	26	21	23.1	24.3	5	1
AG20-15B	AG20-15S	M20×1.5	Φ20.2	11	15	13	27	27	29.7	29	6	1
AG25-16B	AG25-16S	M25×1.5	Φ25.2	12.5	16	13	34	34	37.4	36	6.7	1
AG25-20B	AG25-20S	M25×1.5	Φ25.2	16	20	13	34	34	37.4	36	6.7	1
AG32-25.5B	AG32-25.5S	M32×1.5	Φ32.3	21	25.5	15	36	41	45.6	46	8	1
AG40-28.5B	AG40-28.5S	M40×1.5	Φ40.3	24	28.5	15	41	50	55.4	53.5	9	1
AG40-33B	AG40-33S	M40×1.5	Φ40.3	28.5	33	15	41	50	55.4	53.5	9	1
AG50-37B	AG50-37S	M50×1.5	Φ50.4	33	37	16	45	60	65.5	66	9.6	1
AG50-42B	AG50-42S	M50×1.5	Φ50.4	37	42	16	45	60	65.5	66	9.6	1



# AGP SERIES

# SEALING WASHER for AG • AGSP

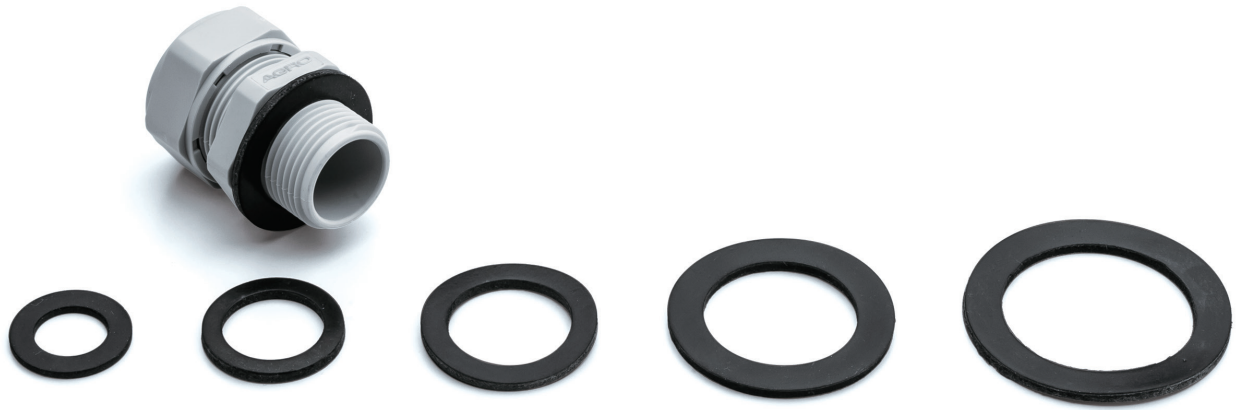

- Sealing washer for AG series.
- Made from oil resistant NBR material.
- Use in the case of installation on a rough or uneven surfaces.
- Selectable in 7 sizes (from M12 to M50)
- Sealing washer is not necessary for installation on flat surfaces.

## AGP Dimensions

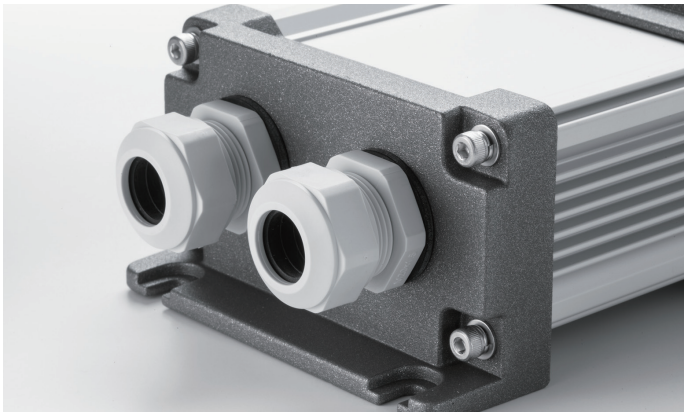
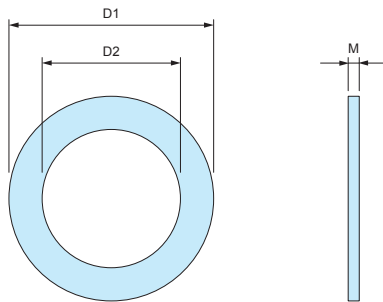

- Material : NBR

### Product no. / Dimensions

Product no.	D1	D2	M	Suitable cable gland	Pack of
AGP-12	20	12	1.6	AG12	10
AGP-16	23.5	16.5	2.0	AG16	10
AGP-20	29	20	2.0	AG20	10
AGP-25	37	25	2.0	AG25	10
AGP-32	44	32	2.2	AG32	5
AGP-40	52	40	2.2	AG40	5
AGP-50	64	50	3.1	AG50	5

# RSP SERIES

# STRAIN RELIEF CABLE GLAND



■ DXF/DWG/PDF drawings available on our website.

## RSP dimensions

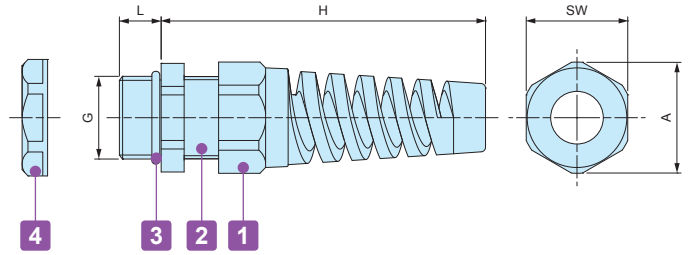

## Components

■ PA = Polyamide

No.	Part name	Material
1	Strain relief cap	PA66 (UL94V-2)
-	Sealing insert	NBR
2	Connector	PA66 (UL94V-2)
3	O-ring	NBR
4	Lock- nut	PA66 (UL94V-2)

Technical Data
Protection class : IP67 Temperature range -20°C ~ +80°C

## Product no. / Dimensions

Product no.		G		Cable range		L	H Max	SW	A	Pack of
● Black	● Light gray	Thread size	Mounting hole	Min	Max					
RSP12-6B	RSP12-6S	M12×1.5	φ12.2	3.5	6	9	62	16	17	1
RSP16-8B	RSP16-8S	M16×1.5	φ16.2	4	8	9	69	19.5	21	1
RSP20-11B	RSP20-11S	M20×1.5	φ20.2	6	11	10	82	24	26	1
RSP25-16B	RSP25-16S	M25×1.5	φ25.2	11	16	12	102	33	36	1

# AGM SERIES

# METAL CABLE GLAND

IP68



- High water protection IP68 (1bar / 30min) metal cable gland.
- Wide selection, for M6 ~ M50 and PG7 ~ PG16.  
Suitable for  $\Phi 2$  mm ~  $\Phi 42$  mm cable.

Technical Data
Protection class: IP68 1bar / 30min
Operating temperature: -40°C ~ +100°C
Compliant with EN50262 Ver. A

### AGM Series

Thicker sealing insert evenly hold a cable by having a larger holding area. Remains durable even after repeated tightening / loosening.

### Lamellar insert type

If over-tightened, it can cause the rubber bush or cable to deform, which can allow water to seep in.

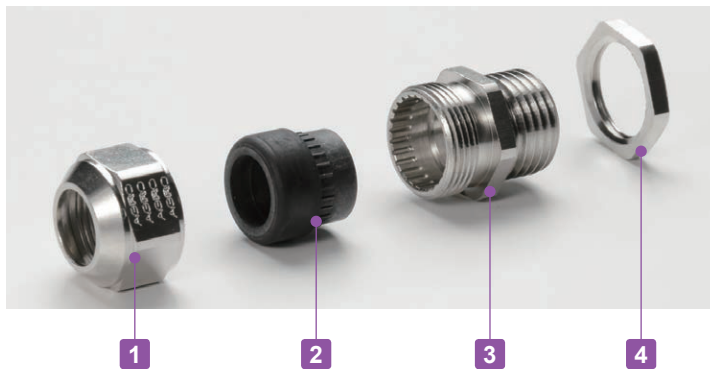
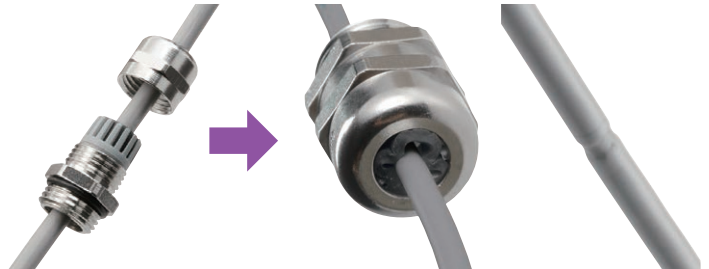
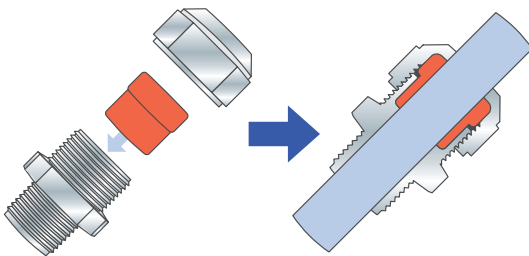

- Proper tightening torque varies by each cable diameter.  
Tighten the cap until top of the sealing insert forms a small bead between the cap and the cable.



### Components

No.	Part name	Material	Color / Finish
1	Cap	Brass	Nickel plated
2	Sealing insert	TPE	Black
3	Connector	Brass	Nickel plated
-	O-ring	NBR	Black
4	Lock nut	Brass	Nickel plated

AGM dimensions

DXF/DWG/PDF drawings available on our website.

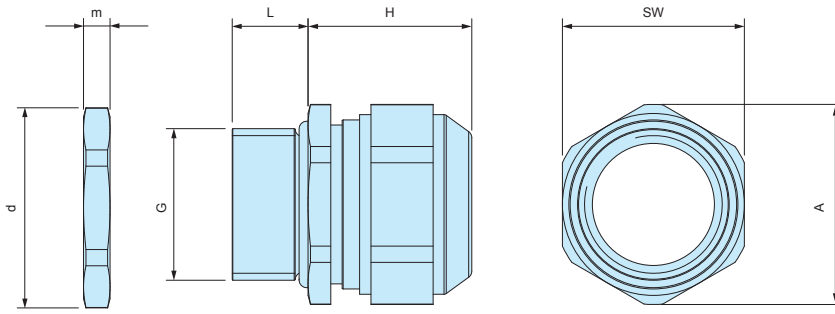

Product no. / Dimensions

Product no.	G			Cable range		L	H Max	SW	A	d	m	Pack of
	Thread size	Thread outer dia.	Mounting hole	Min	Max							
AGM6-2.5	M6×1.0	—	Φ6.2	2	2.5	8	12	8	9	10	2.8	1
AGM6-3	M6×1.0	—	Φ6.2	2.5	3.0	8	12	8	9	10	2.8	1
AGM6-3.5	M6×1.0	—	Φ6.2	3.0	3.5	8	12	8	9	10	2.8	1
AGM8-5	M8×1.25	—	Φ8.2	3.5	4.7	10	14	11	12	12	3	1
AGM10-6	M10×1.5	—	Φ10.2	4.0	6.0	10	15	13	14.3	14	2.8	1
AGM12-8	M12×1.5	—	Φ12.2	6.5	8.0	10	17	15	16.5	16.5	2.8	1
AGM16-10.5	M16×1.5	—	Φ16.2	8.0	10.5	10	21	18	20	21	3	1
AGM20-15	M20×1.5	—	Φ20.2	11.0	15.0	10	23	24	26.5	26.5	3.5	1
AGM25-20	M25×1.5	—	Φ25.2	16.0	20.0	11	28	30	33	33	4	1
AGM32-25.5	M32×1.5	—	Φ32.3	21.0	25.5	13	29.5	36	39.5	39.5	4	1
AGM40-28.5	M40×1.5	—	Φ40.3	24.0	28.5	13	32	46	50.7	51	5	1
AGM40-33	M40×1.5	—	Φ40.3	28.5	33.0	13	32	46	50.7	51	5	1
AGM50-37	M50×1.5	—	Φ50.4	33.0	37.0	14	34	55	59.7	60	5.5	1
AGM50-42	M50×1.5	—	Φ50.4	37.0	42.0	14	34	55	59.7	60	5.5	1
AGM7PG-5	PG7	12.5	Φ12.7	3.5	5.0	6	17	15	16.5	16.5	3	1
AGM9PG-6	PG9	15.2	Φ15.4	4.5	6.0	6	20	18	20	20	3	1
AGM11PG-8.5	PG11	18.6	Φ18.8	5.5	8.5	6	21	21	23	23.5	3	1
AGM13PG-11	PG13	20.4	Φ20.6	8.0	11.0	6	21	24	26.5	25.5	3	1
AGM16PG-14.5	PG16	22.5	Φ22.7	11	14.5	6	23	24	26.5	29	3	1

# AGE SERIES

# EMC SHIELDED CABLE GLAND



- Optimal contact spring provides excellent shield contact and the smallest possible transfer impedance.
- Clawed lock nut makes a good EMC shield contact possible on conductive enclosures.
- Shape of the contact spring not only allows for a large clamping range to the shield but also enables easy and faster installation and re-installation.
- 2-piece detachable sealing inserts can be adapted to the wider existing cable diameter on site.  
(AGE12 available only with 1-piece sealing insert)

Technical Data	
Protection class :	IP68 2bar / 30min, IP69K
	20m depth immersion in 30 minutes
Operating temperature :	-60°C ~ +100°C
	Compliant with IEC62444 Var. A

### Cable Range

No.	Sealing insert type	
	Assembled	Detached
AGE16-10.5	Φ 6 ~ Φ 7.5	Φ 7.5 ~ Φ10.5
AGE20-15	Φ 8 ~ Φ10.5	Φ10.5 ~ Φ15
AGE25-20	Φ12.5 ~ Φ15	Φ15 ~ Φ20
AGE32-25	Φ17 ~ Φ20	Φ20 ~ Φ25

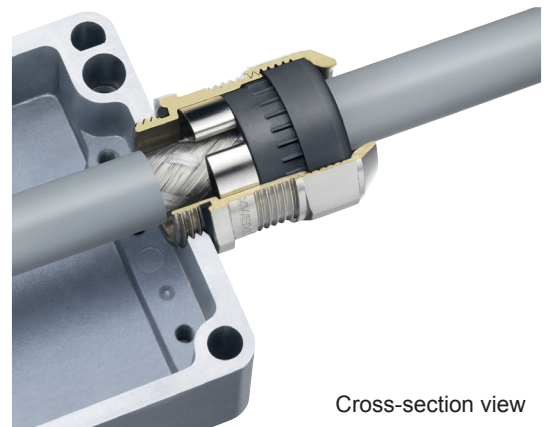
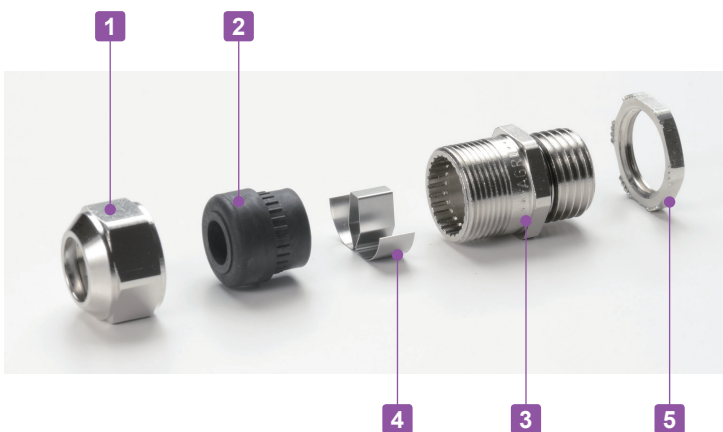
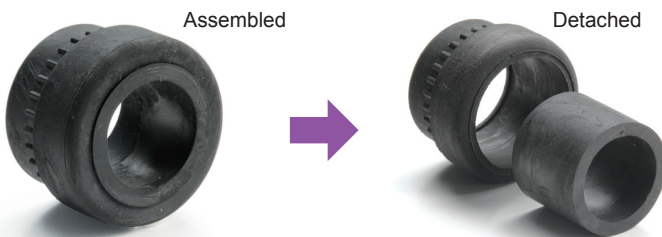

Cross-section view

### Components

No.	Part name	Material	Color / Finish
1	Cap	Brass	Nickel plated
2	Sealing insert	TPE	Black
3	Connector	Brass	Nickel plated
4	Contact spring	Stainless steel	Unfinished
-	O-Ring	NBR	Black
5	Lock-nut	Brass	Nickel plated

**INSTALLATION Instruction**

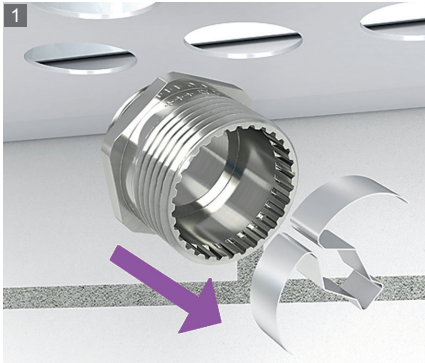

1 Remove the contact spring from the connector.



2 Install the connector onto the enclosure.



3 Strip the cable.

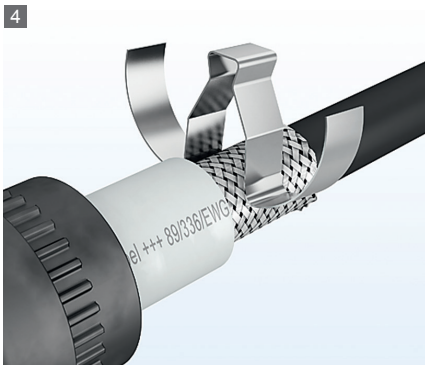

4 Clip the contact spring on the shielded cable.



5 Pass the cable through the Sealing insert and cap.



6 Tighten the cap to complete.

**AGE dimensions**

■ DXF/DWG/PDF drawings available on our website.

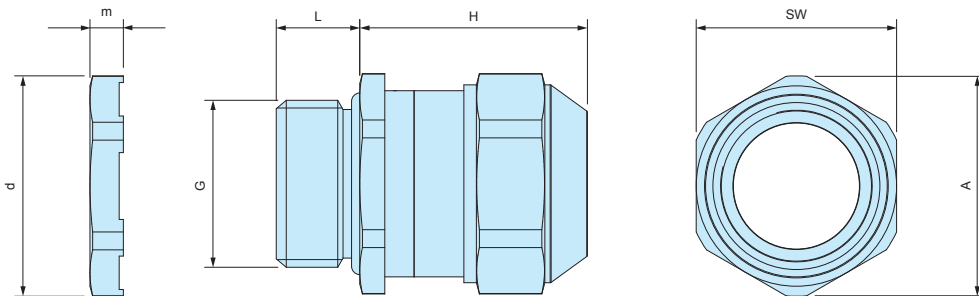

**Product no. / Dimensions**

Product no.	G		Cable range		L	H Max	SW	A	d	m	Pack of
	Thread size	Mounting hole	Min	Max							
AGE12-5	M12×1.5	Φ12.2	3.5	5.0	10	22	15	16.5	16.5	3.5	1
AGE12-6.5	M12×1.5	Φ12.2	5.0	6.5	10	22	15	16.5	16.5	3.5	1
AGE16-10.5	M16×1.5	Φ16.2	6.0	10.5	10	25	18	20	21	3.5	1
AGE20-15	M20×1.5	Φ20.2	8.0	15.0	10	27	24	26.5	26.5	4	1
AGE25-20	M25×1.5	Φ25.2	12.5	20.0	11	33	30	33	33	4	1
AGE32-25	M32×1.5	Φ32.3	17.0	25.0	13	34	36	39.5	39.5	5	1

# AGH SERIES

# HEAT RESISTANT METAL CABLE GLAND



- Heat resistant sealing insert made of FPM material. Resistant up to 200°C
- IP68 1bar / 30min high performance waterproof cable gland.

Technical Data
Protection class : Protection class IP68 1bar / 30min 10m depth immersion in 30 minutes
Operating temperature : -40°C ~ +200°C
Compliant with EN50262 Var. A

### AGH series

Thicker sealing insert evenly clasp onto the cable by having a larger area. Remains durable even after repeated tightening / loosening.

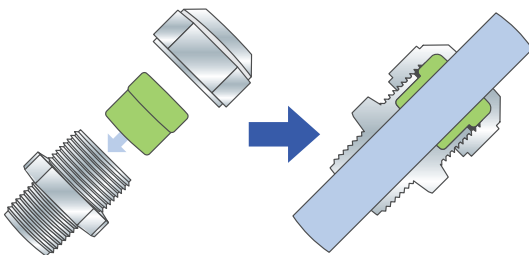

### Conventional cable gland

If over-tightened, it can cause the rubber bush or cable to deform, which may allow water to seep in.

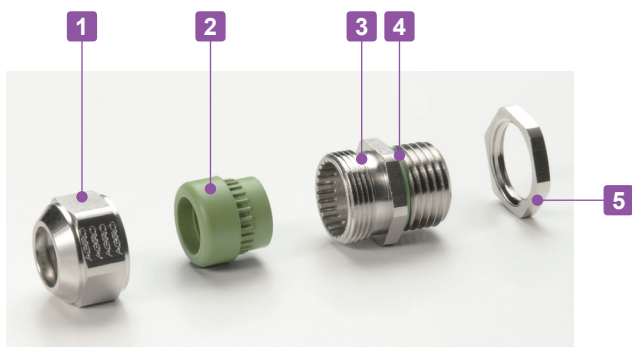
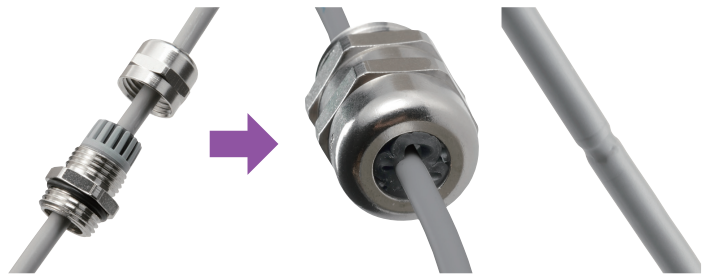

- Tightening torque varies depending on the cable diameter. Tighten until the sealing insert protrudes slightly from the cap.

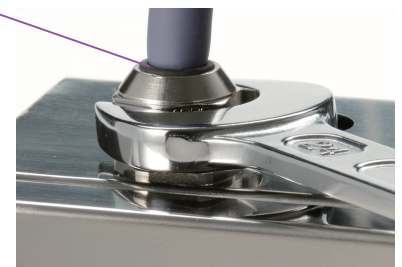

### Components

No.	Part name	Material	Color / Finish
1	Cap	Brass	Nickel plated
2	Sealing insert	FPM	Green
3	Connector	Brass	Nickel plated
4	O-Ring	FPM	Green
5	Lock-nut	Brass	Nickel plated

**AGH dimensions**

■ DXF/DWG/PDF drawings available on our website.

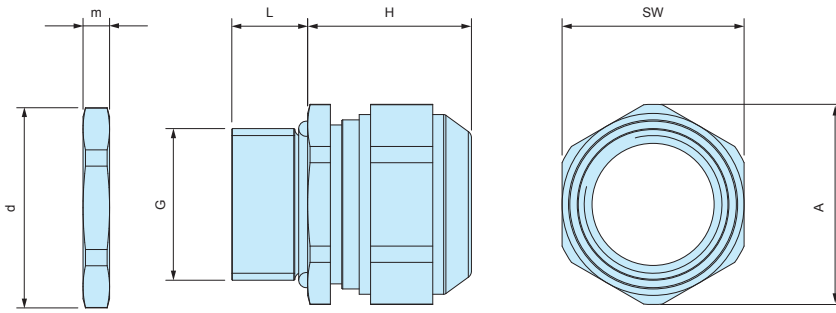

**Product no. / Dimensions**

Product no.	G		Cable range		L	H Max	SW	A	d	m	Pack of
	Thread size	Mounting hole	Min	Max							
AGH10-6	M10×1.5	Φ10.2	4.0	6.0	10	15	13	14.3	14.2	3	1
AGH12-8	M12×1.5	Φ12.2	6.5	8.0	10	17	15	16.5	16.5	3	1
AGH16-10.5	M16×1.5	Φ16.2	8.0	10.5	10	20	18	20	21	3	1
AGH20-15	M20×1.5	Φ20.2	11.0	15.0	10	23	24	26.5	26.3	3.5	1
AGH25-20	M25×1.5	Φ25.2	16.0	20.0	11	27	30	33	33	4	1
AGH32-25.5	M32×1.5	Φ32.3	21.0	25.5	13	28.5	36	39.7	39.7	4	1