

NANUK™

PROFESSIONAL PROTECTIVE CASES

THE FUTURE OF PROTECTION CASES

Tough yet stylish.
Durable and elegant.
Easily customizable.
Endless possibilities abound.



OUTDOOR



NANUK-1

MEASUREMENT



DRONE



MEDICAL



TRANSPORT



DEFENCE



NANUK™ THE NANUK ADVANTAGE

IP65 PROTECTION CLASS

IP65 protection class for use in various environments.

Equipped with durable and weather resistant EPDM gasket.

Waterproof pressure relief valve enables pressure within the case to be equalized with the surrounding, allowing it to be opened with ease, while keeping it waterproof.



IMPACT RESISTANT-NK-7 RESIN

Impact resistant, lightweight, and armed with reinforced PP, NK-7 resin body.

Keep your items safe from impact damage.



22 DIFFERENT SIZES

A large selection of 22 different sizes, ranging from small (148.5 x 109.5 x 43mm) to large (1,196 x 440 x 168mm) types.

Smallest 3 sizes are available in 5 different colors: black, white, clear, lime and marine colors.

Other sizes are available in either black or yellow.



PROTECTIVE SPONGE FOAM

Nanuk cases are also available with a protective sponge foam.

Sponge foam are fitted to the case, and can also be purchased as separate option (NKSP series).

NKSP sponge foam comes with pre-cubed foam to allow for easy modification by removing the required squares.

(※No pre-cubed foam available for NKSP990).

Sponge customization is also available.

(See page SP-Custom-1~SP-Custom-2)



POWERCLAW LATCHING SYSTEM and SOFT GRIP HANDLE

NANUK's patented PowerClaw latching system uses compressive force to keep your case tightly clamped.

Integrated slide lock offers added security, preventing it from accidental opening during transport or when dropped.

NANUK's TPE soft grip handle makes carrying not only comfortable, but also convenient.

Handle can be folded down to be flushed with the case when not in use.



※Latch with TSA lock on NKK series



100% STAINLESS STEEL PARTS

Metallic parts are made from SUS304 stainless steel.

Suitable to be used in environments with water splashes and so on.



OPTIONAL ALUMINIUM PANEL for YOUR DEVICE

Optional aluminium panel can make NANUK into your original controller, measuring device or transmitter.

See page NKAP-1 for the details of optional aluminium panel.

NKAP panel customization is available. (See NKAP-2 for more details).

●CUSTOMIZATAION on ALUMINIUM PANEL



CUSTOMIZE



NK SERIES

IP65 CARRYING CASE



- Durable and stylishly designed waterproof carrying case.
- Selectable in 18 different sizes, with each model available with, and without foam.
- Suitable for storing electronics and delicate devices such as measuring device, camera, broadcasting device, electric tool, medical equipment, and so on.
- Optional aluminium panel can turn the NK series into your own original controller, measuring device or transmitter.



Technical Data	
Protection class :	IP65
Operating temperature :	-20°C~+60°C



Hinge pin shape varies based on model type

Components

No.	Part name	Material
1	Cover · Base	Reinforced PP (NK-7)
2	Latch	Nylon 66
3	Handle grip	Elastomer
4	Pressure release valve (※1)	Nylon 66 · PTFE

No.	Part name	Material
5	Hinge pin	Stainless steel
6	Gasket	EPDM
7	Foam	Polyurethane / 12.7mm Pitch Pre-cut cubed foam (※2)

※1 Automatic pressure release valve enables pressure within the case to be equalized with the surrounding, allowing it to be opened with ease, while keeping it waterproof.
 ※2 Pitch of Pre-cut cubed foam for NK940, 945, and 950 models is 15mm.

Accessories(Optional parts)



Divider DVI series
See page NANUK-ACC-1



Aluminium panel NKAP series
See page NKAP-1~NKAP-2



Shoulder strap NSTP series
See page NANUK-ACC-3



Padlock AB145S series
See page NANUK-ACC-3



Nameplate sticker NKST series
See page NANUK-ACC-3

■ Standard Type and Foam Type are available.

NK dimensions

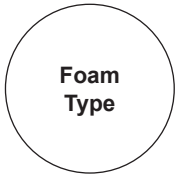
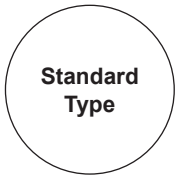

■ Drawings below are reference examples only.
DXF/DWG/PDF drawings available on our website.

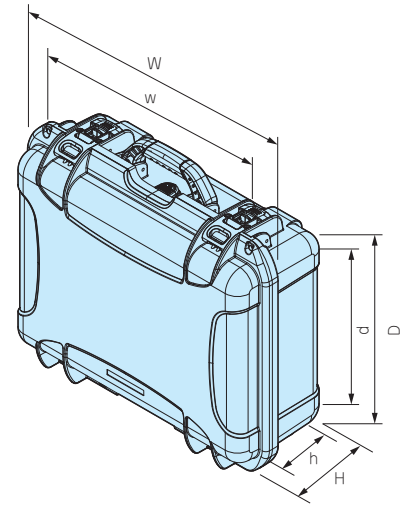

※ See page NANUK-ACC-2 pages for optional NKSP foam.

Product no. / Dimensions

■ Standard type (without foam)

Product no.		Dimensions (External)			Dimensions (Internal)			Weight (kg)
● Black	● Yellow	W	D	H	w	d	h	
NK903B	NK903Y	231	173	97	180	114	79	0.6
NK904B	NK904Y	259	201	114	200	135	94	0.7
NK905B	NK905Y	318	257	152	220	170	131.5	1.6
NEW NK908B	NEW NK908Y	318	249	203	215	165	181	1.5
NEW NK909B	NEW NK909Y	321	229	111	268	151	86	1.0
NK910B	NK910Y	363	282	120	320	210	95.5	1.4
NK915B	NK915Y	393.5	307	173	320	210	152	2.1
NK918B	NK918Y	427	328	236	350	215	212	2.9
NK920B	NK920Y	424	340	173	360	240	152	2.4
NEW NK923B	NEW NK923Y	472	366	160	391	253	128	2.7
NK925B	NK925Y	475	376	178	410	270	159	2.9
NK930B	NK930Y	503	406	193	430	310	171	3.4
NK933B	NK933Y	503	409	254	430	300	233	3.9
NK935B	NK935Y	559	356	229	415	265	179	5.3
NK940B	NK940Y	557	429	216	480	320	197	3.9
NK945B	NK945Y	638	505	224	530	400	202	5.0
NK950B	NK950Y	579	465	297	420	360	247	7.0
NK960B	—	645	508	368	470	365	316	9.0

■ Foam type (with foam)

Product no.		Dimensions (External)			Dimensions (Internal)			Weight (kg)
● Black	● Yellow	W	D	H	w	d	h	
NK903BS	NEW NK903YS	231	173	97	180	114	79	0.63
NK904BS	NEW NK904YS	259	201	114	200	135	94	0.81
NK905BS	NEW NK905YS	318	257	152	220	170	131.5	1.7
NEW NK908BS	NEW NK908YS	318	249	203	215	165	181	1.7
NEW NK909BS	NEW NK909YS	321	229	111	268	151	86	1.2
NK910BS	NEW NK910YS	363	282	120	320	210	95.5	1.5
NK915BS	NEW NK915YS	393.5	307	173	320	210	152	2.4
NK918BS	NEW NK918YS	427	328	236	350	215	212	2.9
NK920BS	NEW NK920YS	424	340	173	360	240	152	2.7
NEW NK923BS	NEW NK923YS	472	366	160	391	253	128	3.1
NK925BS	NEW NK925YS	475	376	178	410	270	159	3.3
NK930BS	NEW NK930YS	503	406	193	430	310	171	3.9
NK933BS	NEW NK933YS	503	409	254	430	300	233	4.6
NK935BS	NEW NK935YS	559	356	229	415	265	179	6.0
NK940BS	NEW NK940YS	557	429	216	480	320	197	4.6
NK945BS	NEW NK945YS	638	505	224	530	400	202	6.0
NK950BS	NEW NK950YS	579	465	297	420	360	247	8.0
NK960BS	—	645	508	368	470	365	316	10.5

NKK SERIES

IP65 CARRYING CASE with LOCK



- Equipped with a TSA lock latch for security, or transportation as check-in baggage.
- Available in 15 different sizes, with 2 different types available Without foam and With foam.
- Optional aluminium panel can turn the NKK series into your own original controller, measuring device or transmitter.



Technical Data	
Protection class :	IP65
Operating temperature :	-20°C~+60°C



Latch with TSA lock



2 Keys included.

What is TSA LOCK?

TSA LOCK is a global security system which allows passengers to lock their luggage, while at the same time, permitting security authorities to inspect them without damage to the lock or luggage.



Accessories(Optional parts)



Divider DVI series
See page NANUK-ACC-1



Aluminium panel NKAP series
See page NKAP-1~NKAP-2



Shoulder strap NSTP series
See page NANUK-ACC-3



Foam NKSP series
See page NANUK-ACC-2



Nameplate sticker NKST series
See page NANUK-ACC-3



Hinge pin shape varies based on model type

Components

No.	Part name	Material
1	Cover · Base	Reinforced PP (NK-7)
2	Latch	Nylon 66 · Zinc alloy
3	Handle grip	Elastomer
4	Pressure release valve (※1)	Nylon 66 · PTFE
5	Hinge pin	Stainless steel

No.	Part name	Material
6	Gasket	EPDM
7	Foam	Polyurethane / 12.7mm Pitch Pre-cut cubed foam (※2)
8	Key	Brass · PP

※1 Automatic pressure release valve enables pressure within the case to be equalized with the surrounding, allowing it to be opened with ease, while keeping it waterproof.

※2 Pitch of Pre-cut cubed foam for NK940, 945, and 950 models is 15mm.

NKK945 and NKK960 models

Only 2 latches (below illustration) are equipped with TSA lock (out of 4 latches).

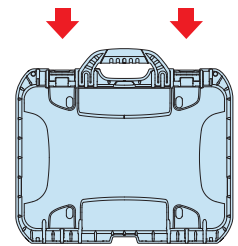

Product no. / Dimensions

Standard type (without foam)

Product no.	Dimensions (External)			Dimensions (Internal)			Weight (kg)
	W	D	H	w	d	h	
● Black							
NKK905B	318	257	152	220	170	131.5	1.6
NEW NKK908B	318	249	203	215	165	181	1.5
NKK915B	393.5	307	173	320	210	152	2.1
NKK918B	427	328	236	350	215	212	2.9
NKK920B	424	340	173	360	240	152	2.4
NEW NKK923B	472	366	160	391	253	128	2.7
NKK925B	475	376	178	410	270	159	2.9
NKK930B	503	406	193	430	310	171	3.4
NKK933B	503	409	254	430	300	233	3.9
NKK935B	559	356	229	415	265	179	5.3
NKK940B	557	429	216	480	320	197	3.9
NKK945B	638	505	224	530	400	202	5.0
NKK950B	579	465	297	420	360	247	7.0
NKK960B	645	508	368	470	365	316	9.0
NEW NKK990B	1,196	440	168	1,070	340	143.5	8.3

NKK990 model

Only 2 latches (below illustration) are equipped with TSA lock (out of 4 latches).

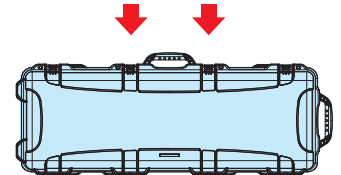

NKK dimensions

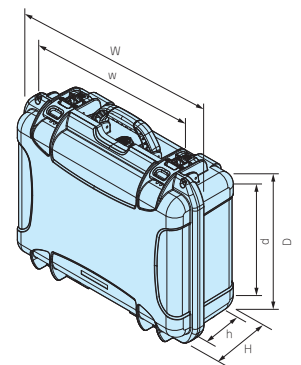

Foam type (with foam)

Product no.	Dimensions (External)			Dimensions (Internal)			Weight (kg)
	W	D	H	w	d	h	
● Black							
NEW NKK905BS	318	257	152	220	170	131.5	1.7
NEW NKK908BS	318	249	203	215	165	181	1.7
NEW NKK915BS	393.5	307	173	320	210	152	2.4
NEW NKK918BS	427	328	236	350	215	212	2.9
NEW NKK920BS	424	340	173	360	240	152	2.7
NEW NKK923BS	472	366	160	391	253	128	3.1
NEW NKK925BS	475	376	178	410	270	159	3.3
NEW NKK930BS	503	406	193	430	310	171	3.9
NEW NKK933BS	503	409	254	430	300	233	4.6
NEW NKK935BS	559	356	229	415	265	179	6.0
NEW NKK940BS	557	429	216	480	320	197	4.6
NEW NKK945BS	638	505	224	530	400	202	6.0
NEW NKK950BS	579	465	297	420	360	247	8.0
NEW NKK960BS	645	508	368	470	365	316	10.5
NEW NKK990BS	1,196	440	168	1,070	340	143.5	9.8

NK • NKK dimensions

DXF/DWG/PDF drawings available on our website.

NK 903

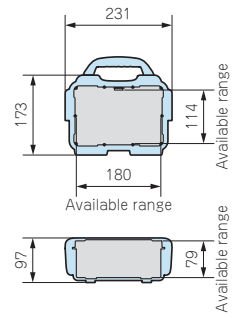

NK 904

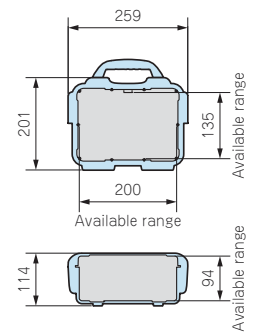

NK/NKK 905

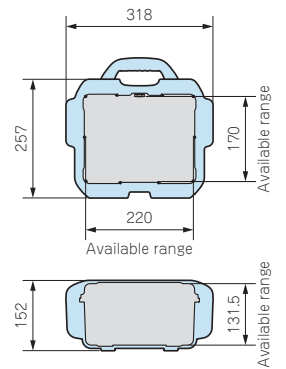

NK/NKK 908 NEW

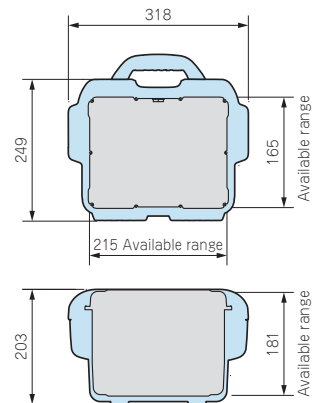

NK • NKK-1

NK • NKK dimensions

DXF/DWG/PDF drawings available on our website.

NK 909 NEW

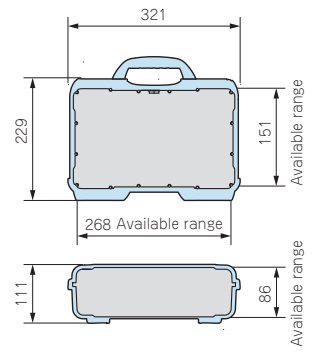

NK 910

NK910 is able to install optional aluminium panels on both the cover and base. (See page NKAP-1~NKAP-2)

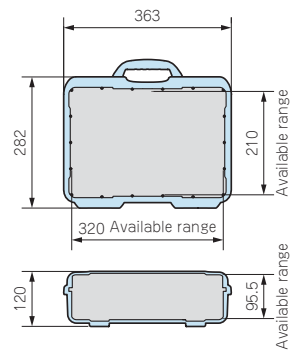

NK/NKK 915

APPLICATION EXAMPLE

EDUCATIONAL TABLET AID PACK
Product by FUJISOFT (Japan)

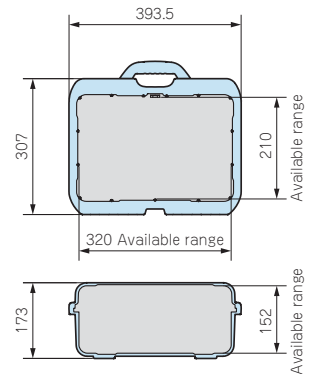

NK/NKK 918

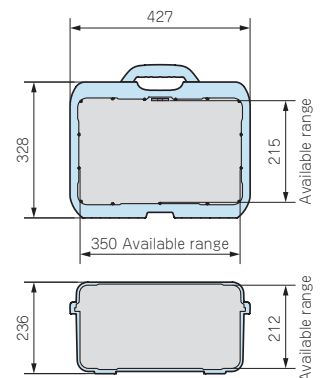

NK • NKK dimensions

■ DXF/DWG/PDF drawings available on our website.

NK/NKK 920

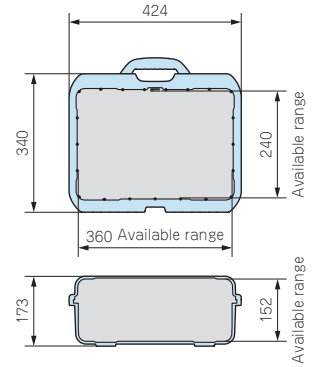

NK/NKK 923 NEW

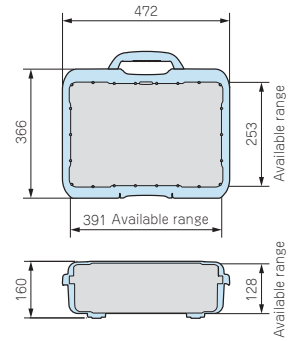

NK/NKK 925



APPLICATION EXAMPLE
ELECTRIC PROSPECTING / LOGGING DEVICE
Product by OYO CORPORATION (Japan)

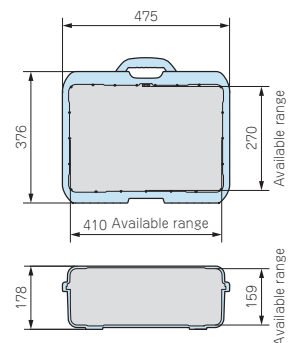

NK • NKK dimensions

DXF/DWG/PDF drawings available on our website.

NK/NKK 930

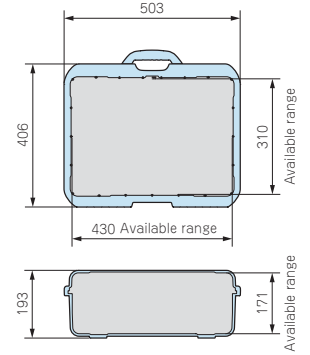

APPLICATION EXAMPLE

PRESS BREAK CHECKER
Product by Shinohara Press Service (Japan)

NK/NKK 933

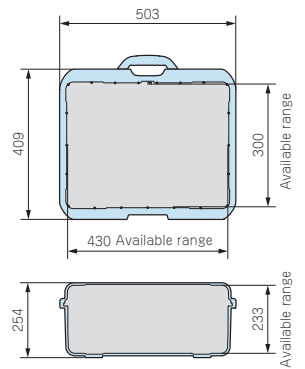

NK/NKK 935

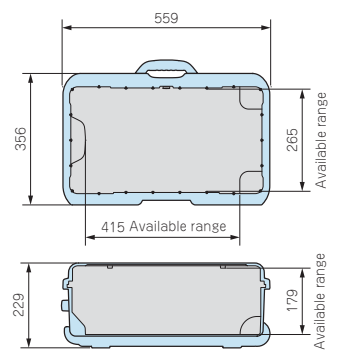

Equipped with a 2 stage retractable handle and polyurethane wheels.

Cover can be detached by pulling out the hinge pin.
※Hinge pin shape varies based by model type.

NK/NKK 940

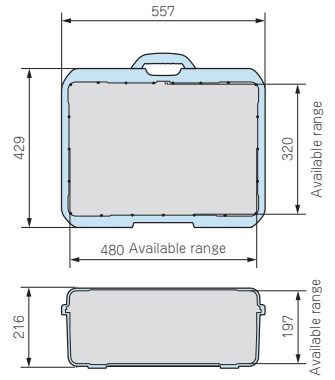

NK/NKK 945

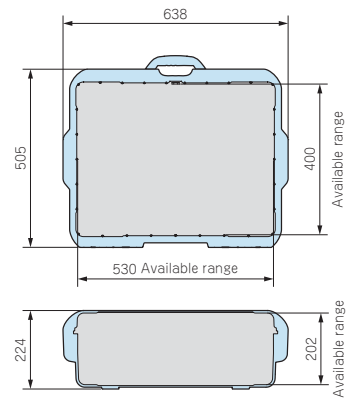

NK/NKK 950

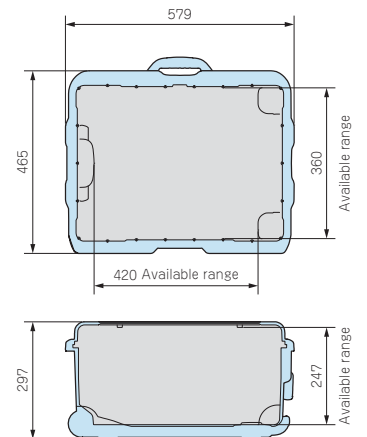

Equipped with a 2 stage retractable handle and polyurethane wheels.

NK • NKK dimensions

DXF/DWG/PDF drawings available on our website.

NK/NKK 960

※ () values are for NK • NKK935 and 950 models.



Equipped with a 2 stage retractable handle and polyurethane wheels.

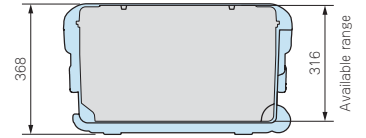
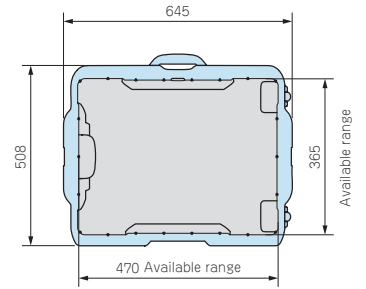

NKK 990



Equipped with polyurethane wheels.

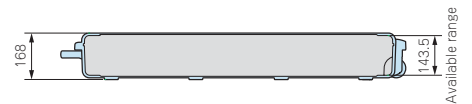
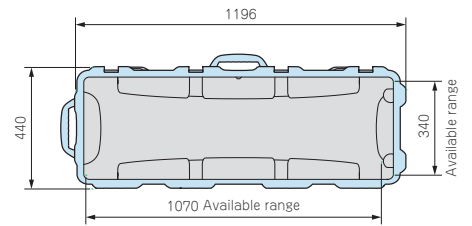

NANO SERIES

WATERPROOF PORTABLE CASE



- IP65 waterproof compact and stylish case.
- Slit holes on both sides for strap or belt.
- Suitable for storing small electric devices such as mobile phones, wireless devices, portable radios, and so on.



Technical Data
Protection class : IP65
Operating temperature : -20°C~+60°C

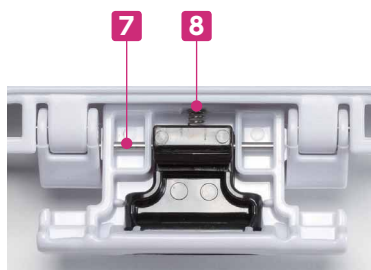

Latch (lock mechanism) side



Hinge Side

● How To Use Strap



Insertion of clip into the case



Use as handy strap



Insert strap end into the loop after clip insertion.



Fix it to the belt loop, etc.

Components

No.	Part name	Material
1	Cover · Base	Polycarbonate
2	Protective net	Silicone
3	Lock lever	Polycarbonate
4	Corner guard	Elastomer
5	Gasket	Elastomer
6	Strap	Nylon · Nylon 66
7	Latch pin	Stainless steel
8	Spring	Stainless steel
9	Pressure relief valve (※)	Nylon 66 · PTFE

※ Waterproof pressure relief valve enables pressure within the case to be equalized with the surrounding, allowing it to be opened with ease, while keeping it waterproof.

NANO dimensions

■ Drawings below are reference examples only.
DXF/DWG/PDF drawings available on our website.

NANO 310

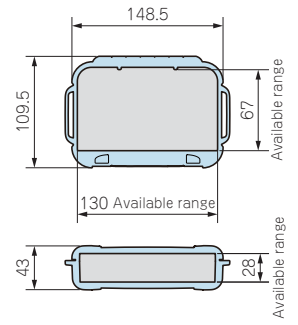

NANO 320

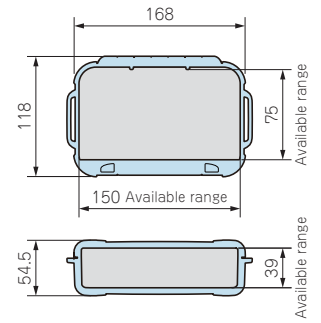

NANO 330

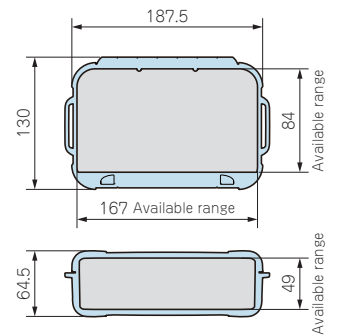

Product no. / Dimensions

Product no.					Dimensions (External)			Dimensions (Internal)			Weight (g)
● Black	● White	● Clear	● Lime	● Marine	W	D	H	w	d	h	
NANO310B	NANO310W	NANO310C	NANO310L	NANO310M	148.5	109.5	43	130	67	28	265
NANO320B	NANO320W	NANO320C	NANO320L	NANO320M	168	118	54.5	150	75	39	350
NANO330B	NANO330W	NANO330C	NANO330L	NANO330M	187.5	130	64.5	167	84	49	450

Applicable for use as electronic and communication devices

PCB can be installed with PCB mounting screw MT series.
NANO series can also be used as a pole mounted communication device.



Accessories(Optional parts)



Aluminium panel NKAP series
See page NKAP-1~NKAP-2



PCB mounting screw MT series
See page NKAP-1



Nameplate sticker NKST series
See page NANUK-ACC-3



NKAP SERIES

ALUMINIUM PANEL for NANO · NK · NKK

← NEW SIZE →



Optional aluminium panel can be used as a controller control / display, measuring device, transmitter, and so on.

Drawings below are reference examples only. DXF/DWG/PDF drawings available on our website.

NKAP dimensions

NANO series

Slide insert and screw fastening

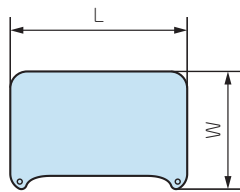

NK · NKK series

Required screws vary based on size

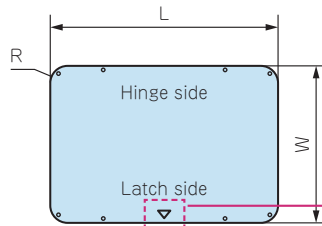

※Install panel with ▽marking towards the latch.

Components

No.	Part name	Material
1	Panel	Aluminium (Anodized)
2	Screw	Stainless steel



Product no. / Dimensions

Product no.	Suitable case	Thickness	L	W	R	▽ marking	Screw pcs	Weight (g)
NKAP310	NANO310	2	136.2	90.6	13	—	2	59
NKAP320	NANO320	2	156.8	100.4	15.7	—	2	75
NKAP330	NANO330	2	175.9	112.2	17	—	2	94
NKAP903	NK903	1.5	198.5	136.5	15	—	4	109
NKAP904	NK904	1.5	226	163.5	18	—	4	149
NKAP905	NK/NKK905	1.5	257	207	21.5	—	4	214
NEW NKAP908	NK/NKK908	1.5	250.9	200.1	18	—	4	203
NEW NKAP909	NK909	1.5	304.7	190.4	18	—	4	234
NKAP910	NK910 base side	2	346	244.5	17	—	4	452
NKAP910C	NK910 cover side	1.5	339.5	238	14	—	4	329
NKAP915	NK / NKK915	2	368.5	254	28	○	8	496
NKAP918	NK / NKK918	2	397.5	268.5	27	—	8	574
NKAP920	NK / NKK920	2	399.5	285	28	○	8	606
NEW NKAP923	NK / NKK923 base side	2	446.3	309.1	28	—	8	737
NEW NKAP923C	NK / NKK923 cover side	2	438.3	301.1	23.5	—	8	704
NKAP925	NK/NKK925	2	451.5	318	28	○	8	760
NKAP930	NK/NKK930	2	476	350.5	27	○	8	880
NKAP933	NK/NKK933	2	477.5	352	27	—	8	908
NKAP935	NK/NKK935	2	535	301.5	26.5	○	8	855
NKAP940	NK/NKK940	2	526.5	374	27	○	10	1,050
NKAP945	NK/NKK945	2	576.5	450	26.5	○	10	1,395
NEW NKAP950	NK/NKK950	2	540.8	409.1	27	—	10	1,179
NEW NKAP960	NK/NKK960	2	579.7	454.2	27	—	10	1,402

MT SERIES

PCB MOUNTING SCREW for NANO

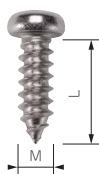

PCB should be the same size as NKAP series aluminium panel.
Insert PCB into groove (see diagram to the right) and screw into the screw marking.

Product no. / Dimensions

Product no.	M	L	Pcs
MT2.6-8T	2.6	8	2

Material : Stainless steel

CUSTOMIZATION on ALUMINIUM PANEL

- Customization services such as CNC milling, punching press, digital inkjet printing, silkscreen printing, and engraving on NKAP panel are available.
- Custom colors can also be performed either through anodization, or painting.



- Self-clinching Standoff/Stud/Nut or Welded Fastener customization is available.



- An original control panel with machined aluminum panel and overlay sheet can be performed.



DVI SERIES

DIVIDER for NK · NKK

NEW SIZE



- Divider for organizing your components or equipment. Adjustable hook and loop fasteners allows for easily size adjustments.
- Padded dividers are designed to easily organize and protect your equipment.

APPLICATION EXAMPLE



DVI905 / 908

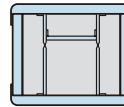

DVI915 / 918

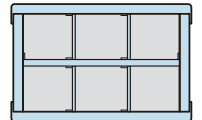

DVI920



DVI923 / 925

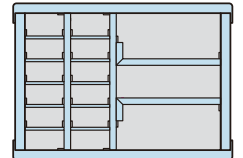

DVI930 / 933



DVI935

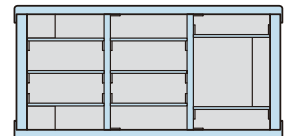

DVI940



DVI945

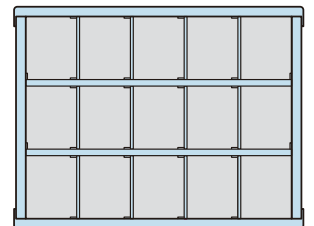

DVI950

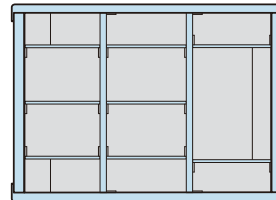

DVI960 ※2 divider layers available.

▼1st layer

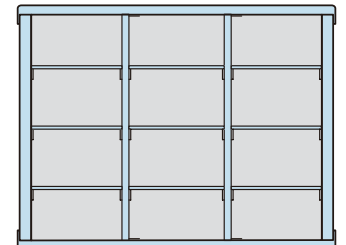

▼2nd layer

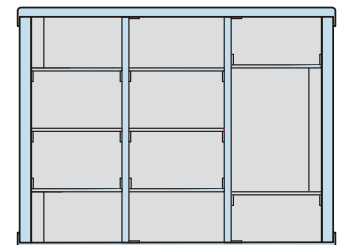

Product no. / Suitable case

Product no.	Suitable case	Weight (g)
DVI905	NK/NKK905	288
NEW DVI908	NK/NKK908	453
DVI915	NK/NKK915	542
DVI918	NK/NKK918	800
DVI920	NK/NKK920	753
NEW DVI923	NK/NKK923	1,025
DVI925	NK/NKK925	968
DVI930	NK/NKK930	1,220
DVI933	NK/NKK933	1,500
DVI935	NK/NKK935	1,190
DVI940	NK/NKK940	1,695
DVI945	NK/NKK945	1,940
DVI950	NK/NKK950	1,810
DVI960	NK/NKK960	3,230

NKSP SERIES

SPONGE FOAM for NK • NKK

← NEW SIZE →

- Pre-cubed foam can be easily cut to make a suitable storage space.
- Available as three-layered foam set with waved (for cover side), pre-cubed foam (for base side) and base layer.
- ※ Pre-cubed foam layer is not available for NKSP990 model.

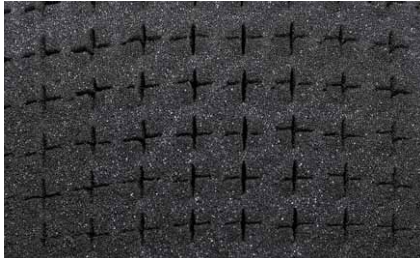
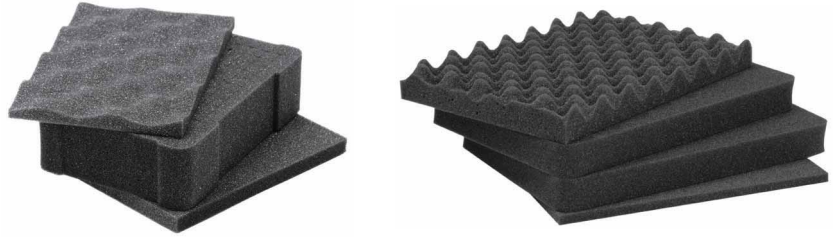

- Drawings below are reference examples only. DXF/DWG/PDF drawings available on our website.

Product no. / Suitable case

Product no.	Suitable case	Foam layer details	Cut-line pitch	Weight (g)
NKSP903	NK903	Waved layer x 1 · Pre-cubed foam layer x 1 · Base layer x 1	12.7	40
NKSP904	NK904	Waved layer x 1 · Pre-cubed foam layer x 1 · Base layer x 1	12.7	70
NKSP905	NK/NKK905	Waved layer x 1 · Pre-cubed foam layer x 1 · Base layer x 1	12.7	120
NEW NKSP908	NK/NKK908	Waved layer x 1 · Pre-cubed foam layer x 2 · Base layer x 1	12.7	158
NEW NKSP909	NK909	Waved layer x 1 · Pre-cubed foam layer x 1 · Base layer x 1	12.7	158
NKSP910	NK910	Waved layer x 1 · Pre-cubed foam layer x 1 · Base layer x 1	12.7	150
NKSP915	NK/NKK915	Waved layer x 1 · Pre-cubed foam layer x 2 · Base layer x 1	12.7	250
NKSP918	NK/NKK918	Waved layer x 1 · Pre-cubed foam layer x 3 · Base layer x 1	12.7	390
NKSP920	NK/NKK920	Waved layer x 1 · Pre-cubed foam layer x 2 · Base layer x 1	12.7	320
NEW NKSP923	NK/NKK923	Waved layer x 1 · Pre-cubed foam layer x 2 · Base layer x 1	12.7	399
NKSP925	NK/NKK925	Waved layer x 1 · Pre-cubed foam layer x 2 · Base layer x 1	12.7	430
NKSP930	NK/NKK930	Waved layer x 1 · Pre-cubed foam layer x 2 · Base layer x 1	12.7	540
NKSP933	NK/NKK933	Waved layer x 1 · Pre-cubed foam layer x 3 · Base layer x 1	12.7	700
NKSP935	NK/NKK935	Waved layer x 1 · Pre-cubed foam layer x 2 · Base layer x 1	12.7	710
NKSP940	NK/NKK940	Waved layer x 1 · Pre-cubed foam layer x 2 · Base layer x 1	15	730
NKSP945	NK/NKK945	Waved layer x 1 · Pre-cubed foam layer x 2 · Base layer x 1	15	1,000
NKSP950	NK/NKK950	Waved layer x 1 · Pre-cubed foam layer x 3 · Base layer x 1	15	1,000
NKSP960	NK/NKK960	Waved layer x 1 · Pre-cubed foam layer x 4 · Base layer x 1	12.7	1,500
NKSP990	NKK990	Waved layer x 1 · Plain foam layer x 2 · Base layer x 1	—	1,490



CUSTOMIZE



- Customization on foam is available.
- Foam customization is also available where your own unique form design and cut-outs can be performed.

CUSTOMIZED EXAMPLE



NSTP SERIES SHOULDER STRAP

■ Nylon shoulder strap with polyurethane pads to reduce fatigue when carrying.



Components

No.	Part name	Material
1	Belt	Nylon
2	Pad	Neoprene · Polyurethane
3	Hook	Steel (Black painted)

Product no. / Feature

Product no.	Weight (g)	Quantity
NSTP810	238	1

※Belt length can be adjustable from 810mm to 1,170mm
 ※Not applicable for NK903, NK904, NKK990, NK · NKK950 and NK · NKK960 models.

AB145S SERIES PADLOCK

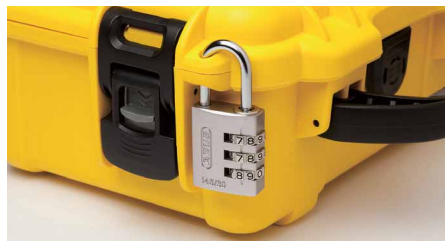
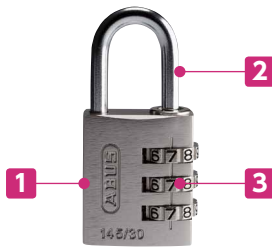

Components

No.	Part name	Material
1	Body	Aluminium
2	Shank	Steel
3	Dial	Zinc alloy

Product no. / Feature

Product no.	Weight (g)	Quantity
AB145S	52	1

NKST SERIES NAMEPLATE STICKER

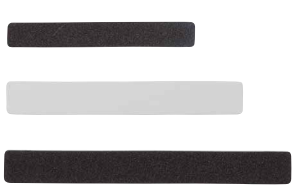

Color nameplate can be performed by digital inkjet printing on a white plate.



■ 0.3mm thick plastic nameplate with double sided tape on the back.

Custom name plate can be made with your company name, logo, product number or lot number with digital inkjet printing.

■ Digital inkjet print or silkscreen is possible from just 1 piece.

Product no. / Dimensions

Product no.		Suitable case	Dimensions		Quantity
● Black	● White		A	B	
NKST-1B	NKST-1W	NANO SERIES	50	6.8	1
NKST-2B	NKST-2W	NK903, 904	62.7	9.1	1
NKST-3B	NKST-3W	NK/NKK905 ~ 960	76.1	9.1	1

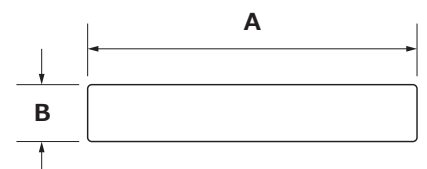

UNIQUE COLOR AVAILABLE

NANO SERIES

※See page NANO-1~NANO-2



Orange



Purple



Red

NK SERIES

※See page NK-1~NK-2



Graphite



Orange



Olive



Silver
Only available for
NK903~920
NK925~945 models



Lime
Only available for
NK903, 904, 905
908 and 910 models



Blue
Only available for
NK903 and 904
Models



Red
Only available for
NK903 and 904
Models



●For NKK series, Olive color is only available for NKK990 model.

CNC Foam Milling

Customize based on how you want it to be!

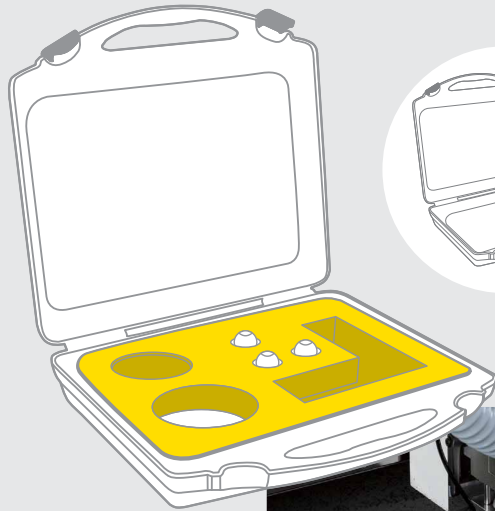

+

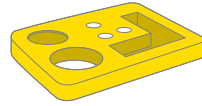

+



CNC foam cutting machine enables quick and cost-effective hole milling service.

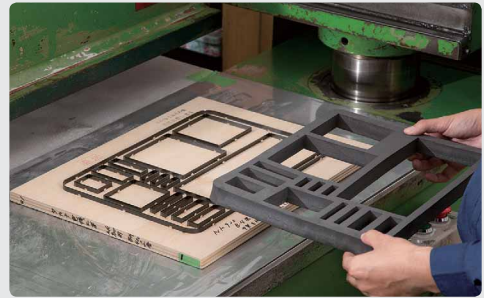

For mass production, cost-effective mold press cutting is also available.

APPLICATION EXAMPLE



CNC Machining • Printing Service for Case

CNC Machining

■ CNC machining for your switch, connector, display and so on is possible from just 1 piece.



Printing Service

■ Digital inkjet printing, silkscreen printing and nameplate sticker printing is possible from just 1 piece.

Low initial cost
No plate processing fee

Inkjet printing

Low printing cost for small quantities.

● Data adjustment fees may be charged again if significant changes are required on your repeat order.

● If the data in recommended format is provided

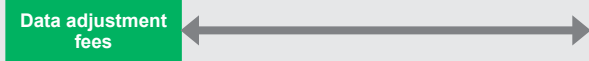

● Data or images other than recommended formats



Silk-screen initial tooling

Low printing cost for large quantity single color print.



Recommended data formats

PDF (.pdf -100%)		Vector file (.ai)		EPS (.eps)	
---------------------	--	----------------------	--	---------------	--

Initial cost can be reduced with the recommended formats.



Able to Inkjet print on rigid urethane foam.

APPLICATION EXAMPLE

