

AW · AWN · AWP IP67 ALUMINIUM ENCLOSURE

AW · AWN · AWP series are highly functional aluminium enclosures which are IP67 rated with heat dissipating heat-sink fins.

34 sizes available. Standard, Flanged, Shielding, and Silicone protector types are available.

Suitable for LED power supply, industrial camera, controller or measuring instrument where waterproof and cooling performance are crucial.

APPLICATION EXAMPLE

LIQUID LEVEL SENSOR

Product by Watty Corporation (Japan)



HEAVY DUTY PORTABLE HARDNESS TESTER

Product by DEMEQ (Argentina)



RADIO-CONTROLLED ELECTRONIC EXPLODER

Product by CODETEL (France)



OUTDOOR LED POWER SUPPLY



OPTICAL PHASE INTERROGATOR (OPI) DEVELOPMENT KIT

Product by Broadcom Limited (USA)



FBG DATA LOGGER

Product by NAGANO KEIKI (Japan)



DATA LOGGER with 3G MODEM REPORT FUNCTION

Product by mSolution (Hong Kong)



PIN HOLE DETECTOR

Product by SANKO ELECTRONIC LABORATORY (Japan)



PD ANNUNCIATOR

Product by ndb Technologies (Canada)



DC CONVERTER



CUSTOM LENGTH AVAILABLE

Flexible frame length from 50mm to 700mm in 1mm intervals.

No minimum order quantity and short lead time for small quantity order.



AW SERIES

IP67 FLANGED ALUMINIUM ENCLOSURE



- IP67 and heat dissipation enclosure. Designed with flanged end panels.
- PCB or chassis is mounted by sliding it horizontally into an inner-grooved body frame.
- Designed for a tough environment where waterproof and heat countermeasures are required.
- Suitable for outdoor use such as LED power supply and junction boxes.

Technical Data
Protection class: IP67
Operating temperature: -40°C ~ +105°C
Recommended torque: 1.0N • m (10kgf • cm)

Normal N type Components

No.	Part name	Pcs	Material	Color / Finish
1	Flanged end panel	2	Diecast aluminium ADC12	Metallic gray • Black / Powder coated
2	Body frame	1	Extruded aluminium A6063S-T5	Silver • Black / Anodized
3	Gasket	2	Silicone	Black
4	Screw	8	Stainless steel	Unfinished

EMC Shielded E type Components

No.	Part name	Pcs	Material	Color / Finish
1	Flanged end panel	2	Diecast aluminium ADC12	Silver • Black / Painted (unfinished inside)
2	Body frame	1	Extruded aluminium A6063S-T5	Silver • Black / Anodized
3	Gasket	2	Silicone	Black
4	Screw	8	Stainless steel	Unfinished

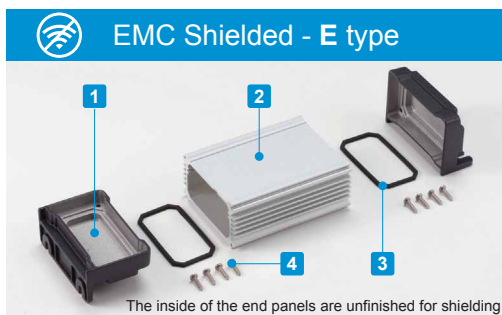
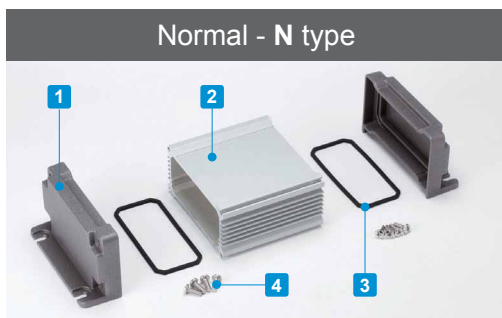

AW dimensions

■ Drawings below are reference examples only.
DXF/DWG/PDF drawings available on our website.

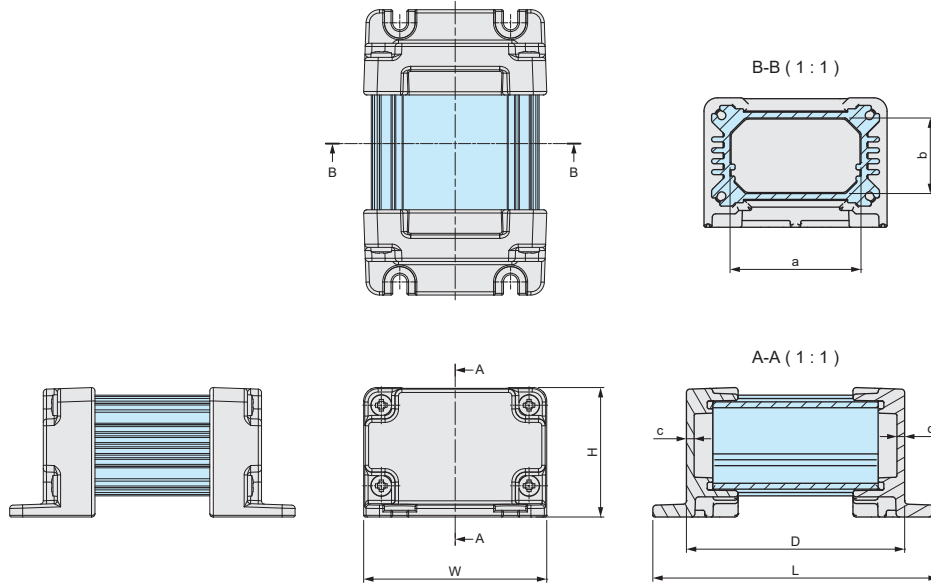

Product no. / Dimensions

■ Please suffix color code at the end of the product number.

Product no.	W	H	D	L	a	b	c	Weight (g)
AW 5-4- 7□□□	54.6	38.6	65	85	39	22.5	2.3	128.5
AW 5-4- 9□□□	54.6	38.6	85	105	39	22.5	2.3	149
AW 5-4-11□□□	54.6	38.6	110	130	39	22.5	2.3	175
AW 5-4-14□□□	54.6	38.6	135	155	39	22.5	2.3	201.5
AW 7-7- 8□□□	65.8	70.8	80	106	47	51	2.5	294.5
AW 7-7-11□□□	65.8	70.8	110	136	47	51	2.5	350
AW 7-7-15□□□	65.8	70.8	150	176	47	51	2.5	424.5
AW 7-7-20□□□	65.8	70.8	200	226	47	51	2.5	517
AW 7-7-25□□□	65.8	70.8	250	276	47	51	2.5	610
AW 8-5- 9□□□	80.8	50.8	90	116	62	31	2.5	289.5
AW 8-5-12□□□	80.8	50.8	115	141	62	31	2.5	330.5
AW 8-5-14□□□	80.8	50.8	140	166	62	31	2.5	372
AW 8-5-18□□□	80.8	50.8	175	201	62	31	2.5	429.5
AW 9-9-10□□□	86.3	92	100	129	66.5	66.5	3	560.5
AW 9-9-13□□□	86.3	92	125	154	66.5	66.5	3	633.5
AW 9-9-17□□□	86.3	92	170	199	66.5	66.5	3	764.5
AW 9-9-22□□□	86.3	92	220	249	66.5	66.5	3	910.5
AW 9-9-28□□□	86.3	92	275	304	66.5	66.5	3	1,071
AW11-6-11□□□	106.3	62	110	139	86.5	36.5	3	526.5
AW11-6-15□□□	106.3	62	150	179	86.5	36.5	3	625
AW11-6-19□□□	106.3	62	190	219	86.5	36.5	3	723.5
AW11-6-24□□□	106.3	62	240	269	86.5	36.5	3	847
AW12-8-11□□□	120	77	105	134	100.2	51.5	3	614.5
AW12-8-14□□□	120	77	140	169	100.2	51.5	3	720.5
AW12-8-17□□□	120	77	179.5	208.5	100.2	51.5	3	840
AW12-8-22□□□	120	77	215	244	100.2	51.5	3	947.5
AW16-9-14□□□	156.3	87	135	164	136.5	61.5	3	945.5
AW16-9-18□□□	156.3	87	175	204	136.5	61.5	3	1,092.5
AW16-9-23□□□	156.3	87	225	254	136.5	61.5	3	1,275.5
AW16-9-28□□□	156.3	87	275	304	136.5	61.5	3	1,459
AW21-9-17□□□	206.3	87	170	199	186.5	61.5	3	1,303
AW21-9-21□□□	206.3	87	210	239	186.5	61.5	3	1,473.5
AW21-9-26□□□	206.3	87	260	289	186.5	61.5	3	1,686.5
AW21-9-31□□□	206.3	87	310	339	186.5	61.5	3	1,899.5

Accessories (Optional parts)



Mounting plate □AWC series
See page 170



Hexagon socket head screw HCS series
See page 170



Cable gland
See cable gland pages



Pole mounting bracket SSK series
See page SSK-M-1 ~ SSK-M-3



Protective vent PMF series
See page PMF-1 ~ PMF-3

AWN SERIES

IP67 HEAT-SINK ALUMINIUM ENCLOSURE



- IP67 and heat dissipation enclosure design. Selectable in both Normal or EMC Shielded type.
- The extruded aluminium frame and diecast aluminium panels makes it extremely suitable to be used in harsh environments where waterproofing and heat dissipation is essential.
- PCB or chassis can be mounted by sliding it horizontally into inner-grooved body frame.
- Suitable for measuring instruments, industrial control box, and industrial camera housing, among others.

Technical Data
Protection class: IP67
Operating temperature: -40°C ~ +105°C
Recommended torque: 1.0N • m (10kgf • cm)

Normal N type Components

No.	Part name	Pcs	Material	Color / Finish
1	End Panel	2	Diecast aluminium ADC12	Metallic gray • Black / Powder coated
2	Body frame	1	Extruded aluminium A6063S-T5	Silver • Black / Anodized
3	Gasket	2	Silicone	Black
4	Screw	8	Stainless steel	Unfinished
5	Rubber feet	4	Polyurethane	Black

EMC Shielded E type Components

No.	Part name	Pcs	Material	Color / Finish
1	End Panel	2	Diecast aluminium ADC12	Silver • Black / Painted (unfinished inside)
2	Body frame	1	Extruded aluminium A6063S-T5	Silver • Black / Anodized
3	Gasket	2	Silicone	Black
4	Screw	8	Stainless steel	Unfinished
5	Rubber feet	4	Polyurethane	Black

Normal - N type

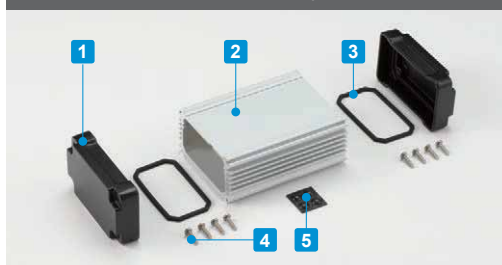

Color type



EMC Shielded - E type

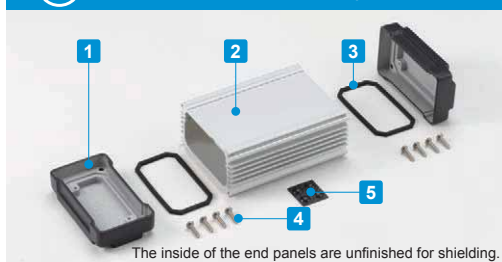

Color type



AWN dimensions

■ Drawings below are reference examples only.
DXF/DWG/PDF drawings available on our website.

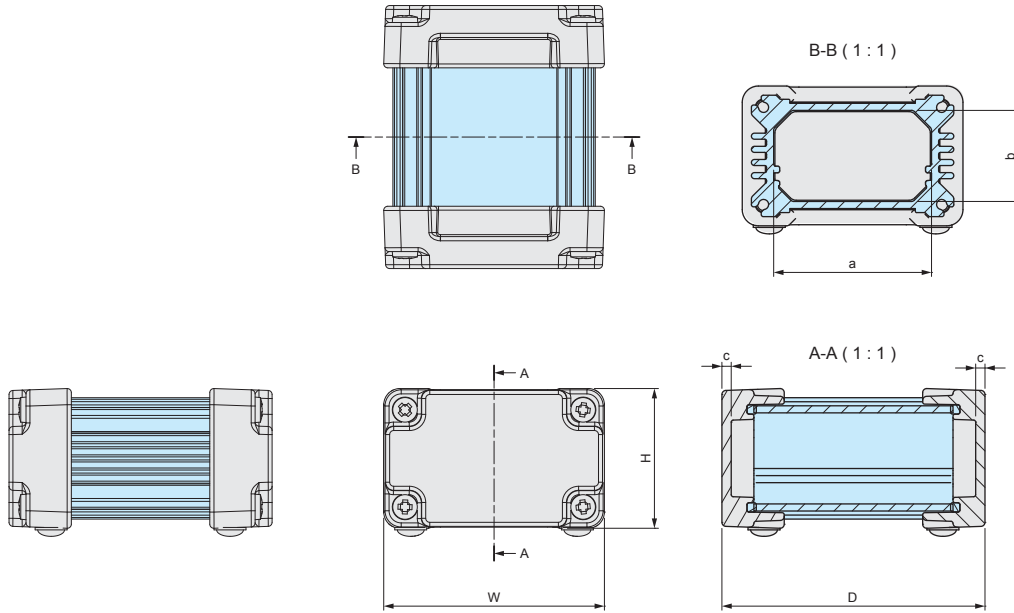

Product no. / Dimensions

■ Please suffix color code at the end of the product number.

Product no.	W	H	D	a	b	c	Weight (g)
AWN 5-4- 7□□□	54.6	34.6	65	39	22.5	2.3	118.5
AWN 5-4- 9□□□	54.6	34.6	85	39	22.5	2.3	139
AWN 5-4-11□□□	54.6	34.6	110	39	22.5	2.3	165
AWN 5-4-14□□□	54.6	34.6	135	39	22.5	2.3	191.5
AWN 7-7- 8□□□	65.8	65.8	80	47	51	2.5	272.5
AWN 7-7-11□□□	65.8	65.8	110	47	51	2.5	328
AWN 7-7-15□□□	65.8	65.8	150	47	51	2.5	402.5
AWN 7-7-20□□□	65.8	65.8	200	47	51	2.5	495
AWN 7-7-25□□□	65.8	65.8	250	47	51	2.5	588
AWN 8-5- 9□□□	80.8	45.8	90	62	31	2.5	259.5
AWN 8-5-12□□□	80.8	45.8	115	62	31	2.5	300.5
AWN 8-5-14□□□	80.8	45.8	140	62	31	2.5	342
AWN 8-5-18□□□	80.8	45.8	175	62	31	2.5	399.5
AWN 9-9-10□□□	86.3	86.3	100	66.5	66.5	3	521.5
AWN 9-9-13□□□	86.3	86.3	125	66.5	66.5	3	594.5
AWN 9-9-17□□□	86.3	86.3	170	66.5	66.5	3	725.5
AWN 9-9-22□□□	86.3	86.3	220	66.5	66.5	3	871.5
AWN 9-9-28□□□	86.3	86.3	275	66.5	66.5	3	1,032
AWN11-6-11□□□	106.3	56.3	110	86.5	36.5	3	479.5
AWN11-6-15□□□	106.3	56.3	150	86.5	36.5	3	578
AWN11-6-19□□□	106.3	56.3	190	86.5	36.5	3	676.5
AWN11-6-24□□□	106.3	56.3	240	86.5	36.5	3	800
AWN12-8-11□□□	120	71.3	105	100.2	51.5	3	590.5
AWN12-8-14□□□	120	71.3	140	100.2	51.5	3	696.5
AWN12-8-17□□□	120	71.3	179.5	100.2	51.5	3	816
AWN12-8-22□□□	120	71.3	215	100.2	51.5	3	923.5
AWN16-9-14□□□	156.3	81.3	135	136.5	61.5	3	871.5
AWN16-9-18□□□	156.3	81.3	175	136.5	61.5	3	1,018.5
AWN16-9-23□□□	156.3	81.3	225	136.5	61.5	3	1,201.5
AWN16-9-28□□□	156.3	81.3	275	136.5	61.5	3	1,385
AWN21-9-17□□□	206.3	81.3	170	186.5	61.5	3	1,261
AWN21-9-21□□□	206.3	81.3	210	186.5	61.5	3	1,431.5
AWN21-9-26□□□	206.3	81.3	260	186.5	61.5	3	1,644.5
AWN21-9-31□□□	206.3	81.3	310	186.5	61.5	3	1,857.5

Accessories (Optional parts)



Mounting plate AWC series
See page 170



Hexagon socket head screw HCS series
See page 170



Cable gland
See cable gland pages



Silicone protector AWSP series
See page 169

AWP SERIES

IP67 ALUMINIUM ENCLOSURE with SILICONE PROTECTOR



Technical Data
Protection class: IP67
Operating temperature: -40°C ~ +105°C
Recommended torque: 1.0N • m (10kgf • cm)

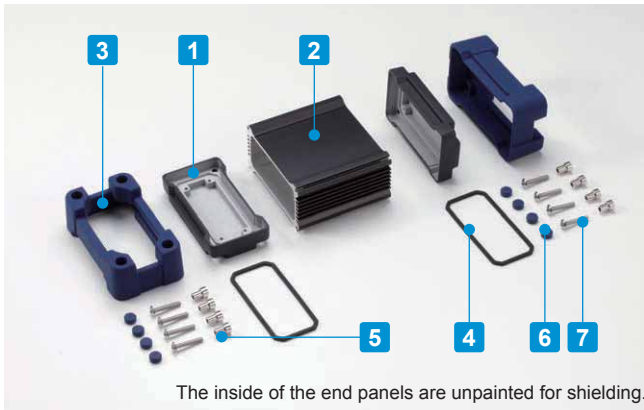

- Strong impact resistant enclosure with tough silicone boot protectors.
- Specifically designed with heat dissipation effect, EMC shielding and IP67 rating.
- PCB or chassis can be horizontally mounted by sliding into an inner-grooved body frame.
- Available in 30 sizes and 8 different color combinations. Selectable from a total of 240 different combinations.
- Suitable for measuring instruments, industrial control box, industrial camera housing, etc.

Components

No.	Part name	Pcs	Material	Color / Finish
1	End panel	2	Diecast aluminium ADC12	Silver • Black / Painted (unfinished inside)
2	Body frame	1	Extruded aluminium A6063S-T5	Siver • Black / Anodized
3	Protector	2	Silicone	Black • Gray • Navy • Yellow
4	Conductive gasket	2	Conductive silicone	Black
5	Spacer	8	Brass	Nickel plated
6	Blind cap	8	Silicone	Black • Gray • Navy • Yellow
7	Screw	8	Stainless steel	Unfinished

Color Type



Ordering Number

For example, in case of ordering AWP7-7-8 size, Black enclosure and Navy silicone protector.

Product no. : AWP7-7-8

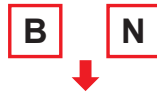

Put a color code SB, SG, SN, SY, BB, BG, BN or BY.

- ※ Thermal resistance test condition
- Ambient air cooling
- Heat-sink fins are set perpendicular to the ground with temperature at 60°C.
- Anodized aluminium extrusion
- Heat source is applied on the opposite side (inner side) of the fins.

Product no. / Dimensions

Product no.	W	H	D	※Thermal resistance rate (°C/W)	Weight (g)
AWP 7-7- 8□□	72.4(65.8)	73.6(65.8)	104 (80)	4.41	363.5
AWP 7-7-11□□	72.4(65.8)	73.6(65.8)	134(110)	3.5	419
AWP 7-7-15□□	72.4(65.8)	73.6(65.8)	174(150)	2.83	493.5
AWP 7-7-20□□	72.4(65.8)	73.6(65.8)	224(200)	2.33	586
AWP 7-7-25□□	72.4(65.8)	73.6(65.8)	274(250)	2.02	679
AWP 8-5- 9□□	87.4(80.8)	53.6(45.8)	114 (90)	5.97	353.5
AWP 8-5-12□□	87.4(80.8)	53.6(45.8)	139(115)	5.01	394.5
AWP 8-5-14□□	87.4(80.8)	53.6(45.8)	164(140)	4.37	436
AWP 8-5-18□□	87.4(80.8)	53.6(45.8)	199(175)	3.76	493.5
AWP 9-9-10□□	93.9(86.3)	95.1(86.3)	130(100)	3.1	693
AWP 9-9-13□□	93.9(86.3)	95.1(86.3)	155(125)	2.63	766
AWP 9-9-17□□	93.9(86.3)	95.1(86.3)	200(170)	2.12	897
AWP 9-9-22□□	93.9(86.3)	95.1(86.3)	250(220)	1.79	1,043
AWP 9-9-28□□	93.9(86.3)	95.1(86.3)	305(275)	1.54	1,203.5
AWP11-6-11□□	113.9(106.3)	65.1(56.3)	140(110)	4.52	652.5
AWP11-6-15□□	113.9(106.3)	65.1(56.3)	180(150)	3.62	751.5
AWP11-6-19□□	113.9(106.3)	65.1(56.3)	220(190)	3.08	850
AWP11-6-24□□	113.9(106.3)	65.1(56.3)	270(240)	2.64	973
AWP12-8-11□□	127.6(120)	80.1(71.3)	135(105)	3.6	778.5
AWP12-8-14□□	127.6(120)	80.1(71.3)	170(140)	2.93	885
AWP12-8-17□□	127.6(120)	80.1(71.3)	209.5(179.5)	2.47	1,004.5
AWP12-8-22□□	127.6(120)	80.1(71.3)	245(215)	2.18	1,112
AWP16-9-14□□	163.9(156.3)	90.1(81.3)	165(135)	2.64	1,094
AWP16-9-18□□	163.9(156.3)	90.1(81.3)	205(175)	2.2	1,240.5
AWP16-9-23□□	163.9(156.3)	90.1(81.3)	255(225)	1.86	1,424
AWP16-9-28□□	163.9(156.3)	90.1(81.3)	305(275)	1.63	1,607.5
AWP21-9-17□□	213.9(206.3)	90.1(81.3)	202(170)	2.3	1,571.5
AWP21-9-21□□	213.9(206.3)	90.1(81.3)	242(210)	1.99	1,742
AWP21-9-26□□	213.9(206.3)	90.1(81.3)	292(260)	1.72	1,955.5
AWP21-9-31□□	213.9(206.3)	90.1(81.3)	342(310)	1.54	2,168.5

■ () value = enclosure dimension.

AWP dimensions

■ DXF/DWG/PDF drawings available on our website.

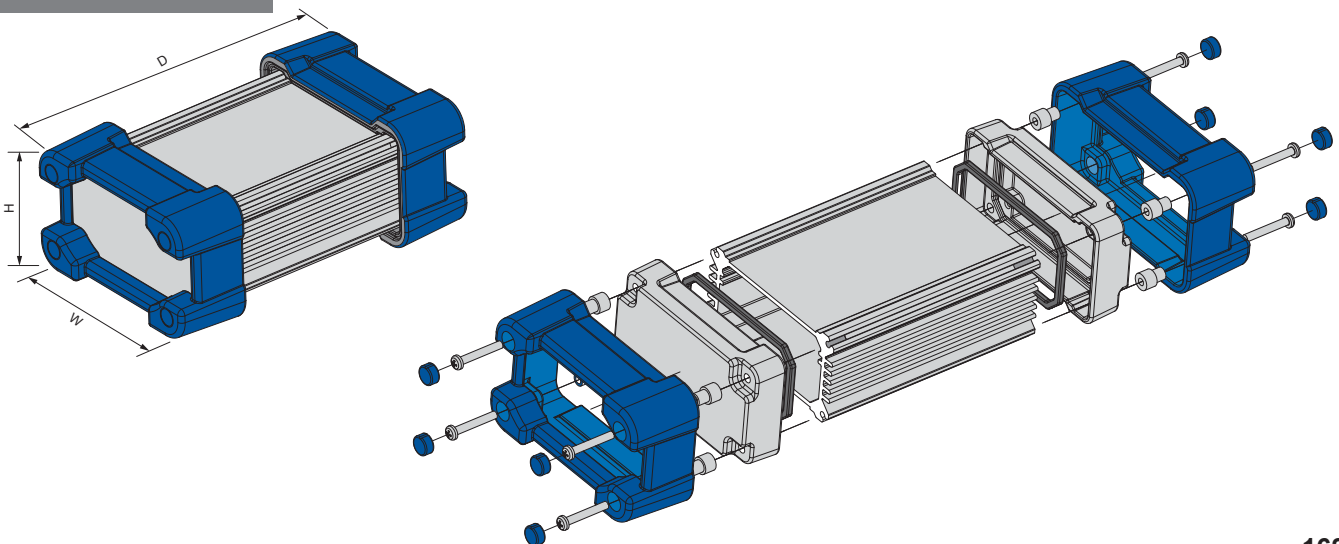

AW • AWN • AWP • AWA frame

■ Drawings below are reference examples only.
DXF/DWG/PDF drawings available on our website.

AW/AWN5-4-□
AWA5-3-□

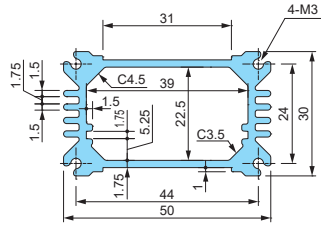

AW/AWN/AWP7-7-□
AWA6-6-□

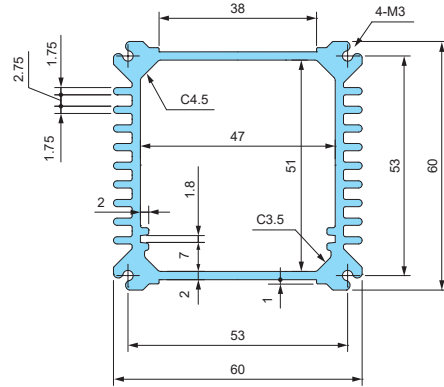

AW/AWN/AWP8-5-□
AWA8-4-□

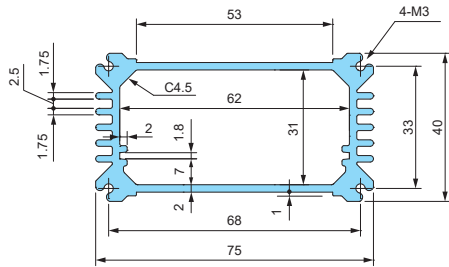

AW/AWN/AWP9-9-□
AWA8-8-□

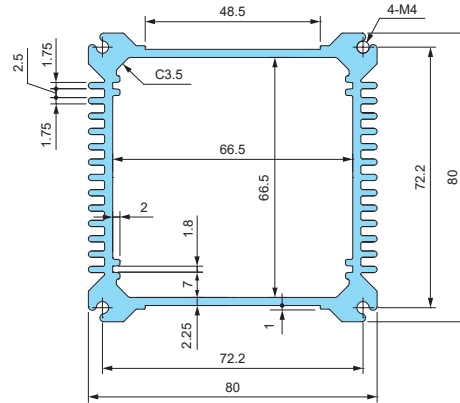

AW/AWN/AWP11-6-□
AWA10-5-□

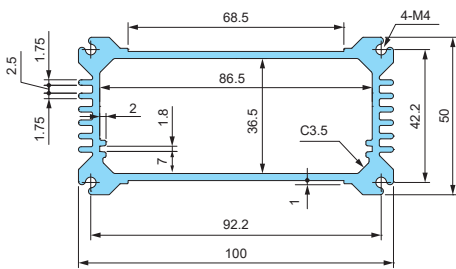

AW/AWN/AWP12-8-□
AWA12-7-□

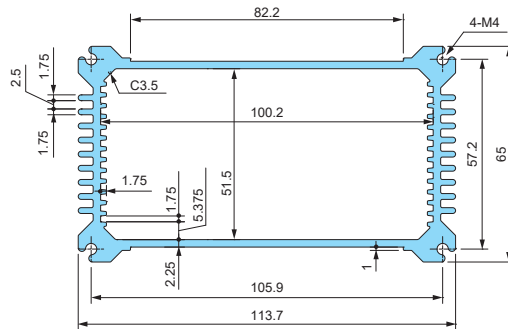

AW/AWN/AWP16-9-□
AWA15-8-□

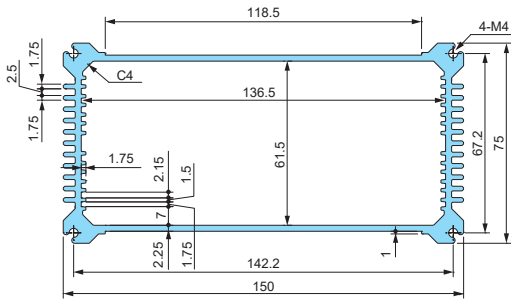

AW/AWN/AWP21-9-□
AWA20-8-□

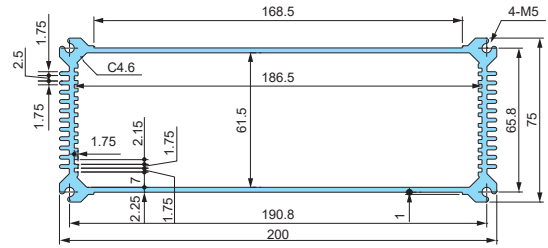

- ※ Thermal resistance test condition
- Ambient air cooling
 - Heat-sink fins are set perpendicular to the ground with temperature at 60°C.
 - Anodized aluminium extrusion
 - Heat source is applied on the opposite side (inner side) of the fins.

Product no.				Frame	※Thermal resistance rate (°C/W)
AW 5-4- 7	AWN 5-4- 7	—	AWA 5-3- 5	49.2	11.2
AW 5-4- 9	AWN 5-4- 9	—	AWA 5-3- 7	69.2	9.18
AW 5-4-11	AWN 5-4-11	—	AWA 5-3-10	94.2	7.64
AW 5-4-14	AWN 5-4-14	—	AWA 5-3-12	119.2	6.63
AW 7-7- 8	AWN 7-7- 8	AWP 7-7- 8	AWA 6-6- 7	64	4.41
AW 7-7-11	AWN 7-7-11	AWP 7-7-11	AWA 6-6-10	94	3.5
AW 7-7-15	AWN 7-7-15	AWP 7-7-15	AWA 6-6-14	134	2.83
AW 7-7-20	AWN 7-7-20	AWP 7-7-20	AWA 6-6-19	184	2.33
AW 7-7-25	AWN 7-7-25	AWP 7-7-25	AWA 6-6-24	234	2.02
AW 8-5- 9	AWN 8-5- 9	AWP 8-5- 9	AWA 8-4- 8	74	5.97
AW 8-5-12	AWN 8-5-12	AWP 8-5-12	AWA 8-4-10	99	5.01
AW 8-5-14	AWN 8-5-14	AWP 8-5-14	AWA 8-4-13	124	4.37
AW 8-5-18	AWN 8-5-18	AWP 8-5-18	AWA 8-4-16	159	3.76
AW 9-9-10	AWN 9-9-10	AWP 9-9-10	AWA 8-8- 9	81	3.1
AW 9-9-13	AWN 9-9-13	AWP 9-9-13	AWA 8-8-11	106	2.63
AW 9-9-17	AWN 9-9-17	AWP 9-9-17	AWA 8-8-16	151	2.12
AW 9-9-22	AWN 9-9-22	AWP 9-9-22	AWA 8-8-21	201	1.79
AW 9-9-28	AWN 9-9-28	AWP 9-9-28	AWA 8-8-26	256	1.54
AW11-6-11	AWN11-6-11	AWP11-6-11	AWA10-5-10	90.6	4.52
AW11-6-15	AWN11-6-15	AWP11-6-15	AWA10-5-14	130.6	3.62
AW11-6-19	AWN11-6-19	AWP11-6-19	AWA10-5-18	170.6	3.08
AW11-6-24	AWN11-6-24	AWP11-6-24	AWA10-5-23	220.6	2.64
AW12-8-11	AWN12-8-11	AWP12-8-11	AWA12-7- 9	85.6	3.6
AW12-8-14	AWN12-8-14	AWP12-8-14	AWA12-7-12	120.6	2.93
AW12-8-17	AWN12-8-17	AWP12-8-17	AWA12-7-17	160.1	2.47
AW12-8-22	AWN12-8-22	AWP12-8-22	AWA12-7-20	195.6	2.18
AW16-9-14	AWN16-9-14	AWP16-9-14	AWA15-5-12	115.6	2.64
AW16-9-18	AWN16-9-18	AWP16-9-18	AWA15-8-16	155.6	2.2
AW16-9-23	AWN16-9-23	AWP16-9-23	AWA15-8-21	205.6	1.86
AW16-9-28	AWN16-9-28	AWP16-9-28	AWA15-8-26	255.6	1.63
AW21-9-17	AWN21-9-17	AWP21-9-17	AWA20-8-15	147.8	2.3
AW21-9-21	AWN21-9-21	AWP21-9-21	AWA20-8-19	187.8	1.99
AW21-9-26	AWN21-9-26	AWP21-9-26	AWA20-8-24	237.8	1.72
AW21-9-31	AWN21-9-31	AWP21-9-31	AWA20-8-29	287.8	1.54

AWSP SERIES

SILICONE PROTECTOR

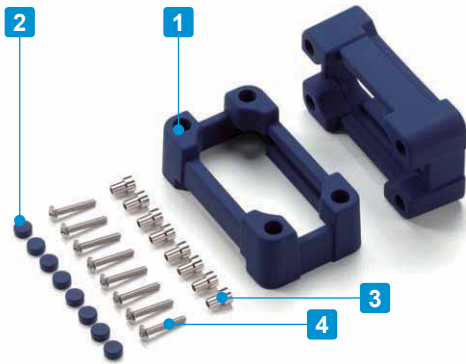

Color Type

Code	B Black	G Gray	N Navy	Y Yellow
Color				

- Silicone protector for AWN series.
- Protect switches and/or connectors on end panels from impact when dropped, etc.

AWSP dimensions

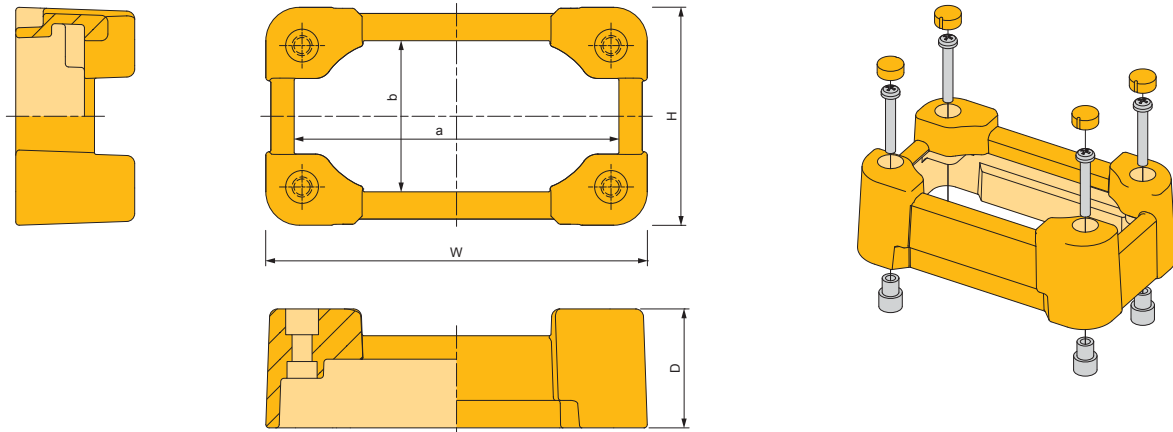

Components

No.	Part name	Pcs	Material	Color / Finish
1	Protector	2	Silicone	Black • Gray • Navy • Yellow
2	Blind cap	8	Silicone	Black • Gray • Navy • Yellow
3	Spacer	8	Brass	Nickel plated
4	Screw	8	Stainless steel	Unfinished

Product no. / Dimensions

■ Please suffix color code at the end of the product number.

Product no.	W	H	D	a	b	Screw size	Suitable enclosure	Weight (g)
AWSP 7-7□	72.4	73.6	31	58.4	56.6	M3	AWN 7-7-□	99
AWSP 8-5□	87.4	53.6	31	73.4	36.6	M3	AWN 8-5-□	100.5
AWSP 9-9□	93.9	95.1	35.5	76.9	75.1	M4	AWN 9-9-□	184.5
AWSP11-6□	113.9	65.1	35.5	96.9	45.1	M4	AWN11-6-□	186
AWSP12-8□	127.6	80.1	35.5	110.6	60.1	M4	AWN12-8-□	201
AWSP16-9□	163.9	90.1	35.5	145.9	69.1	M4	AWN16-9-□	235
AWSP21-9□	213.9	90.1	39.5	192.9	66.1	M5	AWN21-9-□	333

AWC SERIES

ALUMINIUM MOUNTING PLATE

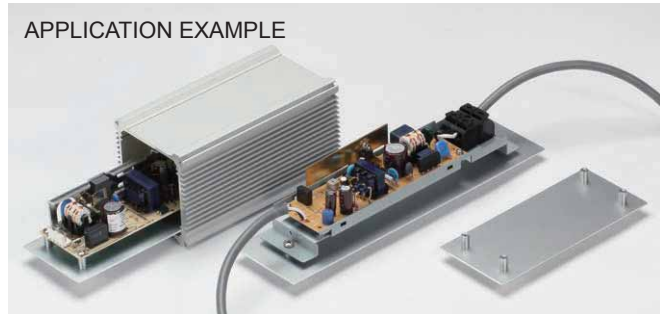
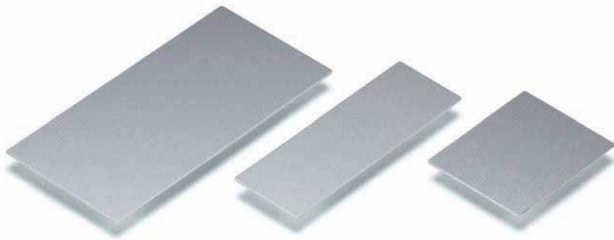

- Material: Aluminium A1050P t=1.5 / Silver anodized
- Mounting plate for AW, AWN, AWP, and AWA series enclosures.
- Utilize for mounting PCB, power supply, terminal blocks, etc.

■ DXF/DWG/PDF drawings available on our website.

Product no. / Dimensions

Product no.	W	D	Suitable enclosure
AWC 5- 7	38.9	49.2	AW • AWN 5-4-7 • AWA 5-3-5
AWC 5- 9	38.9	69.2	AW • AWN 5-4-9 • AWA 5-3-7
AWC 5-11	38.9	94.2	AW • AWN 5-4-11 • AWA 5-3-10
AWC 5-14	38.9	119.2	AW • AWN 5-4-14 • AWA 5-3-12
AWC 7- 8	47	64	AW • AWN • AWP 7-7-8 • AWA 6-6- 7
AWC 7-11	47	94	AW • AWN • AWP 7-7-11 • AWA 6-6-10
AWC 7-15	47	134	AW • AWN • AWP 7-7-15 • AWA 6-6-14
AWC 7-20	47	184	AW • AWN • AWP 7-7-20 • AWA 6-6-19
AWC 7-25	47	234	AW • AWN • AWP 7-7-25 • AWA 6-6-24
AWC 8- 9	61.8	74	AW • AWN • AWP 8-5-9 • AWA 8-4-8
AWC 8-12	61.8	99	AW • AWN • AWP 8-5-12 • AWA 8-4-10
AWC 8-14	61.8	124	AW • AWN • AWP 8-5-14 • AWA 8-4-13
AWC 8-18	61.8	159	AW • AWN • AWP 8-5-18 • AWA 8-4-16
AWC 9-10	66.5	81	AW • AWN • AWP 9-9-10 • AWA 8-8-9
AWC 9-13	66.5	106	AW • AWN • AWP 9-9-13 • AWA 8-8-11
AWC 9-17	66.5	151	AW • AWN • AWP 9-9-17 • AWA 8-8-16
AWC 9-22	66.5	201	AW • AWN • AWP 9-9-22 • AWA 8-8-21
AWC 9-28	66.5	256	AW • AWN • AWP 9-9-28 • AWA 8-8-26
AWC11-11	86.5	90.6	AW • AWN • AWP11-6-11 • AWA10-5-10
AWC11-15	86.5	130.6	AW • AWN • AWP11-6-15 • AWA10-5-14
AWC11-19	86.5	170.6	AW • AWN • AWP11-6-19 • AWA10-5-18
AWC11-24	86.5	220.6	AW • AWN • AWP11-6-24 • AWA10-5-23
AWC12-11	100.2	85.6	AW • AWN • AWP12-8-11 • AWA12-7-9
AWC12-14	100.2	120.6	AW • AWN • AWP12-8-14 • AWA12-7-12
AWC12-17	100.2	160.1	AW • AWN • AWP12-8-17 • AWA12-7-17
AWC12-22	100.2	195.6	AW • AWN • AWP12-8-22 • AWA12-7-20
AWC16-14	136.3	115.6	AW • AWN • AWP16-9-14 • AWA15-8-12
AWC16-18	136.3	155.6	AW • AWN • AWP16-9-18 • AWA15-8-16
AWC16-23	136.3	205.6	AW • AWN • AWP16-9-23 • AWA15-8-21
AWC16-28	136.3	255.6	AW • AWN • AWP16-9-28 • AWA15-8-26
AWC21-17	186.1	147.8	AW • AWN • AWP21-9-17 • AWA20-8-15
AWC21-21	186.1	187.8	AW • AWN • AWP21-9-21 • AWA20-8-19
AWC21-26	186.1	237.8	AW • AWN • AWP21-9-26 • AWA20-8-24
AWC21-31	186.1	287.8	AW • AWN • AWP21-9-31 • AWA20-8-29

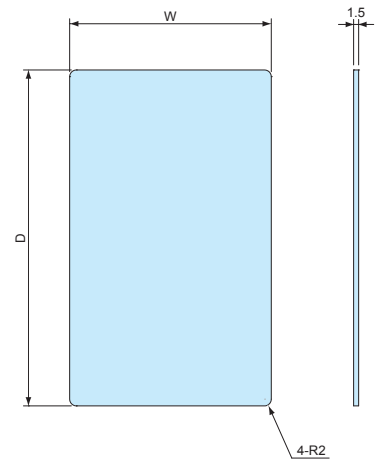

HCS SERIES

HEXAGON SOCKET HEAD SCREW

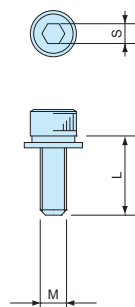

- Hexagon socket head screws for fastening the end panels of AW and AWN enclosures.
- Utilize for tamper-resistance functionality or for an elegant sleek look.

Product no. / Dimensions

Product no.	M	L	S	Material	Pack of
HCS3-12S	3	12	2.5	Stainless steel	8
HCS4-12S	4	12	3	Stainless steel	8
HCS5-12S	5	12	4	Stainless steel	8

EXW SERIES

IP65 ALUMINIUM CASE with CORNER GUARD



- IP65 is made possible by the sealing of between top & bottom covers and end panels with gaskets.
- Available in 39 different sizes and 6 different color combinations by 2 body frame and 3 end panel colors.
- Custom length is available.

Technical Data
Protection class : IP65

Included screw
 EXW7-□, 9-□ models : M2.5-8 x 8 pcs
 EXW12-□, 15-□ models : M3-10 x 8 pcs
 ※Hexagonal wrench included.

Components

No.	Part name	Pcs	Material	Color / Finish
1	End panel	2	PC+ABS UL94V-0	Black • Gray / Unpainted Navy / Painted
2	Top cover	1	Extruded aluminium A6063S-T5	Silver • Black / Anodized
3	Bottom cover	1	Extruded aluminium A6063S-T5	Silver • Black / Anodized
4	Panel gasket	2	Silicone	Black • Dark gray
5	Cover gasket	2	Silicone	White gray
6	Screw	8	Stainless Steel	Unfinished

Color Type

Code	S B Silver / Black	S G Silver / Gray	S N Silver / Navy
Color			
Code	B B Black / Black	B G Black / Gray	B N Black / Navy
Color			

■ DXF/DWG/PDF drawings available on our website.

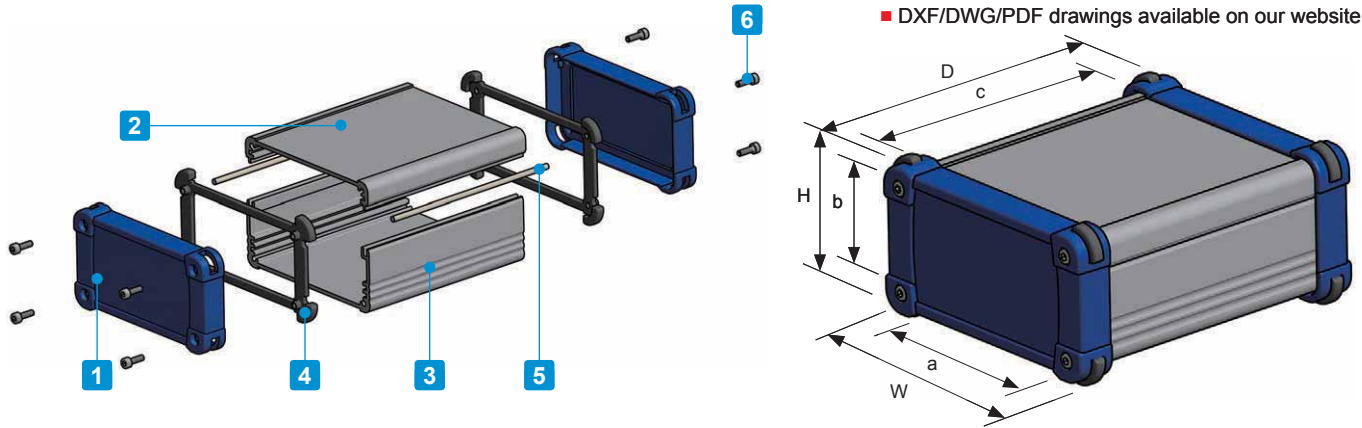

■ Please suffix color code at the end of the product number.

Product no. / Dimensions

Product no.	External dimensions			Internal dimensions		
	W	H	D	a	b	c
EXW 7- 3- 6□□	69	34	58	47	20	46
EXW 7- 3- 9□□	69	34	85	47	20	73
EXW 7- 3-11□□	69	34	108	47	20	96
EXW 7- 4- 6□□	69	44	58	47	30	46
EXW 7- 4- 9□□	69	44	85	47	30	73
EXW 7- 4-11□□	69	44	108	47	30	96
EXW 7- 6- 6□□	69	59	58	47	45	46
EXW 7- 6- 9□□	69	59	85	47	45	73
EXW 7- 6-11□□	69	59	108	47	45	96
EXW 9- 4- 7□□	89	39	69	67	25	56
EXW 9- 4-10□□	89	39	99	67	25	86
EXW 9- 4-13□□	89	39	129	67	25	116
EXW 9- 5- 7□□	89	49	69	67	35	56
EXW 9- 5-10□□	89	49	99	67	35	86
EXW 9- 5-13□□	89	49	129	67	35	116
EXW 9- 6- 7□□	89	64	69	67	50	56
EXW 9- 6-10□□	89	64	99	67	50	86
EXW 9- 6-13□□	89	64	129	67	50	116
EXW12- 4- 9□□	116	41	88	89	24	74
EXW12- 4-13□□	116	41	128	89	24	114
EXW12- 4-18□□	116	41	174	89	24	160
EXW12- 6- 9□□	116	56	88	89	39	74
EXW12- 6-13□□	116	56	128	89	39	114
EXW12- 6-18□□	116	56	174	89	39	160
EXW12- 7- 9□□	116	71	88	89	54	74
EXW12- 7-13□□	116	71	128	89	54	114
EXW12- 7-18□□	116	71	174	89	54	160
EXW15- 5-11□□	151	46	107	107	29	93
EXW15- 5-15□□	151	46	147	107	29	133
EXW15- 5-20□□	151	46	197	107	29	183
EXW15- 6-11□□	151	61	107	107	44	93
EXW15- 6-15□□	151	61	147	107	44	133
EXW15- 6-20□□	151	61	197	107	44	183
EXW15- 8-11□□	151	81	107	107	64	93
EXW15- 8-15□□	151	81	147	107	64	133
EXW15- 8-20□□	151	81	197	107	64	183
EXW15-10-11□□	151	101	107	107	84	93
EXW15-10-15□□	151	101	147	107	84	133
EXW15-10-20□□	151	101	197	107	84	183

■ Custom length is available.

How to install cover gasket



■ Insert cover gaskets into the joint-grooves on the bottom cover.



■ Ensure that a small portion of the cover gasket protrudes out in order to maintain a seal with the panel gasket.

EXWF SERIES

IP65 FLANGED ALUMINIUM CASE



- Waterproof case available in 67 different sizes and 6 different color combinations by 2 body frame and 3 end panel colors.
- Flanged end panels make it easy for wall mounting. Suitable to be used as wall mounted controller and transmitter.
- Custom length is available.

Technical Data
Protection class : IP65 • IP54
Protection class varies by size.
■ Not suitable for environments with direct rainfall

Included screw
 EXWF7-□, 9-□ models : M2.5-8 x 8 pcs
 EXWF12-□, 15-□ models : M3-10 x 8 pcs
 EXWF20-□ models : M4-12 x 8 pcs
 EXWF24-□ models : M5-12 x 8 pcs
 ※Hexagonal wrench included.

Components

No.	Part name	Pcs	Material	Color / Finish
1	Flanged end panel	2	PC+ABS UL94V-0	Black • Gray / Unpainted Navy / Painted
2	Top cover	1	Extruded aluminium A6063S-T5	Silver • Black / Anodized
3	Bottom cover	1	Extruded aluminium A6063S-T5	Silver • Black / Anodized
4	Panel gasket	2	Silicone	Black
5	Cover gasket	2	Silicone	White gray
6	Screw	8	Stainless Steel	Unfinished

Color Type

Code	S B Silver / Black	S G Silver / Gray	S N Silver / Navy
Color			
Code	B B Black / Black	B G Black / Gray	B N Black / Navy
Color			

DXF/DWG/PDF drawings available on our website.

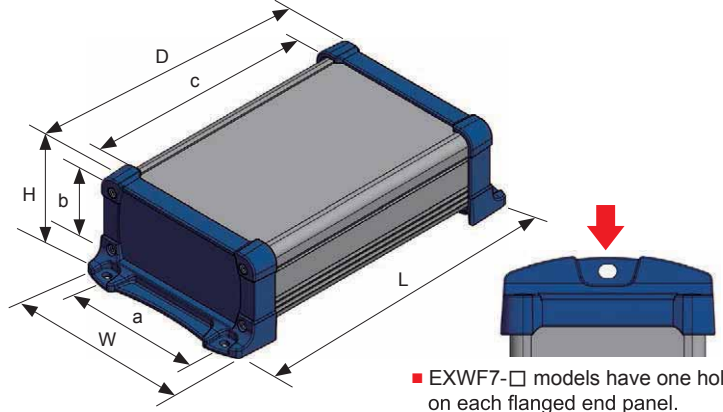
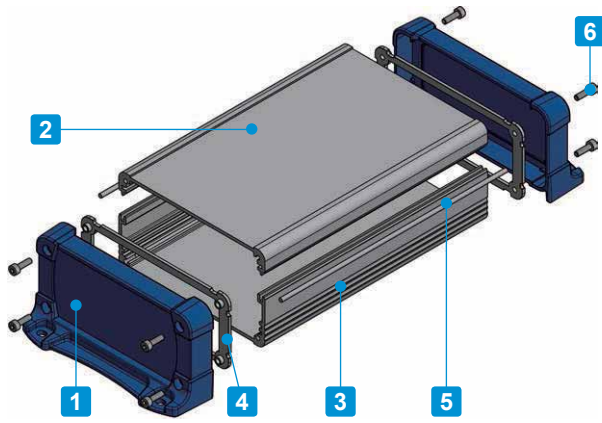

EXWF7-□ models have one hole on each flanged end panel.

Please suffix color code at the end of the product number.

Product no. / Dimensions

Product no.	Protection class	External dimensions				Internal dimensions		
		W	H	D	L	a	b	c
NEW EXWF 7- 3- 6□□	IP65	66	34	58	82	47	20	46
NEW EXWF 7- 3- 9□□	IP65	66	34	85	109	47	20	73
NEW EXWF 7- 3-11□□	IP65	66	34	108	132	47	20	96
NEW EXWF 7- 4- 6□□	IP65	66	44	58	82	47	30	46
NEW EXWF 7- 4- 9□□	IP65	66	44	85	109	47	30	73
NEW EXWF 7- 4-11□□	IP65	66	44	108	132	47	30	96
NEW EXWF 7- 6- 6□□	IP65	66	59	58	82	47	45	46
NEW EXWF 7- 6- 9□□	IP65	66	59	85	109	47	45	73
NEW EXWF 7- 6-11□□	IP65	66	59	108	132	47	45	96
NEW EXWF 9- 4- 7□□	IP65	86	39	69	94.8	67	25	56
NEW EXWF 9- 4-10□□	IP65	86	39	99	124.8	67	25	86
NEW EXWF 9- 4-13□□	IP65	86	39	129	154.8	67	25	116
NEW EXWF 9- 5- 7□□	IP65	86	49	69	94.8	67	35	56
NEW EXWF 9- 5-10□□	IP65	86	49	99	124.8	67	35	86
NEW EXWF 9- 5-13□□	IP65	86	49	129	154.8	67	35	116
NEW EXWF 9- 6- 7□□	IP65	86	64	69	94.8	67	50	56
NEW EXWF 9- 6-10□□	IP65	86	64	99	124.8	67	50	86
NEW EXWF 9- 6-13□□	IP65	86	64	129	154.8	67	50	116
NEW EXWF11- 4- 9□□	IP65	113	41.5	88	119.8	89	24	74
NEW EXWF11- 4-13□□	IP65	113	41.5	128	159.8	89	24	114
NEW EXWF11- 4-17□□	IP65	113	41.5	174	205.8	89	24	160
NEW EXWF11- 6- 9□□	IP65	113	56.5	88	119.8	89	39	74
NEW EXWF11- 6-13□□	IP65	113	56.5	128	159.8	89	39	114
NEW EXWF11- 6-17□□	IP65	113	56.5	174	205.8	89	39	160
NEW EXWF11- 7- 9□□	IP65	113	71.5	88	119.8	89	54	74
NEW EXWF11- 7-13□□	IP65	113	71.5	128	159.8	89	54	114
NEW EXWF11- 7-17□□	IP65	113	71.5	174	205.8	89	54	160
NEW EXWF15- 5-11□□	IP65	148	47	107	146.2	107	29	93
NEW EXWF15- 5-15□□	IP65	148	47	147	186.2	107	29	133
NEW EXWF15- 5-20□□	IP65	148	47	197	236.2	107	29	183
NEW EXWF15- 6-11□□	IP65	148	62	107	146.2	107	44	93
NEW EXWF15- 6-15□□	IP65	148	62	147	186.2	107	44	133
NEW EXWF15- 6-20□□	IP65	148	62	197	236.2	107	44	183
NEW EXWF15- 8-11□□	IP65	148	82	107	146.2	107	64	93
NEW EXWF15- 8-15□□	IP65	148	82	147	186.2	107	64	133
NEW EXWF15- 8-20□□	IP65	148	82	197	236.2	107	64	183
NEW EXWF15-10-11□□	IP65	148	102	107	146.2	107	84	93
NEW EXWF15-10-15□□	IP65	148	102	147	186.2	107	84	133
NEW EXWF15-10-20□□	IP65	148	102	197	236.2	107	84	183

Product no.	Protection class	External dimensions				Internal dimensions		
		W	H	D	L	a	b	c
NEW EXWF20- 6-14□□	IP54	195	57	138	186.6	132	35	120
NEW EXWF20- 6-19□□	IP54	195	57	190	238.6	132	35	172
NEW EXWF20- 6-25□□	IP54	195	57	243	291.6	132	35	225
NEW EXWF20- 6-30□□	IP54	195	57	298	346.6	132	35	280
NEW EXWF20- 8-14□□	IP54	195	75	138	186.6	132	53	120
NEW EXWF20- 8-19□□	IP54	195	75	190	238.6	132	53	172
NEW EXWF20- 8-25□□	IP54	195	75	243	291.6	132	53	225
NEW EXWF20- 8-30□□	IP54	195	75	298	346.6	132	53	280
NEW EXWF20-10-14□□	IP54	195	95	138	186.6	132	73	120
NEW EXWF20-10-19□□	IP54	195	95	190	238.6	132	73	172
NEW EXWF20-10-25□□	IP54	195	95	243	291.6	132	73	225
NEW EXWF20-10-30□□	IP54	195	95	298	346.6	132	73	280
NEW EXWF20-12-14□□	IP54	195	120	138	186.6	132	98	120
NEW EXWF20-12-19□□	IP54	195	120	190	238.6	132	98	172
NEW EXWF20-12-25□□	IP54	195	120	243	291.6	132	98	225
NEW EXWF20-12-30□□	IP54	195	120	298	346.6	132	98	280
NEW EXWF24- 7-17□□	IP54	240	65	165	213.6	177	43	147
NEW EXWF24- 7-23□□	IP54	240	65	225	273.6	177	43	207
NEW EXWF24- 7-29□□	IP54	240	65	285	333.6	177	43	267
NEW EXWF24- 7-35□□	IP54	240	65	345	393.6	177	43	327
NEW EXWF24- 9-17□□	IP54	240	90	165	213.6	177	68	147
NEW EXWF24- 9-23□□	IP54	240	90	225	273.6	177	68	207
NEW EXWF24- 9-29□□	IP54	240	90	285	333.6	177	68	267
NEW EXWF24- 9-35□□	IP54	240	90	345	393.6	177	68	327
NEW EXWF24-12-17□□	IP54	240	115	165	213.6	177	93	147
NEW EXWF24-12-23□□	IP54	240	115	225	273.6	177	93	207
NEW EXWF24-12-29□□	IP54	240	115	285	333.6	177	93	267
NEW EXWF24-12-35□□	IP54	240	115	345	393.6	177	93	327

How to install cover gasket



Insert cover gaskets into the joint-grooves on the bottom cover.

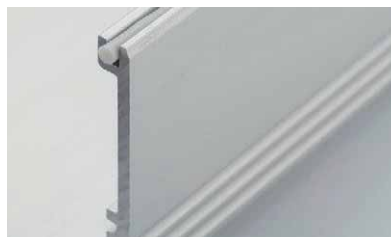

Ensure that a small portion of the cover gasket protrudes out in order to maintain a seal with the panel gasket.

EXP • EXPE • EXW • EXPF • EXEF • EXWF • EX top / bottom covers

■ Drawings below are reference examples only.
DXF/DWG/PDF drawings available on our website.

EXP • EXPE • EXW • EXPF • EXEF • EXWF7-4-□
EX6-3-□

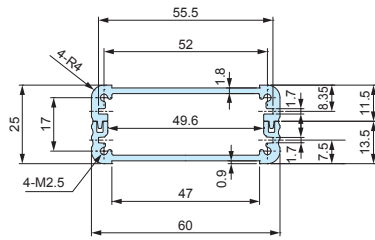

EXP • EXPE • EXW • EXPF • EXEF • EXWF7-4-□
EX6-4-□

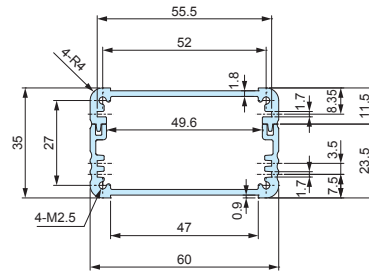

EXP • EXPE • EXW • EXPF • EXEF • EXWF7-6-□
EX6-5-□

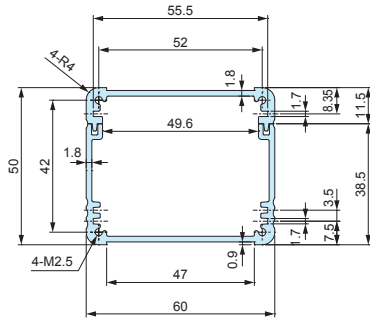

EXP • EXPE • EXW • EXPF • EXEF • EXWF9-4-□
EX8-3-□

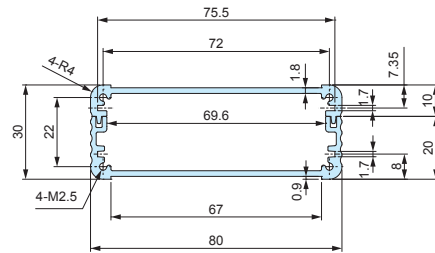

EXP • EXPE • EXW • EXPF • EXEF • EXWF9-5-□
EX8-4-□

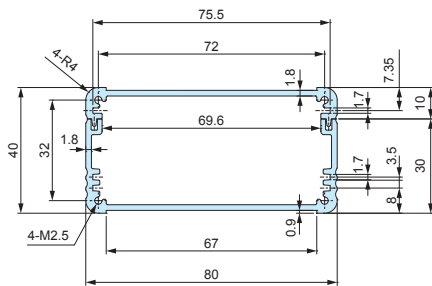

EXP • EXPE • EXW • EXPF • EXEF • EXWF9-6-□
EX8-6-□

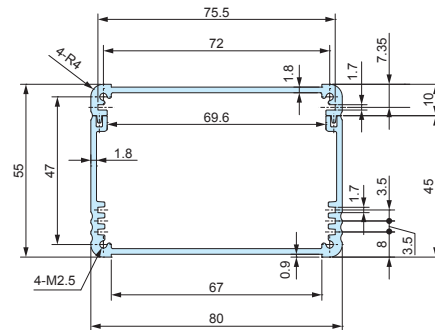

EXP • EXPE • EXW12-4-□
EXPF • EXEF • EXWF11-4-□
EX11-3-□

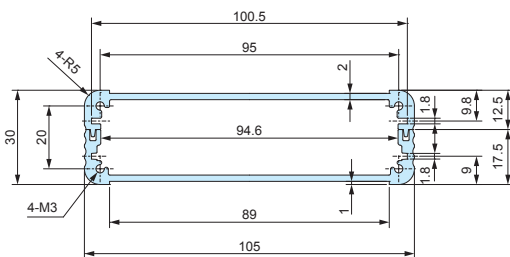

EXP • EXPE • EXW12-6-□
EXPF • EXEF • EXWF11-6-□
EX11-5-□

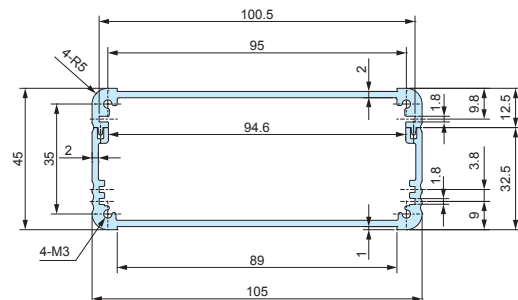

EXP • EXPE • EXW • EXPF • EXEF • EXWF • EX top / bottom covers

■ Drawings below are reference examples only.
DXF/DWG/PDF drawings available on our website.

EXP • EXPE • EXW12-7-□
EXPF • EXEF • EXWF11-7-□
EX11-6-□

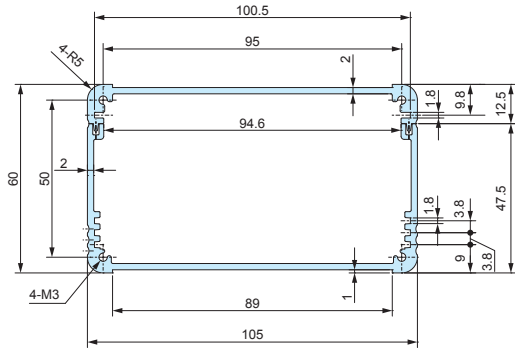

EXP • EXPE • EXW • EXPF • EXEF • EXWF15-5-□
EX14-4-□

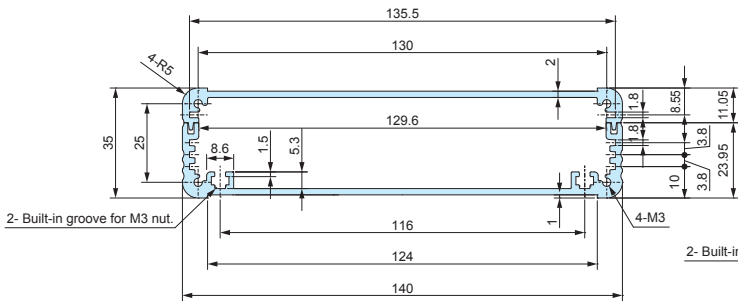

EXP • EXPE • EXW • EXPF • EXEF • EXWF15-6-□
EX14-5-□

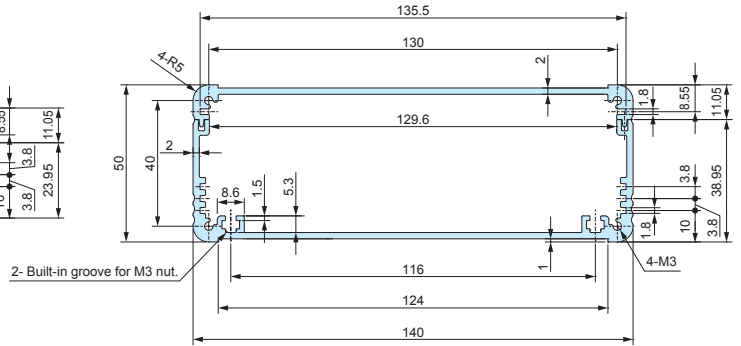

EXP • EXPE • EXW • EXPF • EXEF • EXWF15-8-□
EX14-7-□

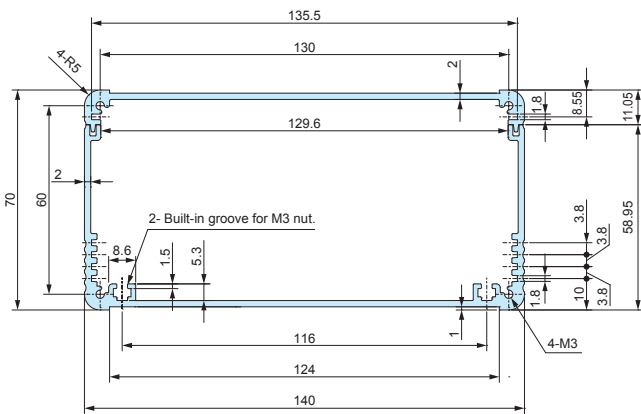

EXP • EXPE • EXW • EXPF • EXEF • EXWF15-10-□
EX14-9-□

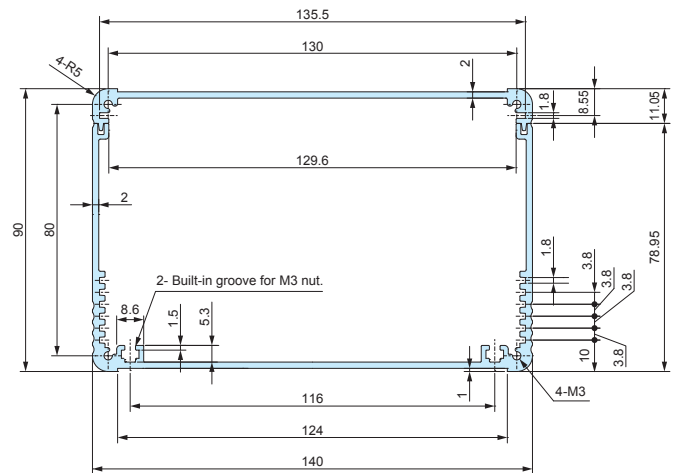

EXP • EXPE • EXPF • EXEF • EXWF • EX top / bottom covers

■ Drawings below are reference examples only.
DXF/DWG/PDF drawings available on our website.

EXP • EXPE • EXPF • EXEF • EXWF20-6-□
EX19-4-□

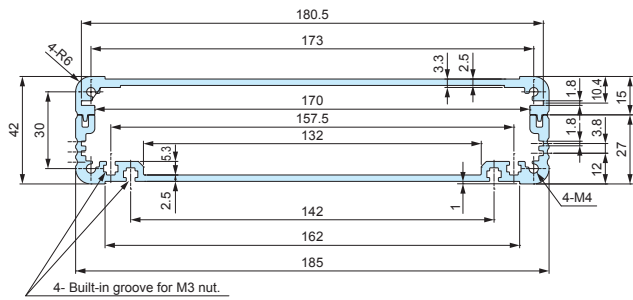

EXP • EXPE20-7-□
EXPF • EXEF • EXWF20-8-□
EX19-6-□

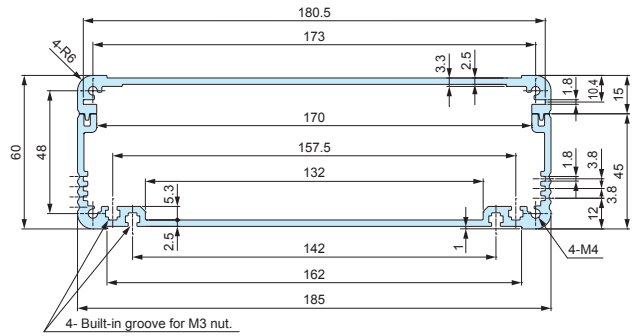

EXP • EXPE20-9-□
EXPF • EXEF • EXWF20-10-□
EX19-8-□

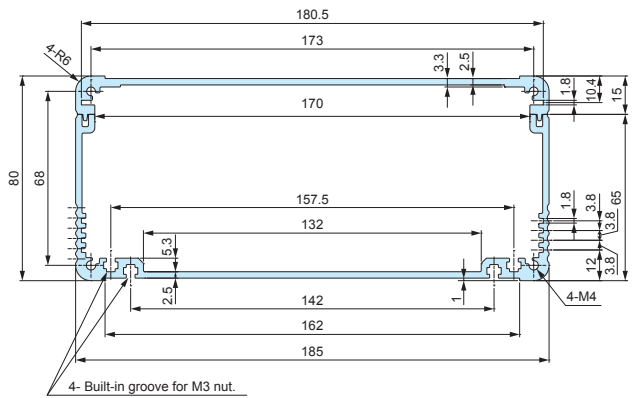

EXP • EXPE • EXPF • EXEF • EXWF20-12-□
EX19-11-□

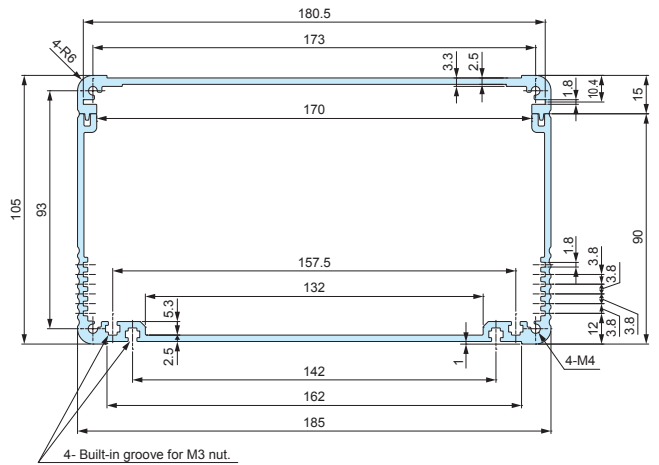

EXP • EXPE24-6-□
EXPF • EXEF • EXWF24-7-□
EX23-5-□

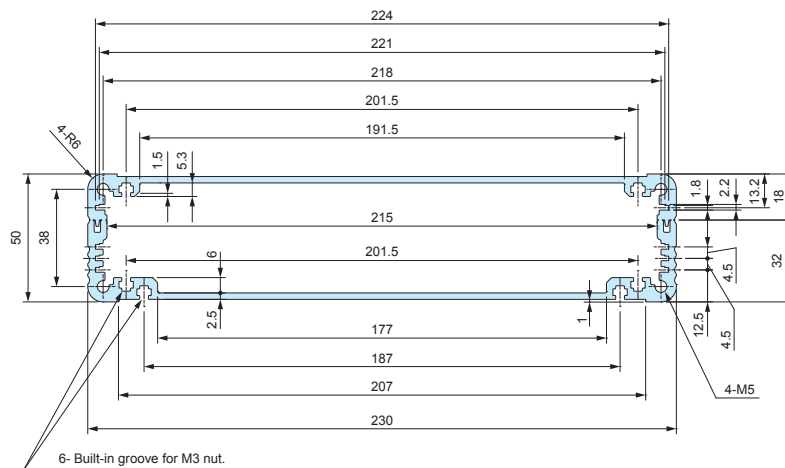

EXP • EXPE • EXPF • EXEF • EXWF • EX top / bottom covers

■ Drawings below are reference examples only.
DXF/DWG/PDF drawings available on our website.

EXP • EXPE • EXPF • EXEF • EXWF24-9-□
EX23-8-□

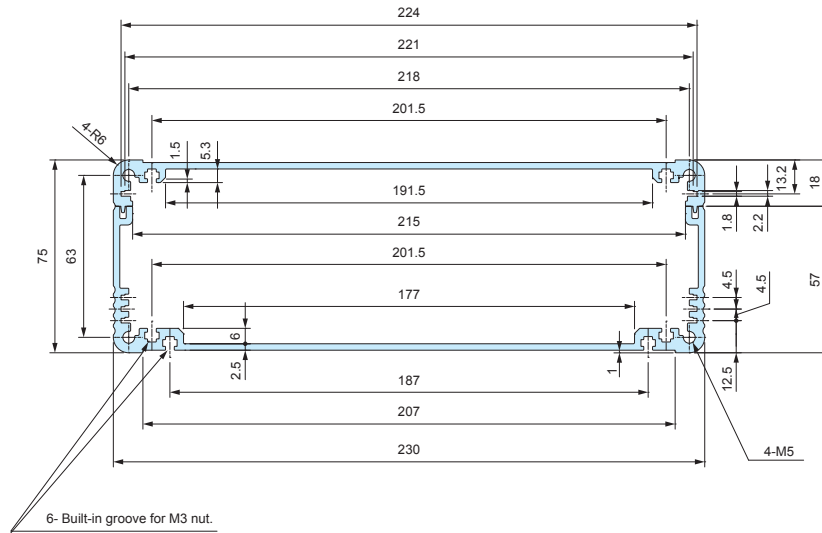

EXP • EXPE24-11-□
EXPF • EXEF • EXWF24-12-□
EX23-10-□

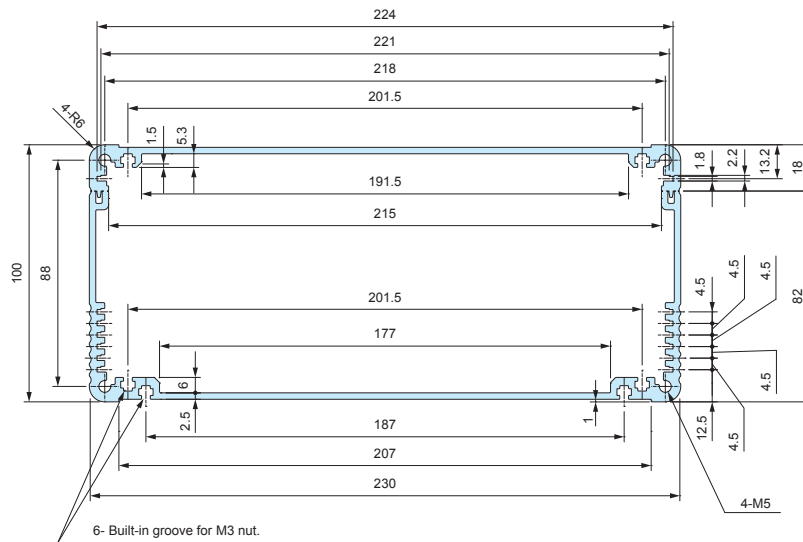

MT-3N

SLIDING NUT for EXP • EXPE • EXW • EXPF • EXEF • EXWF • EX

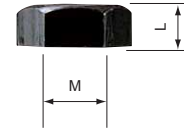
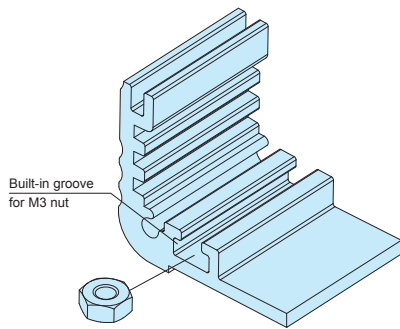

Product no. / Dimensions

Product no.	M	L	Material	Finish	Pack of
MT-3N	3	2.4	Steel	Black trivalent chromate	50

- Sliding nut can be used on all EXP • EXPE • EXW • EXPF • EXEF • EXWF • EX models with width 140mm or larger bottom covers, as well as with width 230mm top covers.

EXEG SERIES

EMC SHIELDING FABRIC-OVER-FOAM GASKET for EXPE • EXEF



- EMC shielding fabric-over-foam gasket for EXPE • EXEF series.

Suitable Enclosure

Product no.	Suitable enclosure
EXEG-2.5	EXPE7-□ • 9-□ • 12-□ • 15-□ / EXEF7-□ • 9-□ • 11-□ • 15-□
EXEG-3.2	EXPE20-□ • 24-□ / EXEF20-□ • 24-□



EMC Shielding Effects

Product no. / Dimensions

Product no.	Φ	Material	Color	Sales unit
EXEG-2.5	2.5	Wire mesh gasket • TPE	Metallic gray	500mm x 1 pc
NEW EXEG-3.2	3.2	Wire mesh gasket • TPE	Metallic gray	500mm x 1 pc

Length tolerance = +/- 10%

APPLICATION EXAMPLE EX series

PREMAIN POWER AMPLIFIER

Product by AY-densi (Japan)



USB EDGE NODE

Product by SHINWA (Japan)



BDN SERIES

IP67 DIECAST ALUMINIUM BOX

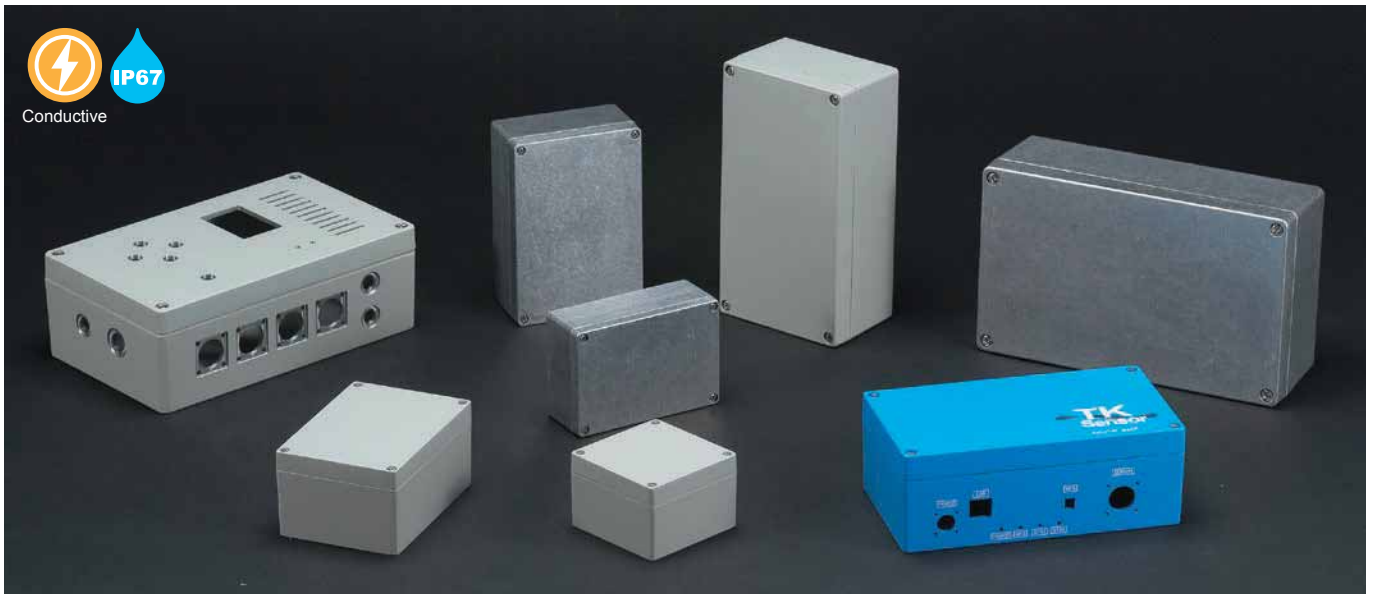

Technical Data

Protection class: IP67
 Operating temperature: -40°C ~ +105°C
 Recommended torque: 1.0N • m (10kgf • cm)

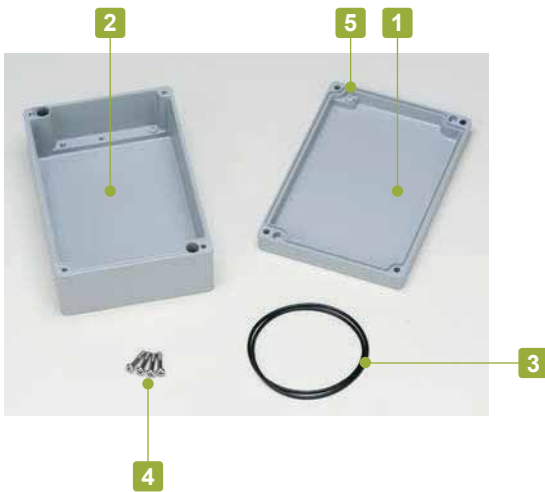

- 8 different sizes available for both light gray powder coated and unfinished models.
- O-ring gasket is good for maintaining both waterproof and dustproof functionality.
- Shock resistant diecast aluminium box.
- Conductivity can be achieved by utilization of the contact between the unfinished inner surfaces (only applicable to "N" type).

Components

No.	Part name	Pcs	Material	Color / Finish
1	Top cover	1	Diecast aluminium ADC12	Light gray • Silver / Powder coated • Unfinished
2	Base	1	Diecast aluminium ADC12	Light gray • Silver / Powder coated • Unfinished
3	O-ring gasket	1	Silicone	Black
4	Screw	4	Stainless steel	Unfinished
5	Earthing screw	2	Steel M4-5	Copper plated

Accessories (Optional parts)

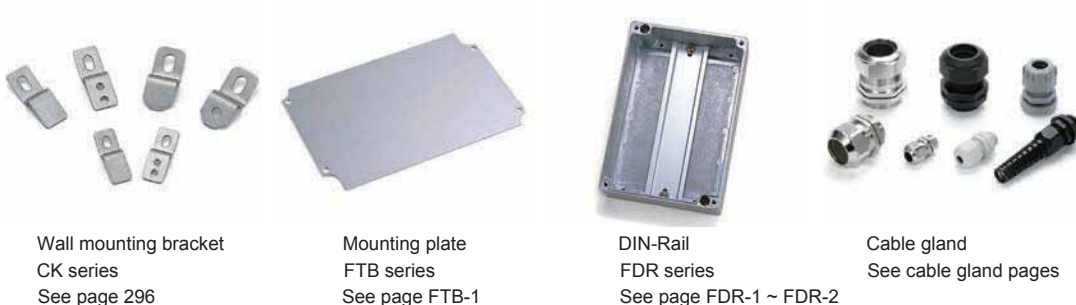

Wall mounting bracket
CK series
See page 296

Mounting plate
FTB series
See page FTB-1

DIN-Rail
FDR series
See page FDR-1 ~ FDR-2

Cable gland
See cable gland pages

BDN dimensions

■ DXF/DWG/PDF drawings available on our website.

BDN 6-8-5

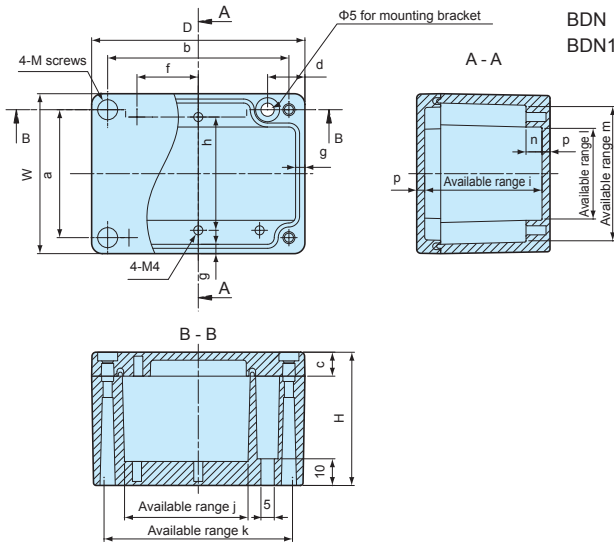

BDN 7-10-4
BDN 9-13-5
BDN11-16-6

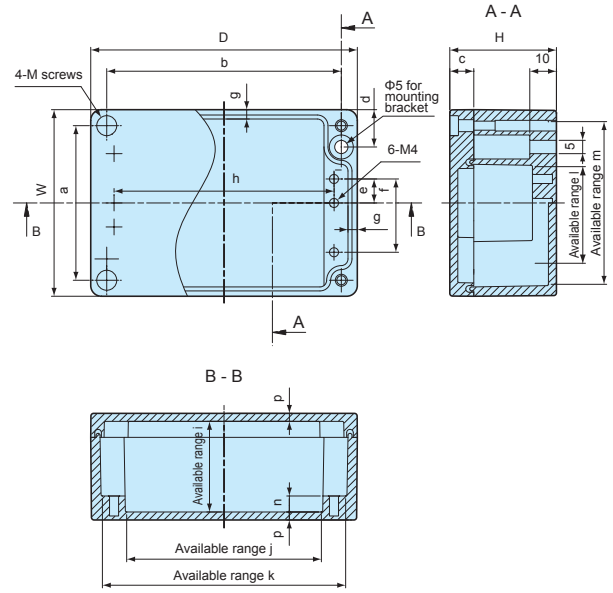

BDN 9- 9-6
BDN10-14-7
BDN12-22-8
BDN16-26-9

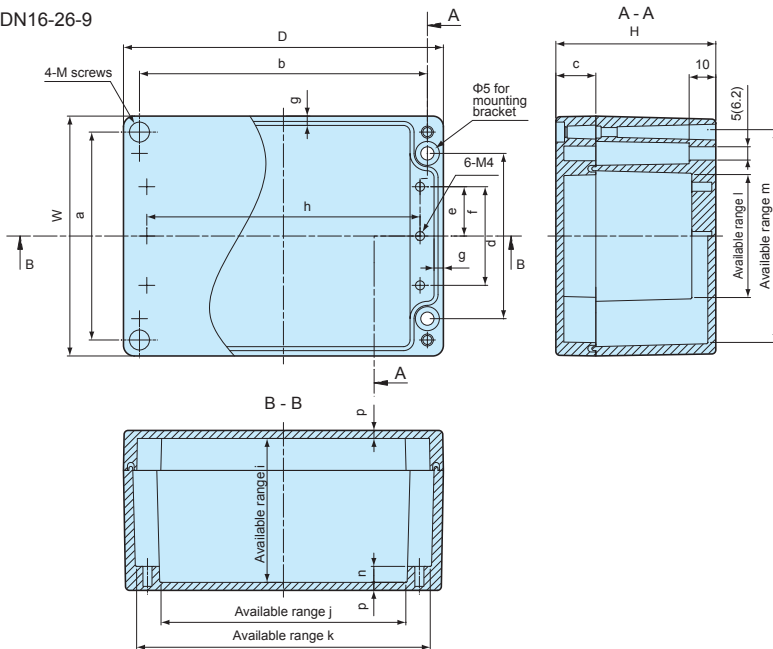

Dimension in () = BDN12-22-8
BDN16-26-9

Product no. / Dimensions

Product no.		Dimensions						Weight (g)
● Light gray	● Unfinished Conductive	W	D	H	a	b	c	
BDN 6- 8-5G	BDN 6- 8-5N	60	80	50	48	68	9	240
BDN 7-10-4G	BDN 7-10-4N	70	100	40	58	88	9	250
BDN 9- 9-6G	BDN 9- 9-6N	90	90	60	78	78	15	395
BDN 9-13-5G	BDN 9-13-5N	90	130	50	78	118	9	420
BDN10-14-7G	BDN10-14-7N	100	140	70	88	128	15	635
BDN11-16-6G	BDN11-16-6N	110	160	60	98	148	15	640
BDN12-22-8G	BDN12-22-8N	120	220	80	105	205	20	1,155
BDN16-26-9G	BDN16-26-9N	160	260	90	140	240	20	2,145

Product no.		Dimensions												
● Light gray	● Unfinished Conductive	d	e	f	g	h	i	j	k	ℓ	m	n	p	M
BDN 6- 8-5G	BDN 6- 8-5N	14	-	23	3.5	42.5	44	45	71	33	51	6	3	M4
BDN 7-10-4G	BDN 7-10-4N	14	11	31	3	85	34	75	92.5	38	62.5	6	3	M4
BDN 9- 9-6G	BDN 9- 9-6N	62	18.5	37	3.5	72	54	62	80	45	80	6	3	M4
BDN 9-13-5G	BDN 9-13-5N	14	19	47.5	3.5	112.5	44	104	121	56	81	6	3	M4
BDN10-14-7G	BDN10-14-7N	72	24	48	3.5	121	64	111	130	56	90	6	3	M4
BDN11-16-6G	BDN11-16-6N	14	29	67.5	3.5	142.5	54	134	151	76	101	6	3	M4
BDN12-22-8G	BDN12-22-8N	84.6	28	56	3.9	196	74	183	206	62	105	6	3	M5
BDN16-26-9G	BDN16-26-9N	110	36	72	4.8	230	82	216	247	87	146	9	4	M6

FTB SERIES

MOUNTING PLATE for BDN



FTB 5-7

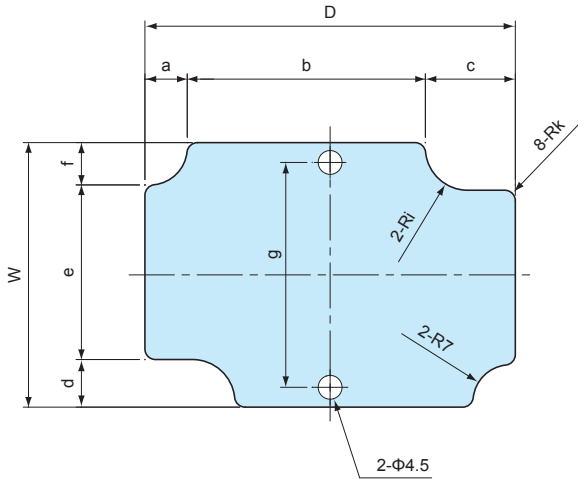

FTB 6-9

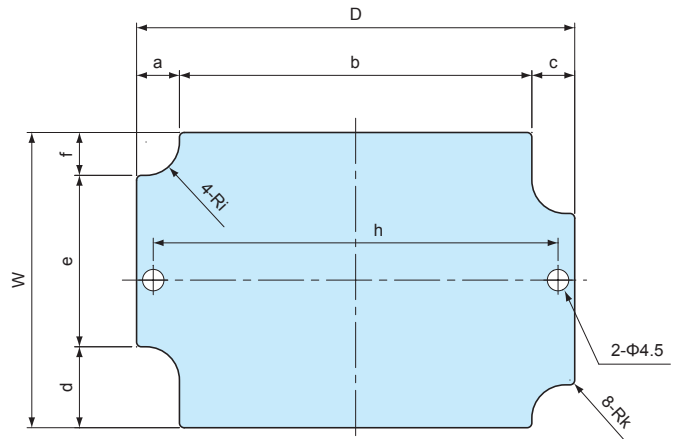

FTB 8-12
FTB10-15

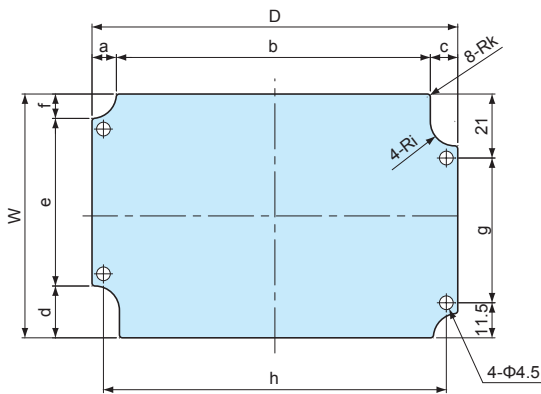

FTB 8- 8 FTB10-20
FTB 9-13 FTB14-24

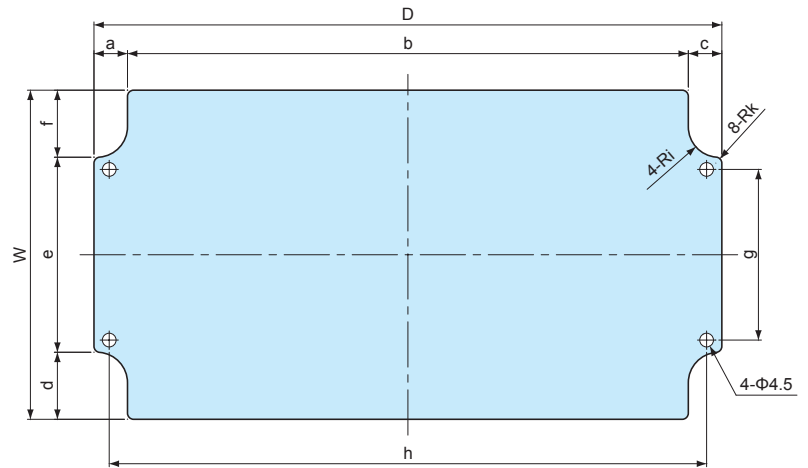

Material	Color / Finish
Aluminium A1050P t = 1.5	Silver / Anodized

Product no. / Dimensions

Product no.	Suitable box	W	D	a	b	c	d	e	f	g	h	i	k
FTB 5- 7	BDN 6- 8-5	50	70	8	45	17	9	33	8	42.5	-	8	2
FTB 6- 9	BDN 7-10-4	62	92	9	74	9	17	36	9	-	85	7	1
FTB 8- 8	BDN 9- 9-6	80	80	9	62	9	17	46	17	37	72.5	8	2
FTB 8-12	BDN 9-13-5	80	120	8	103	9	17	55	8	47.5	112.5	8	1
FTB 9-13	BDN10-14-7	89	129	9	111	9	17	55	17	48	121	8.5	2
FTB10-15	BDN11-16-6	100	150	8	133	9	17	75	8	67.5	142.5	8	1
FTB10-20	BDN12-22-8	108	206	11	184	11	22	64	22	56	196	10	2
FTB14-24	BDN16-26-9	144	244	15	214	15	30	84	30	72	230	12	3

FDR SERIES

DIN-RAIL



- DIN rail for installation of terminals, relays or switches inside enclosures.
- Available in different models and lengths to fit a wide variety of mounting boss pitch.
- FDR-1000 is available if customized length is required.

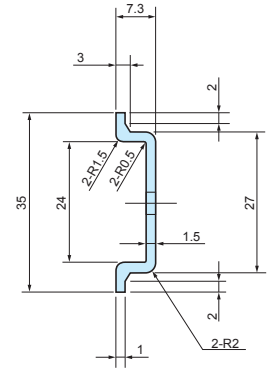
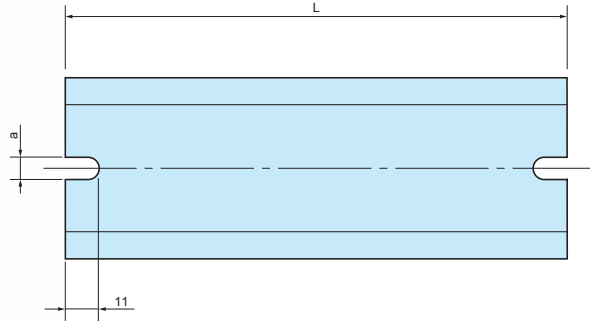

Feature

Material	Finish
Extruded Aluminium A6063S-T5	Silver anodized

Product no. / Dimensions

Product no.	L	a	Matching boss pitch
FDR- 50	50	4.2	32 ~ 42
57	57	4.2	39 ~ 49
66	66	4.2	48 ~ 58
77	77	4.2	59 ~ 69
80	80	4.2	62 ~ 72
87	87	4.2	69 ~ 79
92	92	4.2	74 ~ 84
100	100	4.2	82 ~ 92
106	106	4.2	88 ~ 98
110	110	4.2	92 ~ 102
120	120	4.2	102 ~ 112
128	128	4.2	110 ~ 120
137	137	4.2	119 ~ 129
142	142	4.2	124 ~ 134
146	146	4.2	128 ~ 138
150	150	4.2	132 ~ 142
168	168	4.2	150 ~ 160
170	170	4.2	152 ~ 162
186	186	4.2	168 ~ 178
202	202	4.2	184 ~ 194
205	205	4.2	187 ~ 197
223	223	4.2	205 ~ 215
226	226	4.2	208 ~ 218
235	235	4.2	217 ~ 227
242	242	4.2	224 ~ 234
249	249	4.2	231 ~ 241
283	283	4.2	265 ~ 275
300	300	4.2	282 ~ 292
350	350	4.2	332 ~ 342
450	450	4.2	432 ~ 442
550	550	4.2	532 ~ 542

Product no.	L	a	Matching boss pitch
FDR-B102	102	6.5	86 ~ 92
NEW B124	124	6.5	108 ~ 114
B142	142	6.5	126 ~ 132
B160	160	6.5	144 ~ 150
B165	165	6.5	149 ~ 155
B176	176	6.5	160 ~ 166
B183	183	6.5	167 ~ 173
B223	223	6.5	207 ~ 213
B260	260	6.5	244 ~ 250
B283	283	6.5	267 ~ 273
B303	303	6.5	287 ~ 293
B338	338	6.5	322 ~ 328
B360	360	6.5	344 ~ 350
B376	376	6.5	360 ~ 366
B383	383	6.5	367 ~ 373
B463	463	6.5	447 ~ 453
B560	560	6.5	544 ~ 550
B623	623	6.5	607 ~ 613
FDR-1000	1000	—	—

■ FDR-1000 does not have mounting holes.

Matching DIN-Rail Chart

BC□□ series

Product no.	Matching DIN-Rail
091207	FDR - 80
091208	80
101507	110
101508	110
112107	170
112110	170
112607	223
112610	223
BCAP	
BCPC	
BCPK	
BCAR	
BCPR	
131508	120
131808	150
131810	150
151509	120
151512	120
162110	170
162113	170
162610	223
162613	223
172211	170
172711	223

BDN series

Product no.	Matching DIN-Rail
6- 8- 5	FDR - 50
7-10- 4	-
9- 9- 6	FDR - 80
9-13- 5	120
10-14- 7	128
11-16- 6	150
12-22- 8	205
16-26- 9	242

BCAS series

Product no.	Matching DIN-Rail
071005	FDR - 92
080806	66
081104	92
081107	92
081108	92
081110	92
081307	110
081308	110
081807	168
081808	168
082507	235
082508	235
101007	77
101010	77
101807	150
102007	170
102307	202
121207	80
121210	80
141709	146
142309	205
151507	120
151510	120
152004	170
152007	170
152010	170
152013	170
152016	170
152510	226
152513	226
161607	137

SPCM • SPCP series

Product no.	Matching DIN-Rail
081304	FDR - 50/100
081305	50/100
081306	50/100
081308	50/100
081310	50/100
081313	50/100
101004	80
101006	80
131304	100
131305	100
131306	100
131308	100
131310	100
131313	100
SPCM	
SPCP	
131804	100/150
131805	100/150
131806	100/150
131808	100/150
131810	100/150
131813	100/150
131815	100/150
181808	150
181810	150
181813	150
181815	150
182508	150/223
182510	150/223
182515	150/223

Accessories (Optional parts)

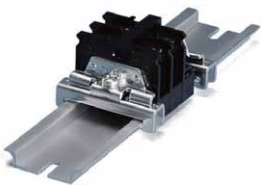

DIN-Rail stopper bracket TKR series
See page DIN-ACC-2



DIN-Rail mounting base DRA series
See page DIN-ACC-1



DIN-Rail mounting base DRT series
See page DIN-ACC-1

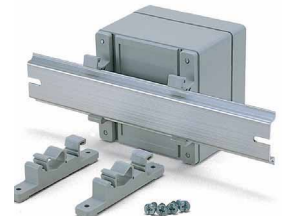

DIN-Rail mounting feet CKD series
See page DIN-ACC-2

DRA SERIES

DIN-RAIL MOUNTING BASE



NOTE

Before installation, please ensure that the lever is not fully hidden behind the enclosure.

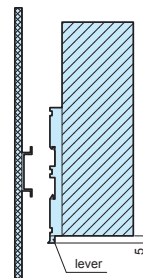

- For installation of enclosures, PCB and other parts onto a DIN rail.
- Simple installation and removal via the pull lever.

DRA-1

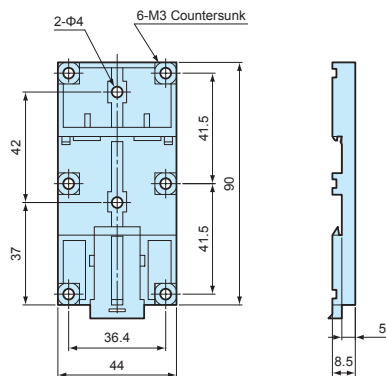

DRA-2

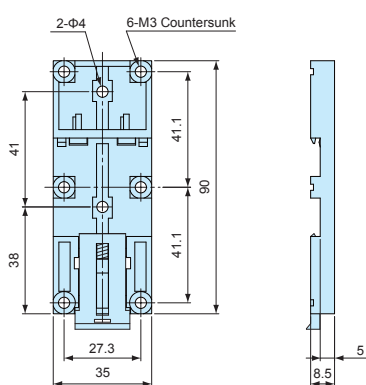

DRA-3

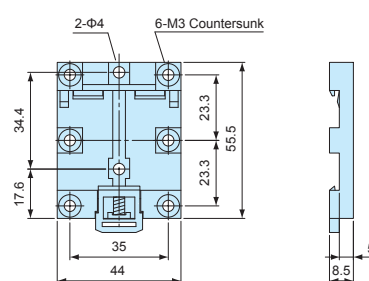

Product no. / Dimensions

Product no.	Material (body)	Material (lever)	Color	Weight (g)	Max load (kg)
DRA-1	PPE : SB UL94V-1	Nylon 66 UL94V-2	Black : Milky white	16.4	5
DRA-2	PPE : SB UL94V-1	Nylon 66 UL94V-2	Black : Milky white	14.5	5
DRA-3	PPE : SB UL94V-1	Nylon 66 UL94V-2	Black : Milky white	10.4	5

DRT SERIES

DIN-RAIL MOUNTING BASE

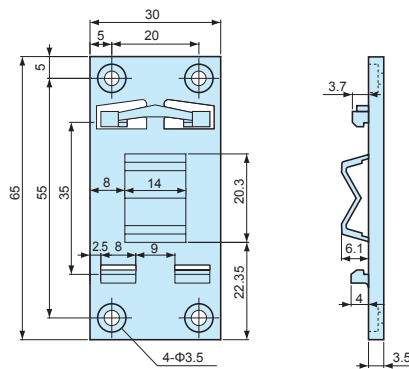

NOTE

Before installation, please ensure that the length (from top) of the enclosure is equal to, or less than 100mm from the center of the mounting base.

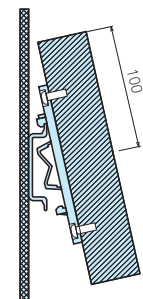

- For installation of enclosures, PCB and other parts onto a DIN rail.
- Simple installation and removal by tilting the case at an angle and sliding it in/out.

Product no. / Dimensions

Product no.	Material	Color	Weight (g)	Max load (kg)
DRT-1	PBT UL94V-0	Light gray	7.3	1

CKD SERIES

DIN-RAIL MOUNTING FEET

Installation example

■ DXF/DWG/PDF drawings available on our website.

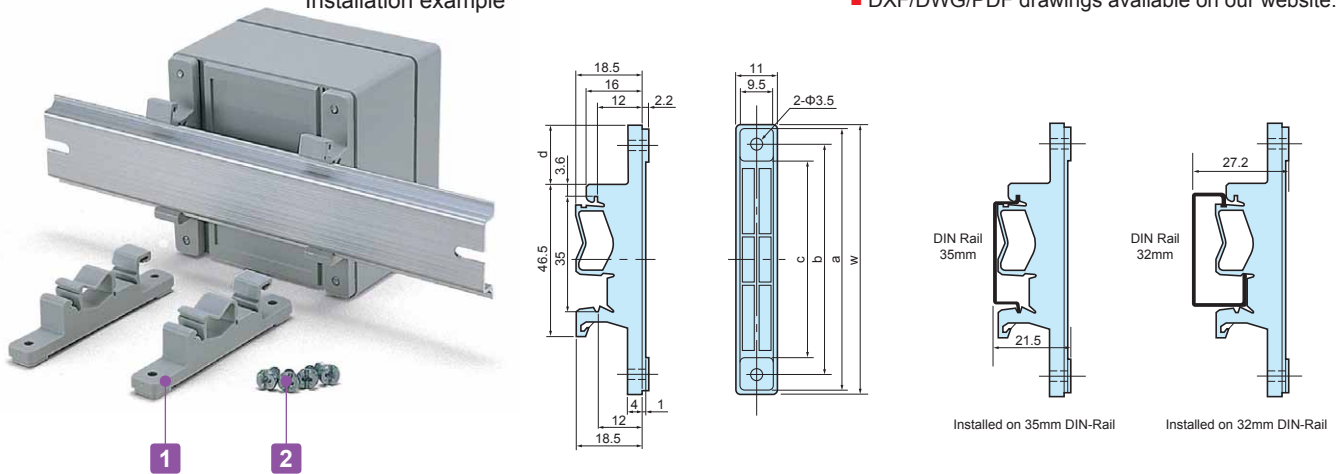

■ Mounting feet for installation of enclosures, PCB and other parts onto a DIN rail. Can be easily detached.

Technical Data
Max load : 3kg

Components

No.	Part name	Pcs	Material	Color / Finish
1	Mounting feet	2	Polyamide	White gray
2	Screw (special type 4.2 x 9.5)	4	Screw	Unichrome plated

Product no. / Dimensions

Product no.	W	a	b	c	d	Pack of
CKD- 80	77	75	66	56	17	2
CKD-120	117	115	106	96	37	2
CKD-160	157	155	147	136	57	2

TKR SERIES

DIN-RAIL TERMINAL BLOCKS END STOPPER

■ DXF/DWG/PDF drawings available on our website.

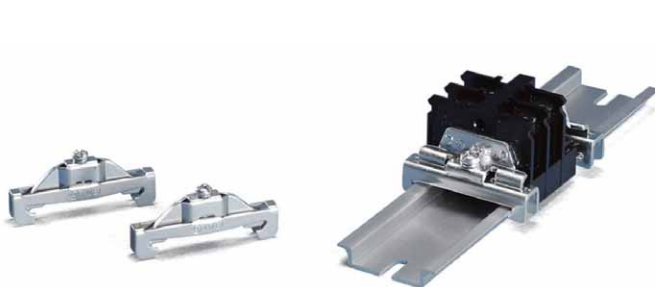

TKR-TWE1

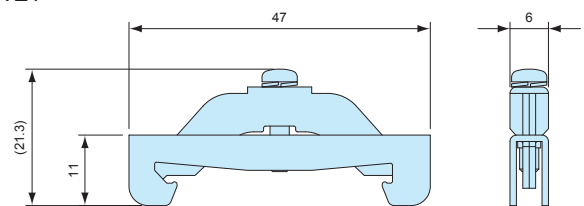

TKR-JTXE3

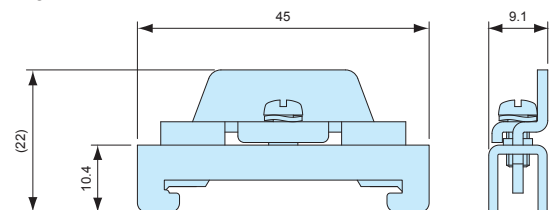

- Stopper bracket for use with 35mm DIN-rail to keep an attachment at a fixed location.
- TKR-TWE1 is used with small DIN rail attachment parts. For larger/higher attachment parts, TKR-JTXE3 is recommended for providing additional support.

Product no. / Feature

Product no.	Material	Color / Finish	Pack of
TKR-TWE1	Steel sheet	Trivalent chromate	2
TKR-JTXE3	Steel sheet	Trivalent chromate	2

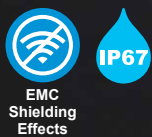

Technical Data
Protection class : IP67
Operating temperature : -40°C ~ +105°C
Recommended torque : 1N • m

Silicone gasket (waterproof)
Stainless steel mesh gasket (EMC Shielding)

- A double gasket construction allows both IP67 protection and EMC shielding to be possible.
- 13 different sizes available with 2 different finish types.
- Suitable for CATV terminal, fiber optic transmitter, FA controller, and so on.
- Available in powder coated model and unfinished model.

APPLICATION EXAMPLE

CATV OPTICAL NODE



LPWA OUTDOOR GATEWAY



WIFI ACCESS POINT

Accessories (Optional parts)



Mounting bracket HQF series
See page HQ-7



Pole Mounting bracket SSK series
See page SSK-M-1 ~ SSK-M-3

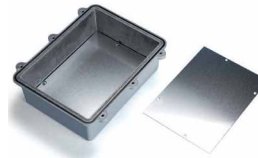

Mounting plate HQP series
See page HQ-8



Mounting screw MT series
See page HQ-7



Cable gland
See cable gland pages



Protective vent PMF series
See PMF pages

Product no. / Dimensions

Product no.		Dimensions			Weight (g)
● Light gray	○ Unfinished	W	D	H	
HQ10-10- 5G	HQ10-10- 5N	96.3	96.8	45	302
HQ10-10- 7G	HQ10-10- 7N	96.8	96.8	67	335
HQ15-10- 5G	HQ15-10- 5N	150	100	50	442
HQ15-10- 8G	HQ15-10- 8N	150	99.5	75	494
HQ16-16- 6G	HQ16-16- 6N	162	162	55	626
HQ16-16- 8G	HQ16-16- 8N	162	162	80	715
HQ19-10- 5G	HQ19-10- 5N	192	96	45	507
HQ19-10- 7G	HQ19-10- 7N	192	96	67	590
HQ20-15- 5G	HQ20-15- 5N	200	150	50	753
HQ20-15- 8G	HQ20-15- 8N	200	150	75	849
HQ26-18- 6G	HQ26-18- 6N	262	181.5	55	961
HQ27-17- 7G	HQ27-17- 7N	274.2	173.2	66	1,129
HQ27-17-10G	HQ27-17-10N	274.2	172.7	100	1,287

HQ dimensions

HQ10-10-5
HQ10-10-7

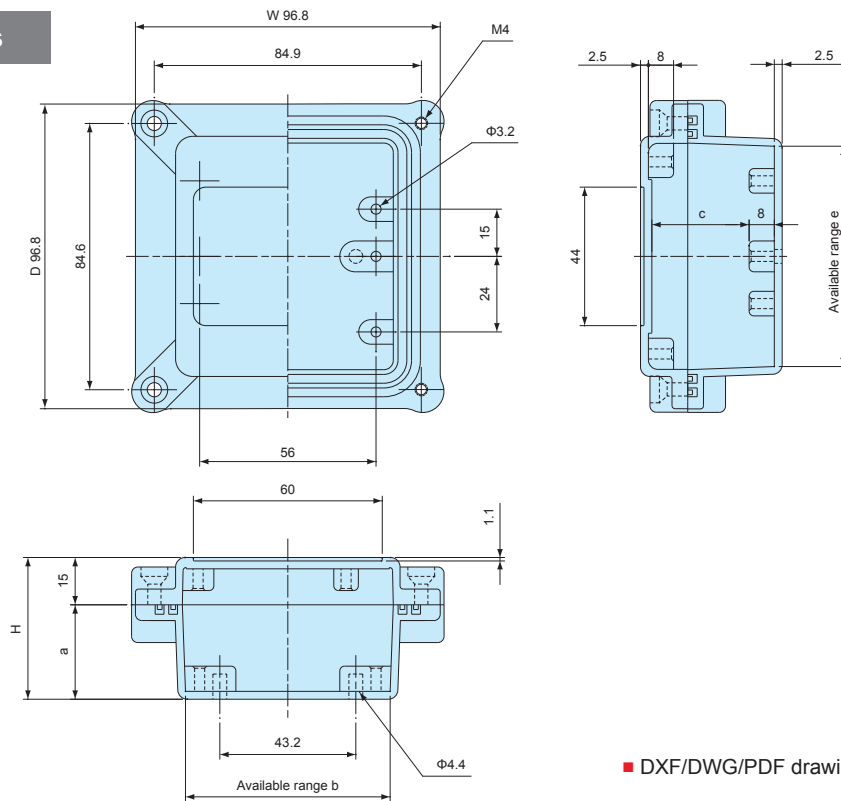

■ DXF/DWG/PDF drawings available on our website.

Product no.	W	D	H	a	b	c	e
HQ10-10- 5	96.3	96.8	45	30	64	30.9	69
HQ10-10- 7	96.8	96.8	67	52	64	52.9	69

HQ dimensions

■ DXF/DWG/PDF drawings available on our website.

HQ15-10-5
HQ15-10-8

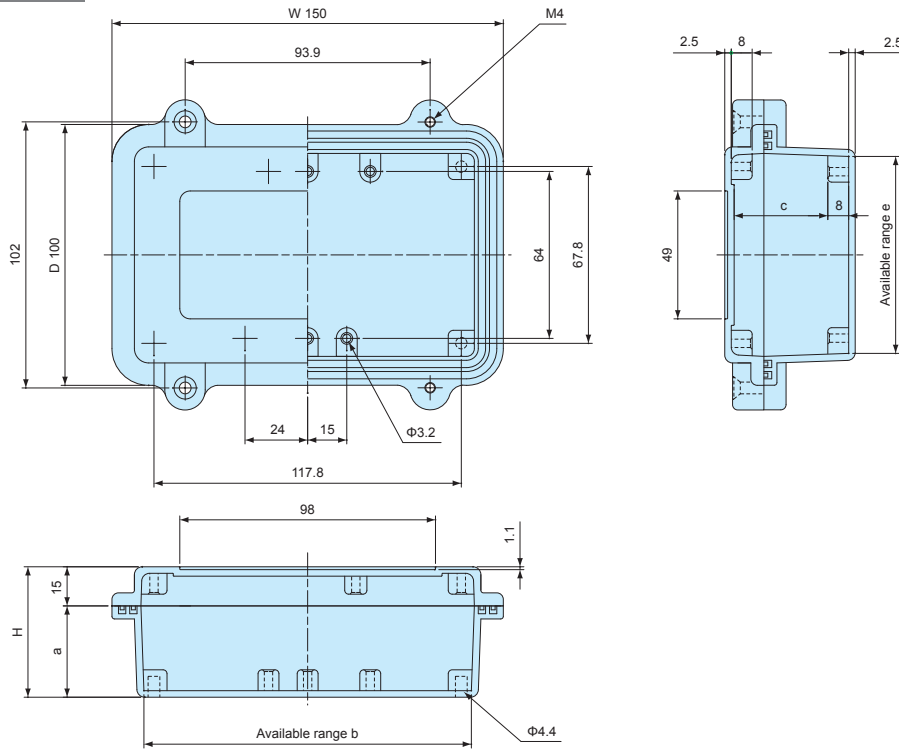

Product no.	W	D	H	a	b	c	e
HQ15-10- 5	150	100	50	35	125.5	35.9	75.5
HQ15-10- 8	150	99.5	75	60	123.7	60.9	73.7

HQ16-16-6
HQ16-16-8

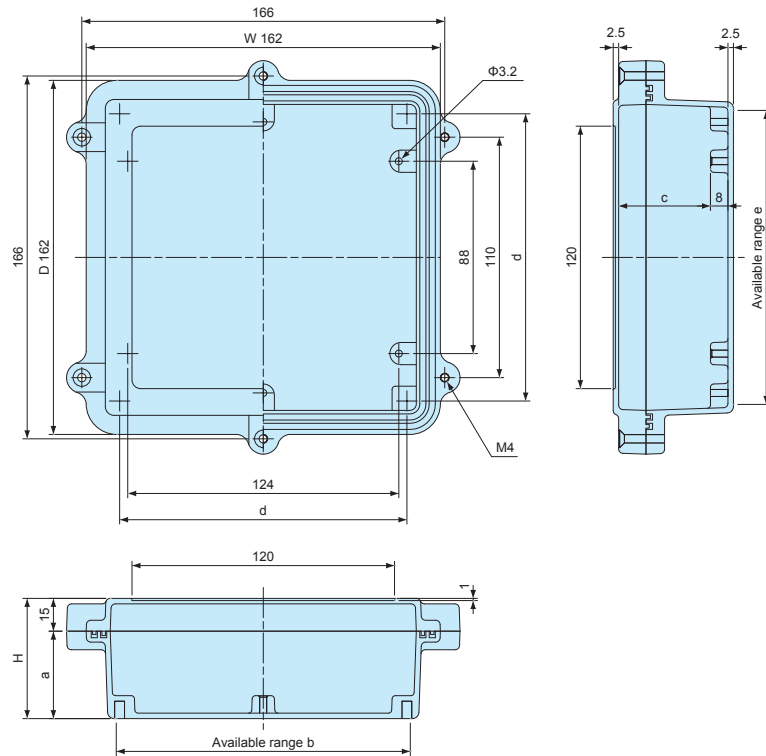

Product no.	W	D	H	a	b	c	d	e
HQ16-16- 6	162	162	55	40	134.5	42	131.41	134.5
HQ16-16- 8	162	162	80	65	132.7	67	129.66	132.7

HQ dimensions

■ DXF/DWG/PDF drawings available on our website.

HQ19-10-5
HQ19-10-7

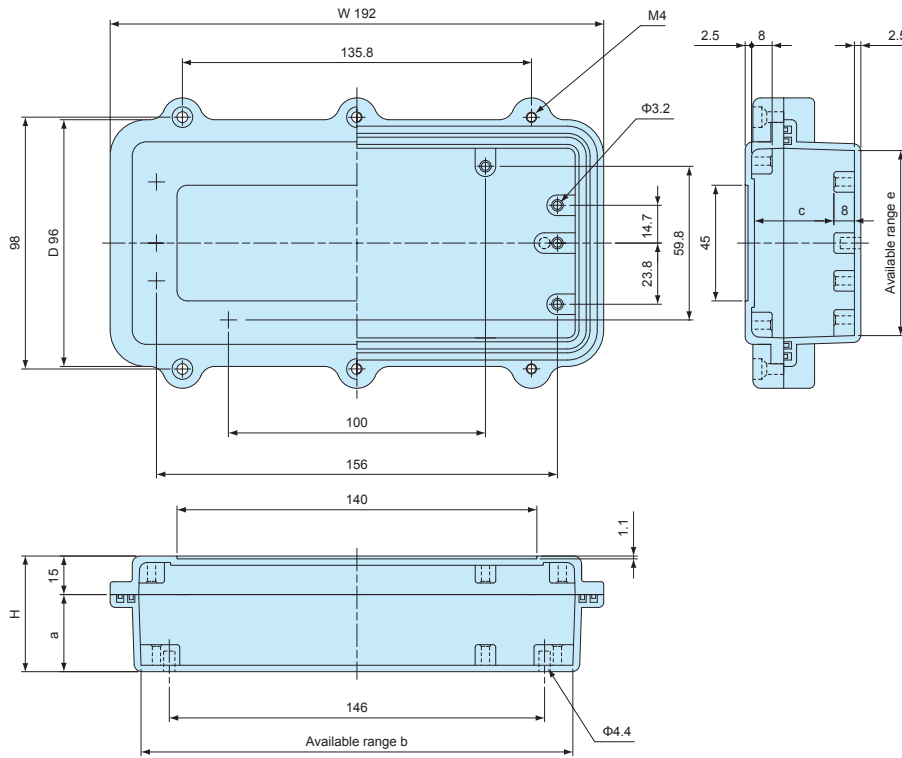

Product no.	W	D	H	a	b	c	e
HQ19-10- 5	192	96	45	30	168	30.9	72
HQ19-10- 7	192	96	67	52	166.6	52.9	70.6

HQ20-15-5
HQ20-15-8

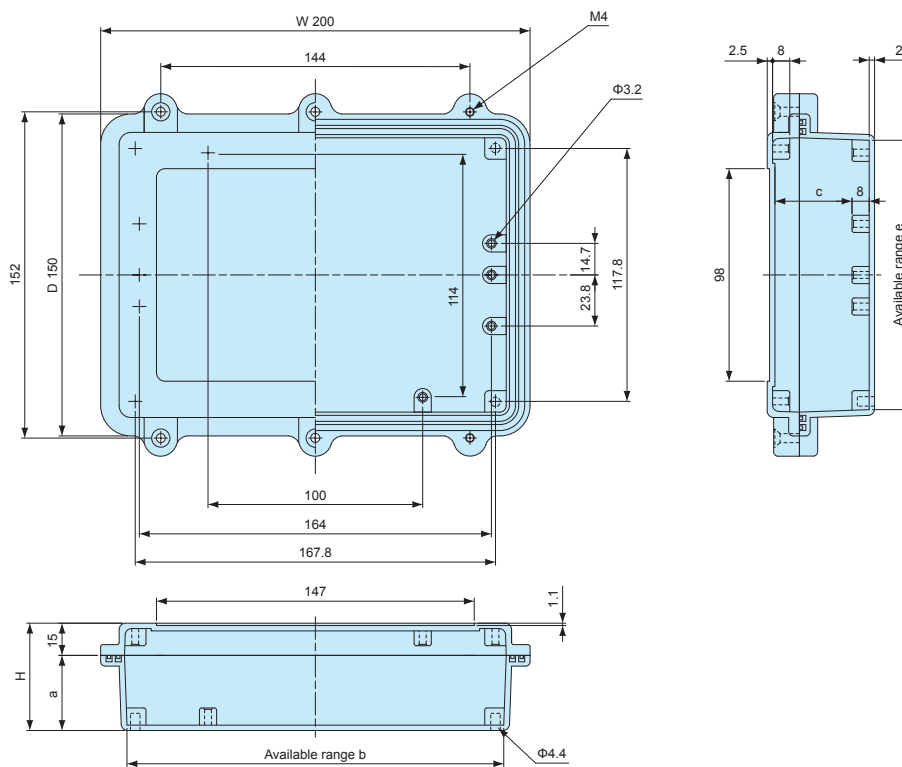

Product no.	W	D	H	a	b	c	e
HQ20-15- 5	200	150	50	35	175.5	35.9	125.5
HQ20-15- 8	200	150	75	60	173.7	60.9	123.7

HQ dimensions

■ DXF/DWG/PDF drawings available on our website.

HQ26-18-6

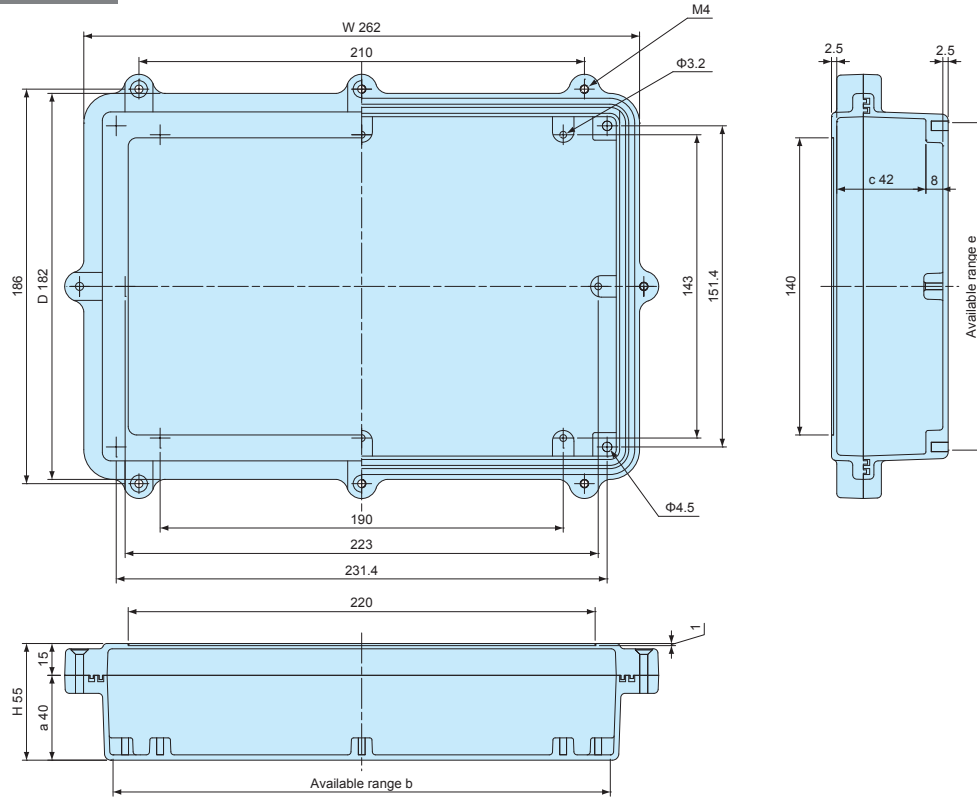

Product no.	W	D	H	a	b	c	e
HQ26-18- 6	262	181.5	55	40	234.4	42	154.4

HQ27-17- 7
HQ27-17-10

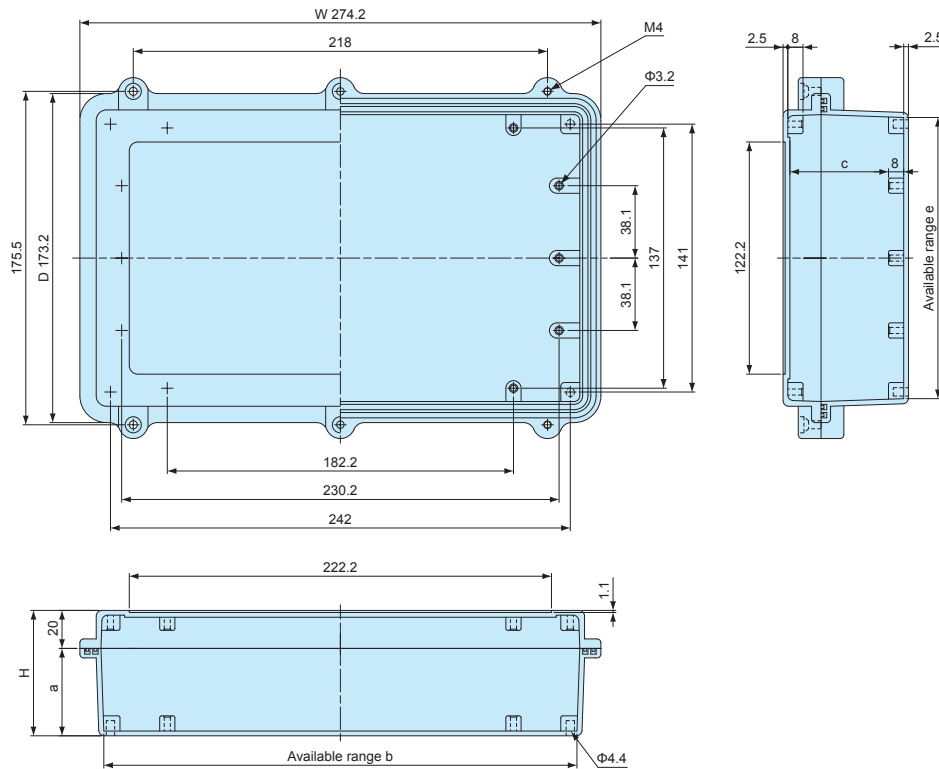

Product no.	W	D	H	a	b	c	e
HQ27-17- 7	274.2	173.2	66	46	249	51.9	148
HQ27-17-10	274.2	172.7	100	80	249	85.9	148

EMI SHIELDING TEST DATA

Test Result
by Gestek

97.0 dBuV/m

Date : 2007/12/20

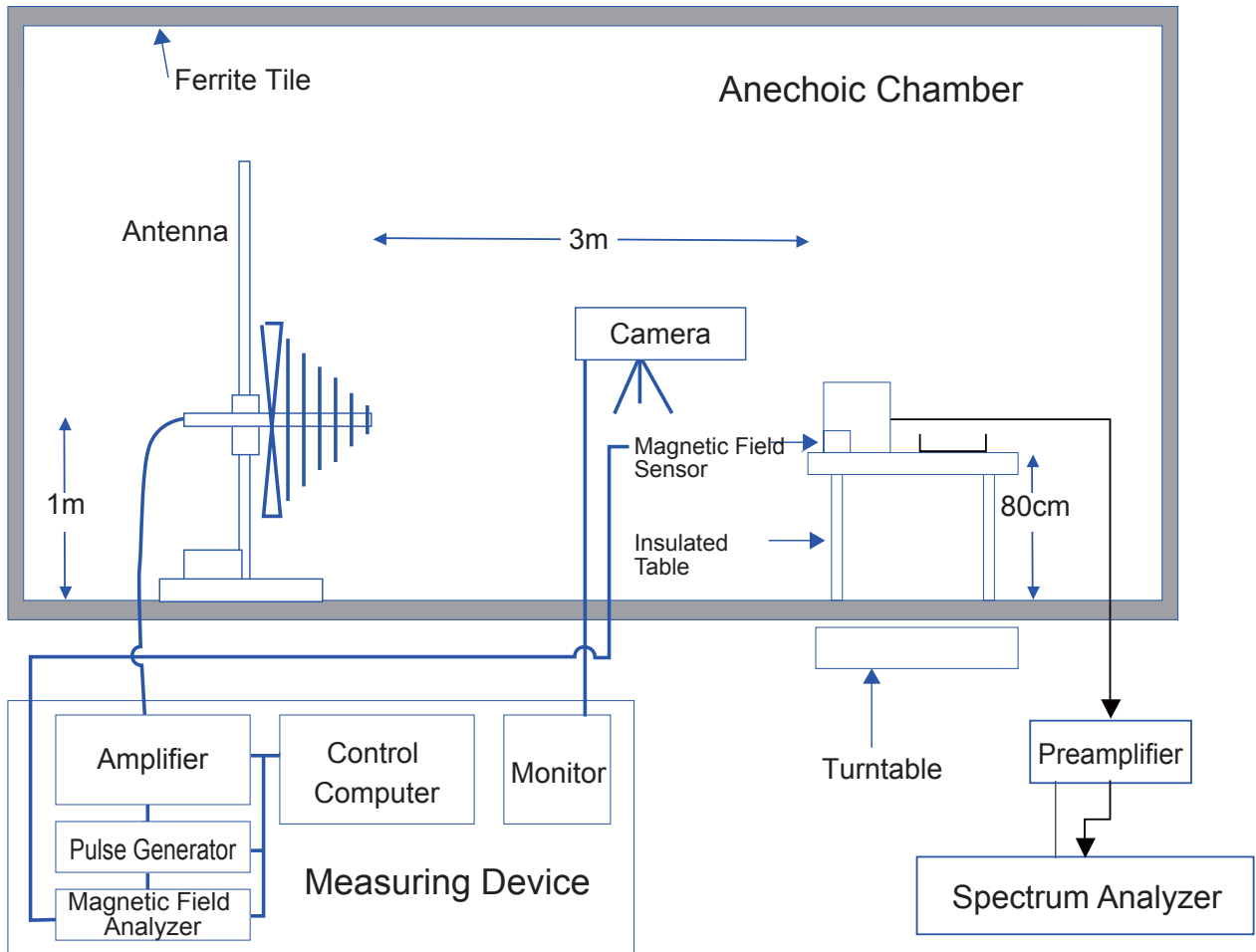
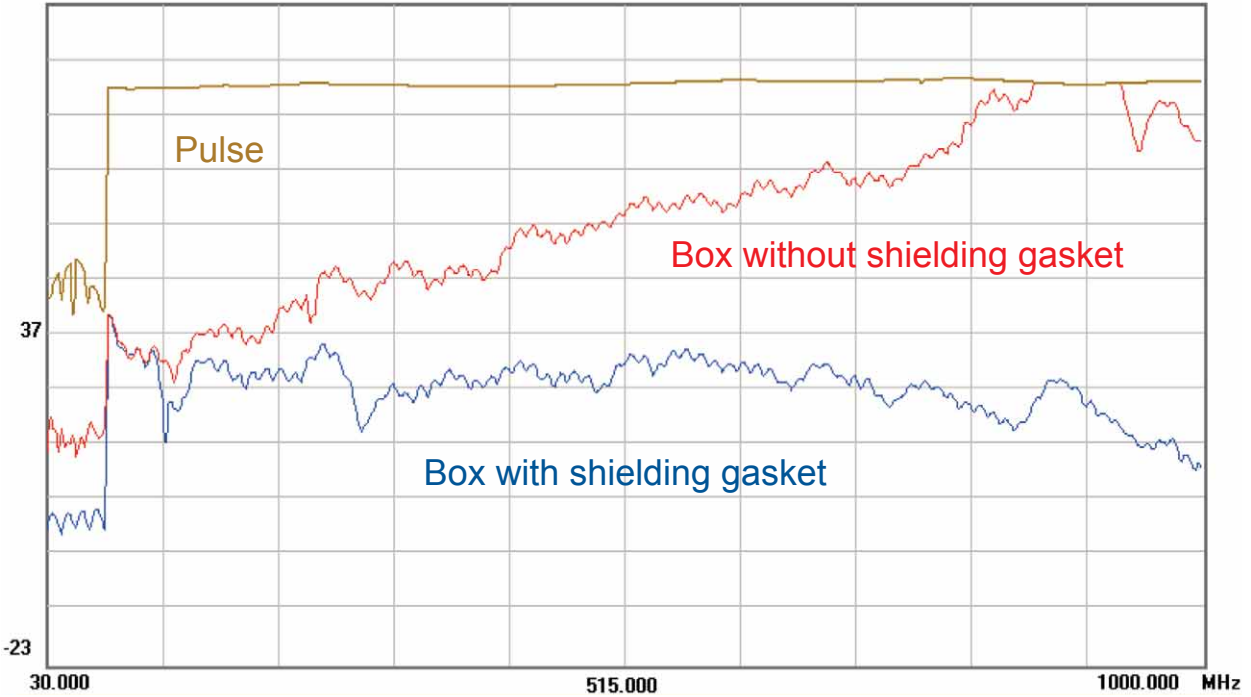

HQF SERIES

MOUNTING BRACKET for HQ

■ DXF/DWG/PDF drawings available on our website.

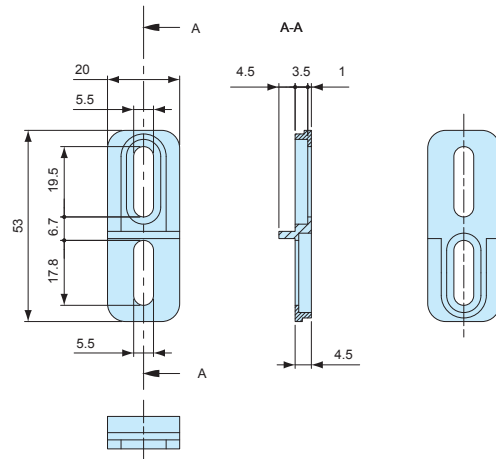

Components

Part name	Pcs	Material	Color / Finish
Mounting bracket	4	Diecast aluminium ADC12	Powder coated • Unfinished
Screw	4	Stainless steel	Unfinished

Product no. / Feature

Product no.	Color / Finish	Suitable box	Pack of
HQF-1G	Light gray / Powder coated	HQ all models	4
HQF-1N	Unfinished	HQ all models	4

MT SERIES

MOUNTING SCREW for HQ



Product no. / Feature

Product no.	Material	Color / Finish	Pack of
MT3.5-8K	Steel	Trivalent chromate	4

HQG SERIES

WATERPROOF GASKET for HQ



Product no. / Suitable box

Product no.	Suitable box
HQG1010	HQ10-10-□
HQG1510	HQ15-10-□
HQG1616	HQ16-16-□
HQG1910	HQ19-10-□
HQG2015	HQ20-15-□
HQG2618	HQ26-18-□
HQG2717	HQ27-17-□

■ Material : Silicone

HQE SERIES

SHIELDING GASKET for HQ



Product no. / Suitable box

Product no.	Suitable box
HQE1010	HQ10-10-□
HQE1510	HQ15-10-□
HQE1616	HQ16-16-□
HQE1910	HQ19-10-□
HQE2015	HQ20-15-□
HQE2618	HQ26-18-□
HQE2717	HQ27-17-□

■ Material : Stainless steel • Silicone (White)

HQP SERIES

MOUNTING PLATE for HQ

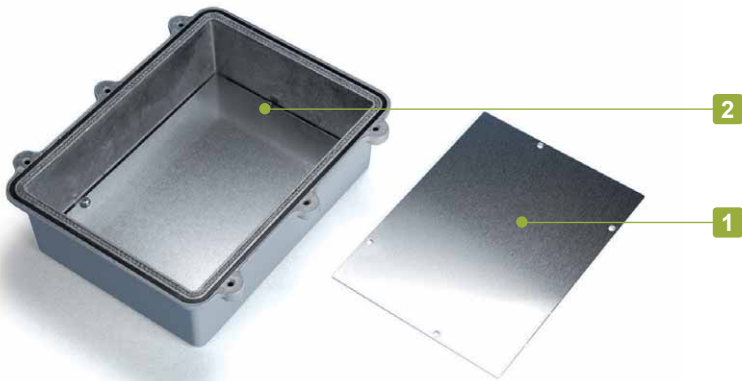

Components

No.	Part name	Pcs	Material	Color / Finish
1	Mounting plate	1	Aluminium A1050P t = 1.5	Unfinished
2	Screw (MT3.5-8K)	4	Steel	Trivalent chromate

■ Drawings below are reference examples only.
DXF/DWG/PDF drawings available on our website.

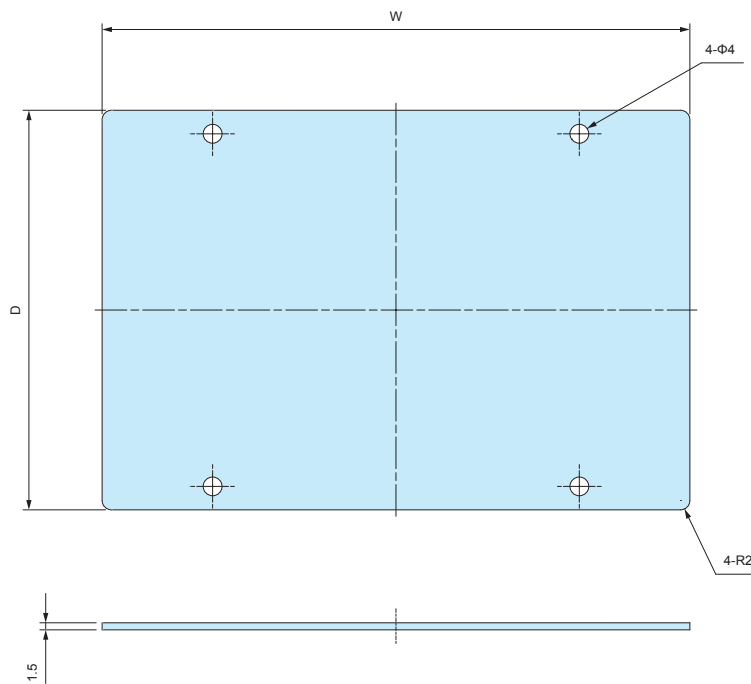

Product no. / Dimensions

Product no.	W	D	Suitable box
HQP10-10	63	68	HQ10-10-5 • HQ10-10-7
HQP15-10	122	72	HQ15-10-5 • HQ15-10-8
HQP16-16	132	132	HQ16-16-6 • HQ16-16-8
HQP19-10	166	70	HQ19-10-5 • HQ19-10-7
HQP20-15	172	122	HQ20-15-5 • HQ20-15-8
HQP26-18	235	155	HQ26-18-6
HQP27-17	248	147	HQ27-17-7 • HQ27-17-10

SSK SERIES

POLE MOUNTING BRACKET

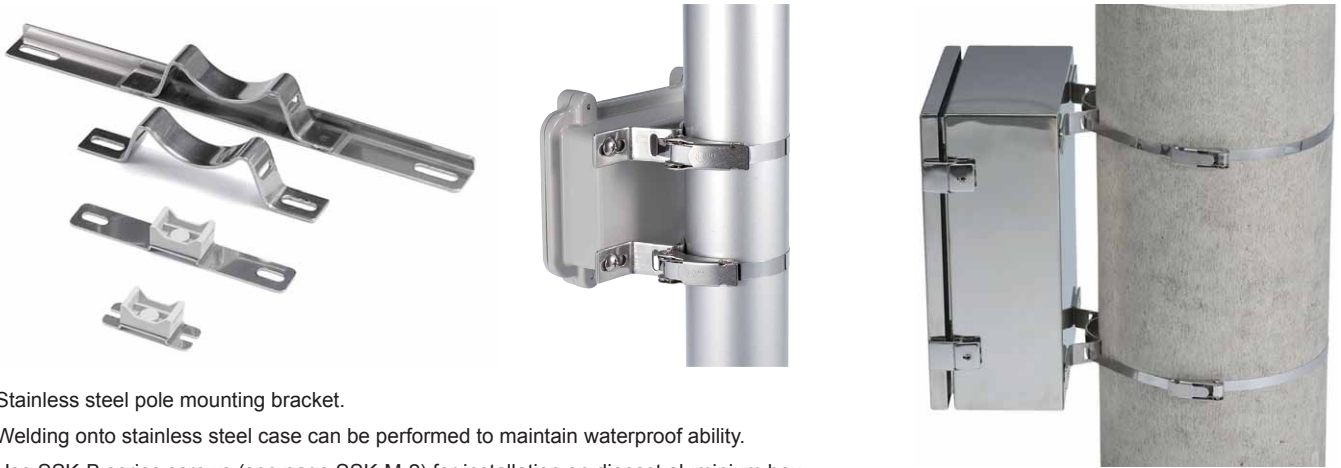

- Stainless steel pole mounting bracket.
- Welding onto stainless steel case can be performed to maintain waterproof ability.
- Use SSK-B series screws (see page SSK-M-2) for installation on diecast aluminium box.
- Use PKB mounting belt (see page PKB-1) for installation onto a pole.

SSK dimensions

■ DXF/DWG/PDF drawings available on our website.

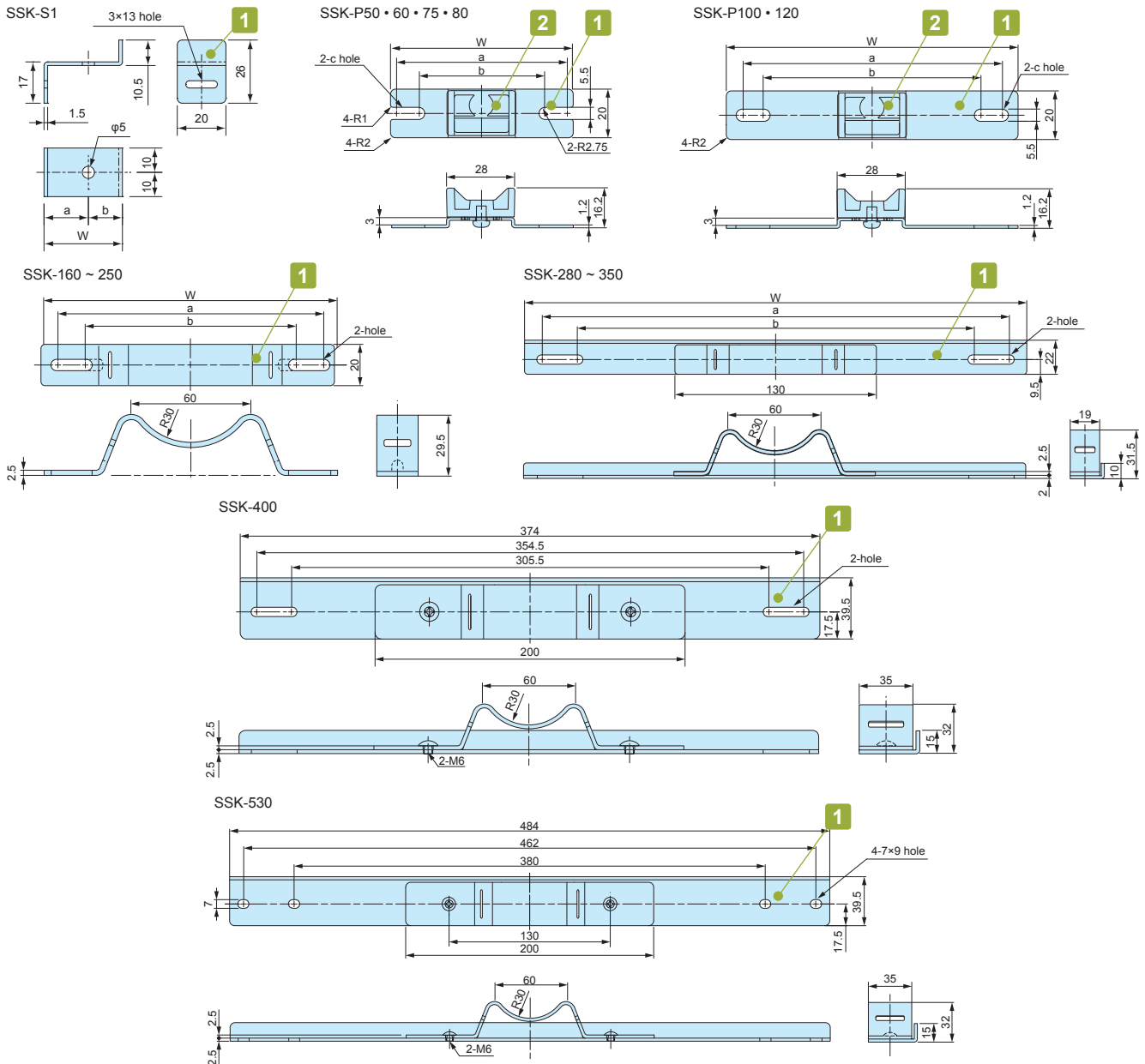

Components

No.	Part name	Pcs	Material	Color / Finish
1	Bracket	2	Stainless steel SUS304	Barrel finish
2	Mounting bracket (SSK-P models only)	2	ASA UL94HB	White gray

Product no. / Dimensions

Product no.	W	a	b	c	Suitable mounting belt	Pack of
SSK-S1	32.25	18.25	14	—	PKB-10PM, 10P, PKB-10S	4
SSK-P50	50	44.5	37.5	5.5× 9	PKB-10PM, 10P, PKB-10S	2
SSK-P60	60	54.5	47.5	5.5× 9	PKB-10PM, 10P, PKB-10S	2
SSK-P75	75	69.5	55.5	5.5×12.5	PKB-10PM, 10P, PKB-10S	2
SSK-P80	80	74.5	64.5	5.5×10.5	PKB-10PM, 10P, PKB-10S	2
SSK-P100	100	88.1	76.5	5.5×11.3	PKB-10PM, 10P, PKB-10S	2
SSK-P120	120	106.5	88.5	5.5×14.5	PKB-10PM, 10P, PKB-10S	2
SSK-160	142	129.5	106.5	—	PKB-10PM, 10P, PKB-10S	2
SSK-170	152	142.3	101	—	PKB-10PM, 10P, PKB-10S	2
SSK-200	174	161.5	112.5	—	PKB-10PM, 10P, PKB-10S	2
SSK-210	192	180.5	131.5	—	PKB-10PM, 10P, PKB-10S	2
SSK-250	230	215.5	166.5	—	PKB-10PM, 10P, PKB-10S	2
SSK-280	260	244.5	195.5	—	PKB-10PM, 10P, PKB-10S	2
SSK-300	280	264.5	215.5	—	PKB-10PM, 10P, PKB-10S	2
SSK-350	324	302.5	253.5	—	PKB-10PM, 10P, PKB-10S	2
SSK-400	374	354.5	305.5	—	PKB-20S	2
SSK-530	484	462	380	7×9	PKB-20S	2

SSK-B SERIES

MOUNTING SCREW SET for SSK

- Mounting screw set for use with SSK pole mounting bracket.
- See below chart for appropriate screw / box combination.
- Material / Finish : Stainless steel / Unfinished.

Product no. / Dimensions

Product no.	Included screws	Suitable box	Pcs
SSK-B4-15N	M4-15 Pan head with nut	AW5-4-7 ~ AW8-5-18	4
SSK-B4-25N	M4-25 Pan head with nut	BDN9-9-6, BDN10-14-7	4
SSK-B5-8T	M5-8 Binding head tapping	HQ series	4
SSK-B5-15N	M5-15 Pan head with nut	AW9-9-10 ~ AW21-9-31	4
SSK-B5-25N	M5-25 Pan head with nut	BDN12-22-8, BDN16-26-9	4

- Installation Example

M5 thread fastening

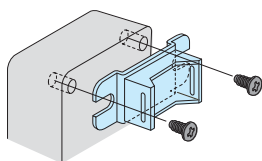

SSK-B5-8T

M4/M5 Pan head with nut fastening

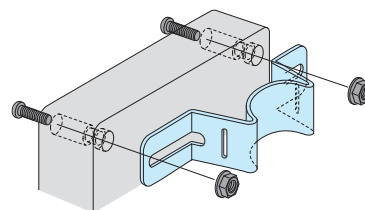

SSK-B4-15N SSK-B4-25N
 SSK-B5-15N SSK-B5-25N
 SSK-B5-35N SSK-B6-40N

POLE MOUNTING BRACKET / SCREW SET MATCHING CHART

BDN series

Box Product no.		SSK Product no.		Screw set Product no.
		Vertical mount	Horizontal mount	
BDN	9-9-6	SSK-P75	SSK-P100	SSK-B4-25-N
	10-14-7	SSK-P80	SSK-160	SSK-B4-25-N
	12-22-8	SSK-P100	SSK-250	SSK-B5-25-N
	16-26-9	SSK-160	SSK-280	SSK-B5-25-N

HQ series

Box Product no.		SSK Product no.		Screw set Product no.
		Vertical mount	Horizontal mount	
HQ	10-10-5 • 10-10-7	SSK-P50	—	SSK-B5-8T
	15-10-5 • 15-10-8	SSK-P80	SSK-160	SSK-B5-8T
	15-11-3	SSK-P100	SSK-160	SSK-B5-8T
	16-16-6 • 16-16-8	SSK-170	SSK-170	SSK-B5-8T
	19-10-5 • 19-10-7	—	SSK-200	SSK-B5-8T
	20-15-3 • 20-15-5 • 20-15-9	SSK-160	SSK-210	SSK-B5-8T
	26-18-6	SSK-200	SSK-280	SSK-B5-8T
	27-17-7 • 27-17-10	SSK-170	SSK-280	SSK-B5-8T

SSM • SSB series ■ Installation should be done by welding.

Box Product no.			SSK Product no.		
			Vertical mount	Horizontal mount	
SSM SSB	121508		SSK-S1	—	
	151508	152206	152210	SSK-160	—
	202010	202806		SSK-210	—
	202812	223312			
	304015			SSK-300	—

■ SSK bracket is different depending on mount type (Vertical or Horizontal).

Vertical mount
(Longer vertical side)

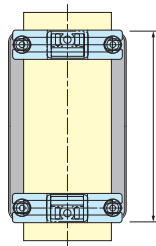

Horizontal mount
(Longer horizontal side)

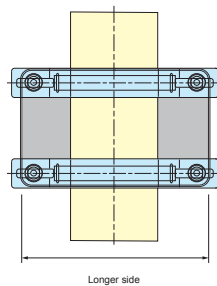

AW series

Box Product no.		SSK Product no.		Screw set Product no.
		Vertical mount	Horizontal mount	
AW	5-4-7	—	SSK-P100	SSK-B4-15N
	5-4-9	—	SSK-P120	SSK-B4-15N
	5-4-11	—	SSK-160	SSK-B4-15N
	5-4-14	—	SSK-200	SSK-B4-15N
	7-7-8	SSK-P50	SSK-P120	SSK-B4-15N
	7-7-11	SSK-P50	SSK-160	SSK-B4-15N
	7-7-15	SSK-P50	SSK-210	SSK-B4-15N
	7-7-20	SSK-P50	SSK-250	SSK-B4-15N
	7-7-25	SSK-P50	SSK-300	SSK-B4-15N
	8-5-9	SSK-P75	SSK-160	SSK-B4-15N
	8-5-12	SSK-P75	SSK-160	SSK-B4-15N
	8-5-14	SSK-P75	SSK-200	SSK-B4-15N
	8-5-18	SSK-P75	SSK-250	SSK-B4-15N
	9-9-10	SSK-P75	SSK-160	SSK-B5-15N
	9-9-13	SSK-P75	SSK-170	SSK-B5-15N
	9-9-17	SSK-P75	SSK-250	SSK-B5-15N
	9-9-22	SSK-P75	SSK-280	SSK-B5-15N
	9-9-28	SSK-P75	SSK-350	SSK-B5-15N
	11-6-11	SSK-P100	SSK-160	SSK-B5-15N
	11-6-15	SSK-P100	SSK-210	SSK-B5-15N
	11-6-19	SSK-P100	SSK-250	SSK-B5-15N
	11-6-24	SSK-P100	SSK-300	SSK-B5-15N
	12-8-11	SSK-P120	SSK-160	SSK-B5-15N
	12-8-14	SSK-P120	SSK-200	SSK-B5-15N
	12-8-17	SSK-P120	SSK-250	SSK-B5-15N
	12-8-22	SSK-P120	SSK-280	SSK-B5-15N
	16-9-14	SSK-160	SSK-200	SSK-B5-15N
	16-9-18	SSK-160	SSK-250	SSK-B5-15N
	16-9-23	SSK-160	SSK-280	SSK-B5-15N
	16-9-28	SSK-160	SSK-350	SSK-B5-15N
	21-9-17	SSK-210	SSK-250	SSK-B5-15N
21-9-21	SSK-210	SSK-280	SSK-B5-15N	
21-9-26	SSK-210	SSK-350	SSK-B5-15N	
21-9-31	SSK-210	SSK-400	SSK-B5-15N	

PKB SERIES

POLE MOUNTING BELT



PKB-10PM, 10P



PKB-10S, 20S

- New shorter belt type PKB-10PM is available for $\phi 25$ to $\phi 60$ mm poles. Other belt types are for $\phi 60$ to $\phi 400$ mm poles.
- Designed for one time use only (not reusable).
- Strong stainless steel clamping type and easy installation plastic type are available.
- Use SSK mounting bracket for installation onto a pole.
- Drawings below are reference examples only. DXF/DWG/PDF drawings available on our website.

PKB dimensions

PKB-10PM, 10P

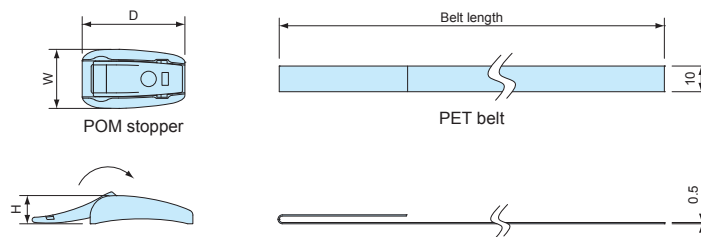

PKB-10S

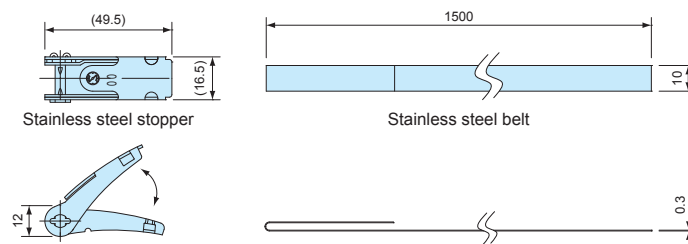

PKB-20S

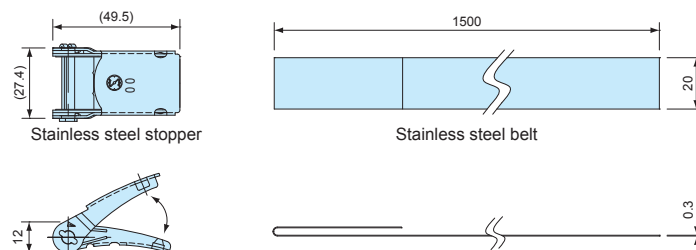

Components

Part name	Pcs	Material	Color / Finish
Stopper	2	POM • Stainless steel SUS304	Black • Barrel finish
Belt	2	PET • Stainless steel SUS430	Gray • Bright Annealed finish

Product no. / Dimensions

Product no.	W	D	H	Belt material	Belt length	Tensile strength (horizontal)	Weight (g)	Pack of
NEW PKB-10PM	24	23	11	PET	500mm	0.8kN	14	2
PKB-10P	23	40	11	PET	1,500mm	1.3kN	31.8	2
PKB-10S	—	—	—	Stainless steel	1,500mm	1.4kN	101.6	2
PKB-20S	—	—	—	Stainless steel	1,500mm	2.9kN	182.2	2

TMA SERIES

DIECAST ALUMINIUM TERMINAL JUNCTION BOX

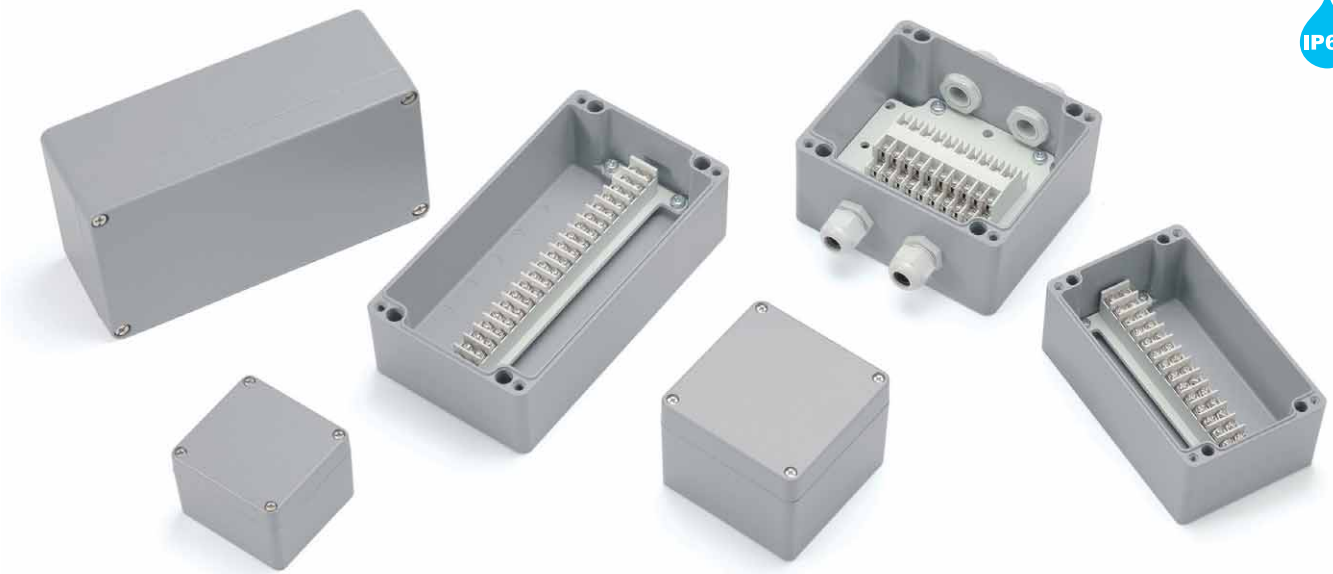

- IP65 protection class and impact resistant diecast aluminium terminal junction box.
- Diecast aluminum box has superior heat dissipation, heat resistance, and oil resistance compared to plastic box.
- Available in 6 different sizes with 6 to 30 poles configurations.

Technical Data
Protection class: IP65
Operating temperature: -40°C ~ +80°C
Recommended torque: 1N • m

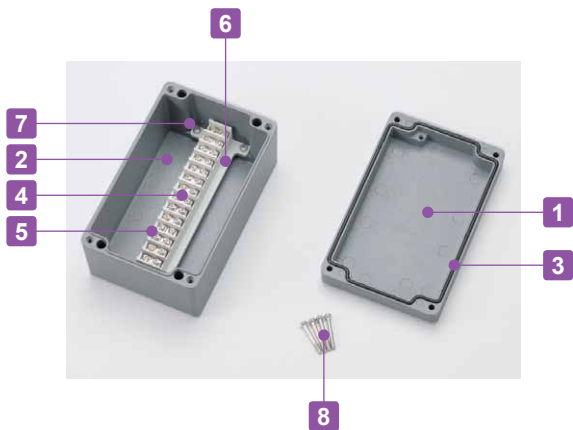

Terminal Block Specification

Rated voltage	400V
Rated current	17.5A
Applicable wire	1.5mm ²
Standard tightening torque	0.8N • m

Applicable crimp terminal R1.25-3.5

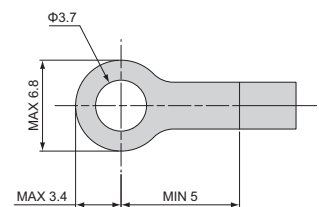

Components

No.	Part name	Pcs	Material	Color / Finish
1	Top cover	1	Diecast aluminium	Light gray / Painted
2	Body	1	Diecast aluminium	Light gray / Painted
3	Gasket	1	Polyurethane	Black
4	Conductive plate	6 ~ 30	Brass	Nickel plated
5	Terminal screw (M3.5 Pan head)	12 ~ 60	Steel	Nickel plated
6	Terminal base	1	PBT (UL94V-0)	Light gray
7	Terminal mount screw (M4 • M6 Pan head)	2 ~ 4	Steel	Trivalent chromate
8	Cover screw	4	Stainless steel	Unfinished

Accessories (Optional parts)



Shorting bar SBR series
See page SBR-1

Cable gland
See cable gland pages

Product no. / Dimensions

Product no.	L	W	H	Number of poles	Weight (g)
TMA- 6P	80	75	57.5	6P	341
TMA- 9P	100	100	80	9P	642
TMA-15P	100	160	80	15P	867
TMA-20P-AS	132	150	90	10P × 2	1,394
TMA-20P	120	220	80	20P	1,426
TMA-30P-AS	120	220	80	15P × 2	1,529

TMA dimensions

■ Drawings below are reference examples only.
DXF/DWG/PDF drawings available on our website.

TMA-6P

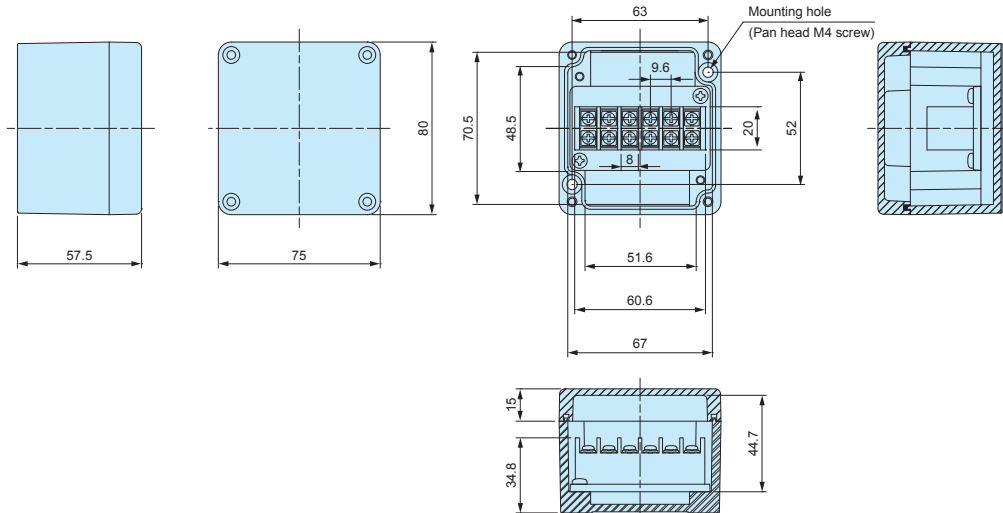

TMA-9P

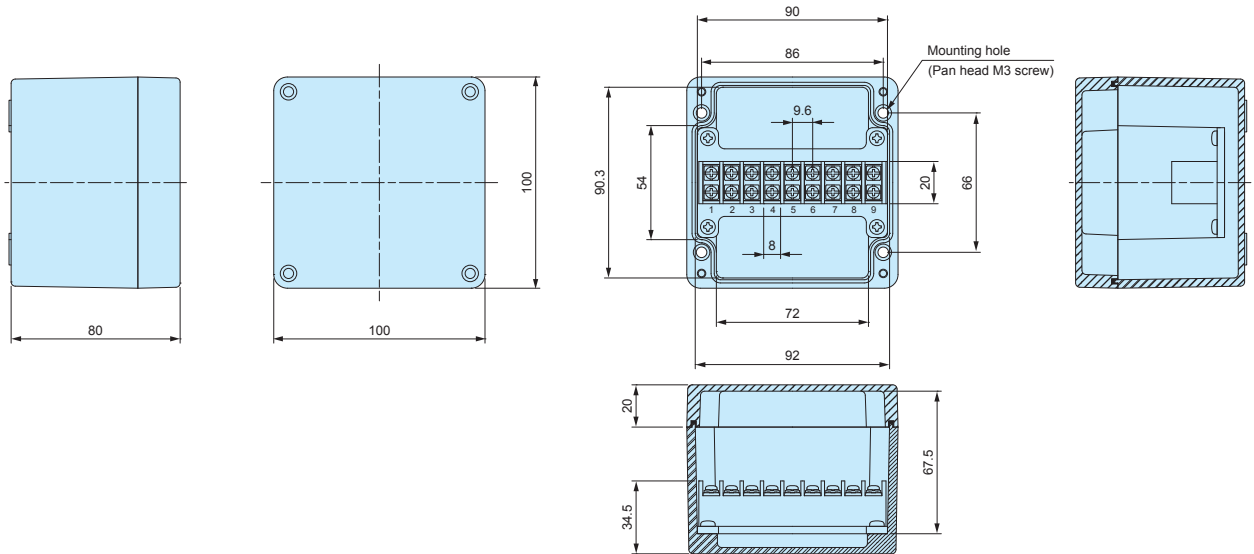

TMA-15P

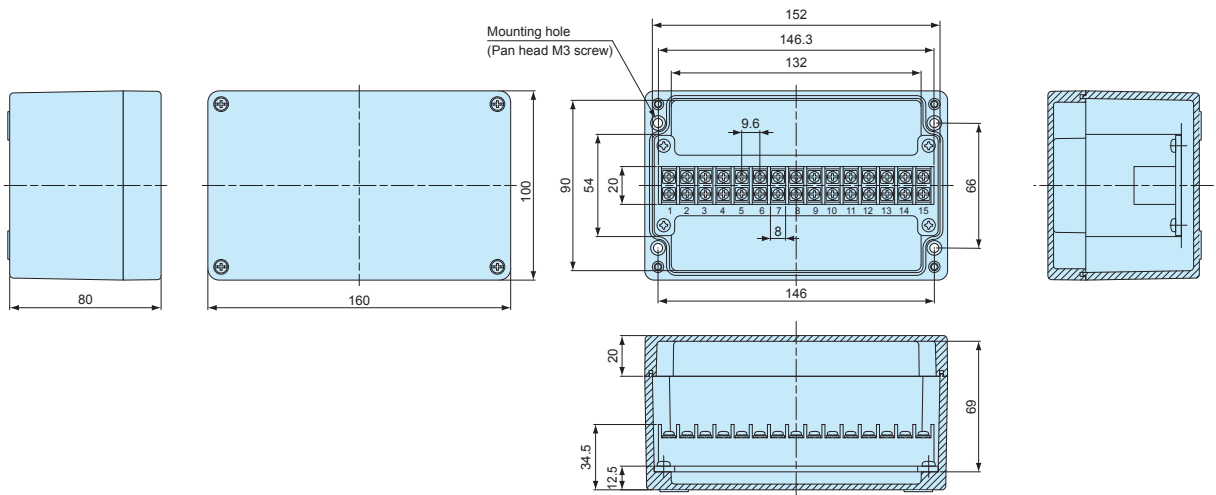

TMA-20P-AS

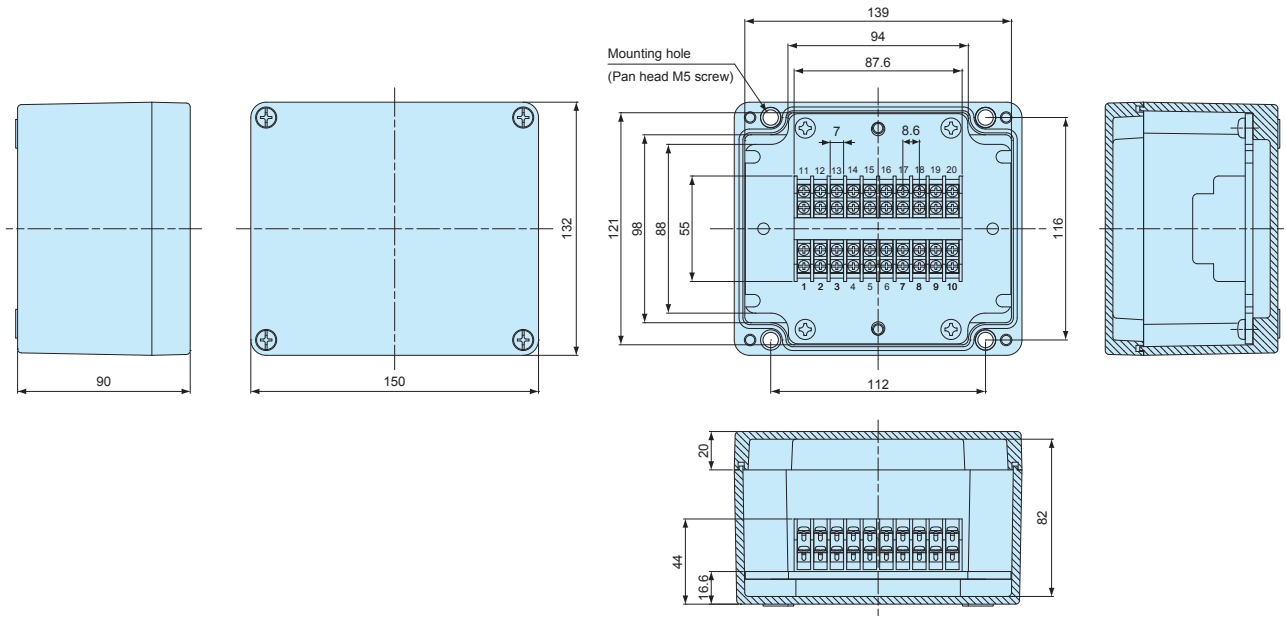

TMA-20P

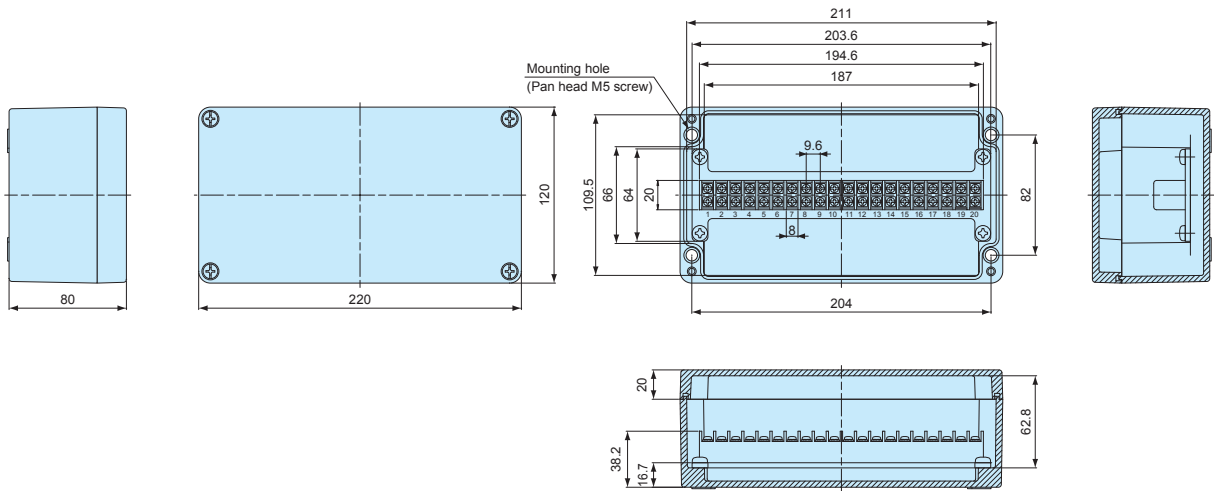

TMA-30P-AS

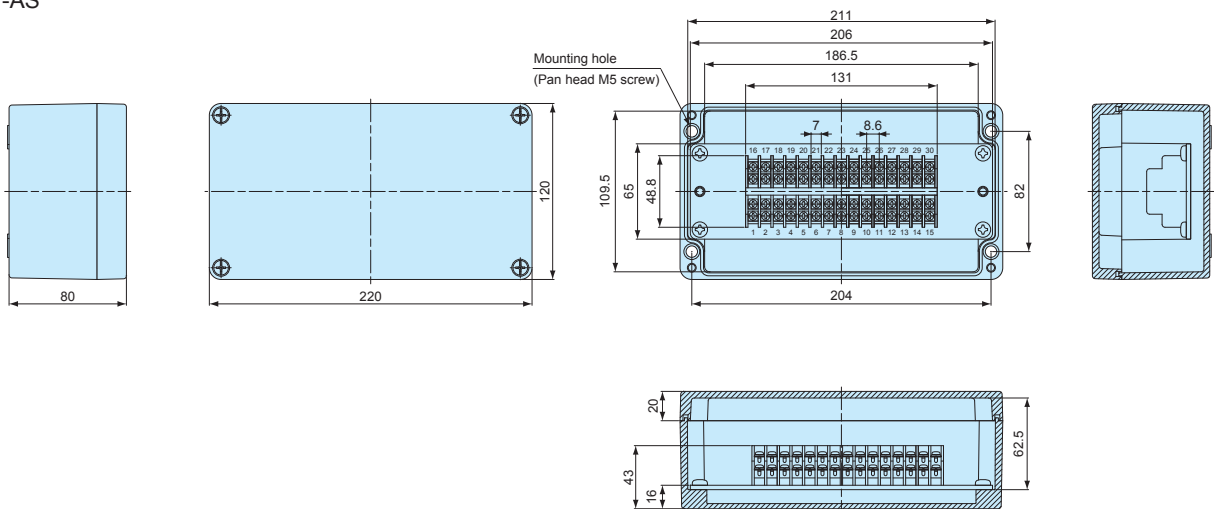

SBR SERIES

SHORTING BAR



- Shorting bar for common-wiring.
- SBR70-10P, SBR85-10P, SBR95-20P, and SBR95-20N can be cut accordingly into required poles.
- PVC coated. SBR95-20 available in both PVC coated (SBR95-20P) and non PVC coated (SBR95-20N) models.
- See chart below for suitable box.

SBR70-2P

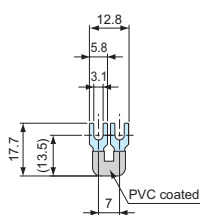

SBR70-10P

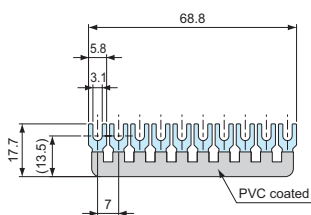

SBR85-2P

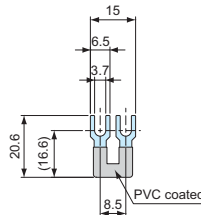

SBR85-10P

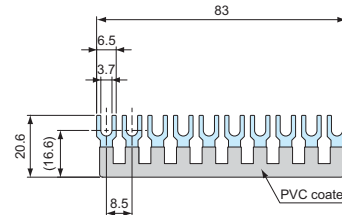

SBR95-20P

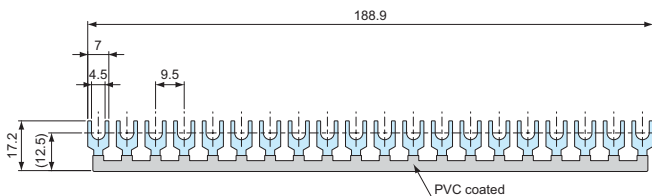

SBR95-20N

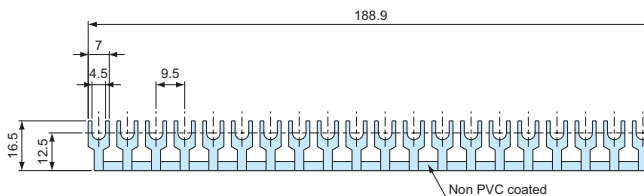

Suitable Box Chart

Product no.	Number of poles	Pole distance	Suitable box
SBR70 - 2P	2P	7.0mm	TMC series
SBR70 -10P	10P	7.0mm	TMC series
SBR85 - 2P	2P	8.6mm	TMB-20P, TMA-20P-AS, TMA30P-AS
SBR85 -10P	10P	8.6mm	TMB-20P, TMA-20P-AS, TMA30P-AS
SBR95 -20P	20P	9.6mm	TMA • TMB series (Not applicable for TMB-20P, TMA20P-AS, and TMA30P-AS models)
SBR95 -20N	20P	9.6mm	TMA • TMB series (Not applicable for TMB-20P, TMA20P-AS, and TMA30P-AS models)

Product no. / Feature

■ Pack quantity differs by models.

Product no.	Number of poles	Material	Finish	PVC coating	Pack of
SBR70 - 2P	2P	Brass	Nickel plated	Yes	10
SBR70 -10P	10P	Brass	Nickel plated	Yes	1
SBR85 - 2P	2P	Brass	Nickel plated	Yes	10
SBR85 -10P	10P	Brass	Nickel plated	Yes	1
SBR95 -20P	20P	Brass	Nickel plated	Yes	1
SBR95 -20N	20P	Brass	Nickel plated	No	1

RB-9

RUBBER BUSH

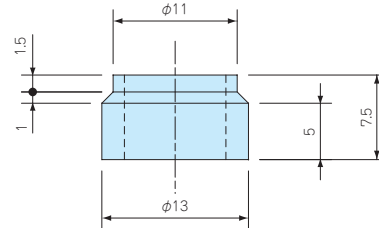
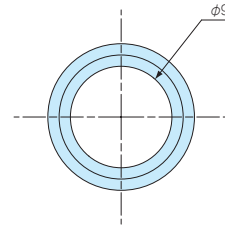

- Rubber bush for TMC series terminal junction box.
- Applicable for $\Phi 8 \sim \Phi 9$ mm diameter cable.

Product no. / Feature

Product no.	Material	Color	Cable range	Pack of
RB-9	NBR	Black	$\Phi 8 \sim \Phi 9$ mm	2

SZ SERIES

WATERPROOF WASHER



- Waterproof washer for screwing onto waterproof boxes.
- NBR sealing material has superior oil resistance (N models only).
- Silicone sealing material has wider operating temperature with superior temperature and water resistance (S models only).

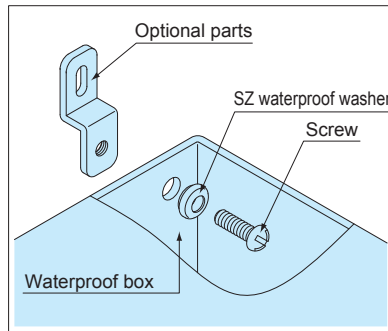
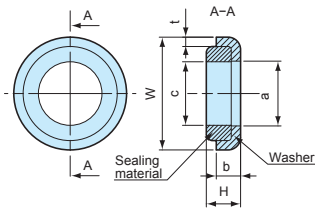

Technical Data

Water pressure resistance:
 M3 ~ M10 : 200kg/cm² 5min
 M12 ~ M16 : 100kg/cm² 5min

- Shape of the sealing material vary by product.

Product no. / Dimensions

Product no.	W	H	a	b	c	t	Washer material	Sealing material	Color	Screw size	Pack of
SZ- 3N	7	2.7	3.2	2.2	3.1	0.5	SUS304	NBR	Black	M 3	1
SZ- 3S	7	2.7	3.2	2.2	3.1	0.5	SUS304	Silicone	Brown	M 3	1
SZ- 4N	8	2.8	4.2	2.1	4.1	0.5	SUS304	NBR	Black	M 4	1
SZ- 4S	8	2.8	4.2	2.1	4.1	0.5	SUS304	Silicone	Brown	M 4	1
SZ- 5N	9.5	3.6	5.2	2.7	5.1	0.8	SUS304	NBR	Black	M 5	1
SZ- 5S	9.5	3.6	5.2	2.7	5.1	0.8	SUS304	Silicone	Brown	M 5	1
SZ- 6N	11.5	4	6.2	3	6.2	1	SUS304	NBR	Black	M 6	1
SZ- 6S	11.5	4	6.2	3	6.2	1	SUS304	Silicone	Brown	M 6	1
SZ- 8N	15.2	3.8	8.2	3.2	8.2	1	SUS304	NBR	Black	M 8	1
SZ- 8S	15.2	3.8	8.2	3.2	8.2	1	SUS304	Silicone	Brown	M 8	1
SZ-10N	18	5.3	10.2	4	10.2	1.5	SUS304	NBR	Black	M10	1
SZ-10S	18	5.3	10.2	4	10.2	1.5	SUS304	Silicone	Brown	M10	1
SZ-12N	24	6.1	14.2	4.8	12.2	1.5	SUS304	NBR	Black	M12	1
SZ-12S	24	6.1	14.2	4.8	12.2	1.5	SUS304	Silicone	Brown	M12	1
SZ-16N	30	6.8	18.4	5.3	16	1.9	SUS304	NBR	Black	M16	1
SZ-16S	30	6.8	18.4	5.3	16	1.9	SUS304	Silicone	Brown	M16	1



- Weatherproof cable gland equipped with high ultraviolet and degradation resistant silicone sealing insert and O-ring.
- Recommended to use outdoors where waterproofing is critical.

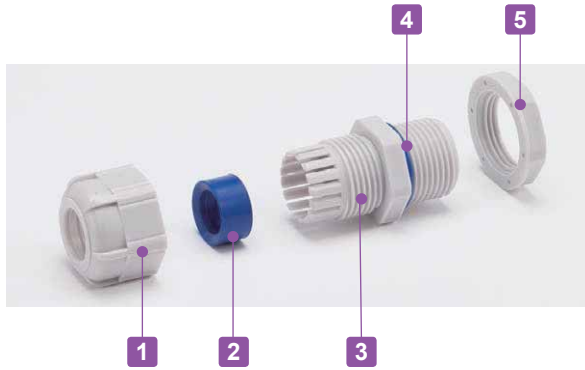

Components

■ PA = Polyamide

No.	Part name	Material
1	Cap	PA66 UL94V-2
2	Sealing insert	Silicone
3	Connector	PA66 UL94V-2
4	O-ring	Silicone
5	Nut	PA66 UL94V-2

RMW dimensions

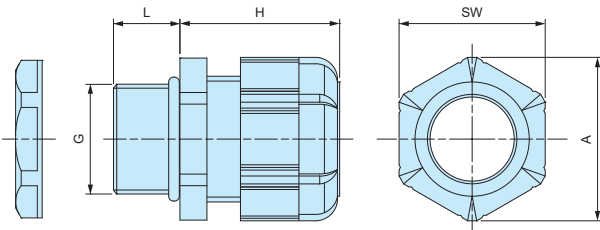

Technical Data

Protection class: IP67
Operating temperature: -20°C ~ +80°C

- DXF/DWG/PDF drawings available on our website.
- Lock nut is not included for RMW10S-6.
Please drill a proper thread hole into the enclosure for installation.

Product no. / Dimensions

Product no.		G		Cable range		L	H Max	SW	A	Pack of
● Black	● Light gray	Thread size	Mounting hole	Min	Max					
RMW8L-2.5B	RMW8L-2.5S	M8×1.25	Φ8.2	1	2.5	13	19.5	11.8	13.5	1
RMW8L-4B	RMW8L-4S	M8×1.25	Φ8.2	2.5	4	13	19.5	11.8	13.5	1
RMW10S-6B	RMW10S-6S	M10×1.5	—	3	6	8	20.5	13	14.4	1
RMW10L-6B	RMW10L-6S	M10×1.5	Φ10.2	3	6	13	20.5	13	14.4	1
RMW12S-7B	RMW12S-7S	M12×1.5	Φ12.2	3.5	7	9	20.5	16	17.6	1
RMW12L-7B	RMW12L-7S	M12×1.5	Φ12.2	3.5	7	14.5	20.5	16	17.7	1
RMW16S-8B	RMW16S-8S	M16×1.5	Φ16.2	4	8	9	23.5	19	21	1
RMW16L-8B	RMW16L-8S	M16×1.5	Φ16.2	4	8	15	24	19	21	1
RMW20S-12B	RMW20S-12S	M20×1.5	Φ20.2	6	12	10	29	24	26.2	1
RMW20L-12B	RMW20L-12S	M20×1.5	Φ20.2	6	12	15	28.5	24	26.2	1
RMW25L-17B	RMW25L-17S	M25×1.5	Φ25.2	11	17	15	35	33	36.2	1
RMW32L-21B	RMW32L-21S	M32×1.5	Φ32.3	13	21	15	38	36	39.5	1
RMW40L-27B	RMW40L-27S	M40×1.5	Φ40.3	18	27	18	43.5	45.7	50.5	1
RMW50L-38B	RMW50L-38S	M50×1.5	Φ50.4	27	38	20	50.5	60	66.5	1
RMW8L-2.5B-P	RMW8L-2.5S-P	M8×1.25	Φ 8.2	1	2.5	13	19.5	11.8	13.5	100
RMW8L-4B-P	RMW8L-4S-P	M8×1.25	Φ 8.2	2.5	4	13	19.5	11.8	13.5	100
RMW10L-6B-P	RMW10L-6S-P	M10×1.5	Φ10.2	3	6	13	20.5	13	14.4	100
RMW12S-7B-P	RMW12S-7S-P	M12×1.5	Φ12.2	3.5	7	9	20.5	16	17.6	100
RMW12L-7B-P	RMW12L-7S-P	M12×1.5	Φ12.2	3.5	7	14.5	20.5	16	17.7	100
RMW16S-8B-P	RMW16S-8S-P	M16×1.5	Φ16.2	4	8	9	23.5	19	21	100
RMW16L-8B-P	RMW16L-8S-P	M16×1.5	Φ16.2	4	8	15	24	19	21	100
RMW20S-12B-P	RMW20S-12S-P	M20×1.5	Φ20.2	6	12	10	29	24	26.2	100
RMW20L-12B-P	RMW20L-12S-P	M20×1.5	Φ20.2	6	12	15	28.5	24	26.2	100
RMW25L-17B-P	RMW25L-17S-P	M25×1.5	Φ25.2	11	17	15	35	33	36.2	100

RMW series silicone sealing insert weatherproof test report

Object: Cut into a piece of the silicone sealing insert from RMW series and attach it onto an aluminium plate.
 For comparison, NBR sealing insert from our RM and EPDM sealing insert from another manufacturer is also attached for comparison purposes.

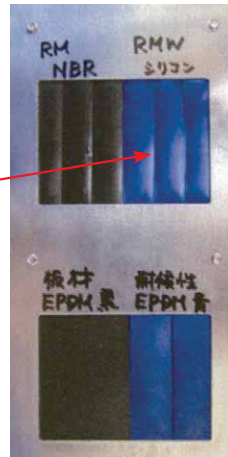

Before

After

Testing conditions

Equipment : 7.5kW Super Xenon Weather Meter SX75 (Suga Test Instruments Co., Ltd.- <http://www.sugatest.co.jp/english/>)
Conditions : JIS B7754 : 1991

Testing with an authorized Xenon arc lamp weathering test equipment under the conditions denoted below.

Irradiance : 180W/m² at 300-400nm

Black Panel Temperature : 63±3°C Humidity Range : 50±10%

Cycle Conditions : 120 minutes cycle (18 minutes irradiation + water spray - 102 minutes irradiation)

2,000 hours (equivalent to a period of 4 years under natural conditions)

Time period :

Total radiant exposure : 1296MJ/m²

Test result (visual / touch inspection)

Silicone sealing insert material : No cracks, no gloss transition, no powder - no appearance change at all. Flexibility remains unchanged.

Before



After



NBR material from our RM series : Lost glossiness on the surface and material is stiffened.

Before



After



EPDM material from weatherproof cable gland of another manufacturer : Cracked, color drastically faded and powder appeared on the surface.

Before

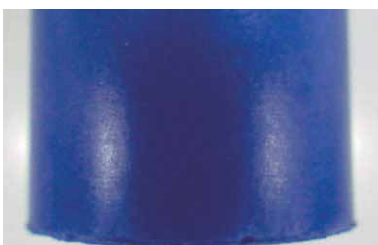

After

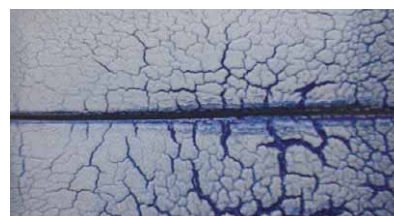

RM SERIES

POLYAMIDE CABLE GLAND

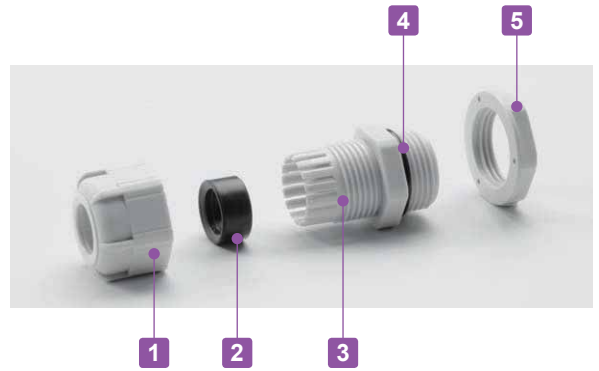

- Low cost cable glands made from polyamide material.
- Wide selection, for M8 ~ M63, suitable for $\Phi 1\text{mm} \sim \Phi 44\text{ mm}$ cable.
- High oil resistant NBR rubber sealing and O-ring.
- IP67 protection class.

Components

■ PA = Polyamide

No.	Part name	Material
1	Cap	PA66 UL94V-2
2	Sealing insert	NBR
3	Connector	PA66 UL94V-2
4	O-ring	NBR
5	Lock nut	PA66 UL94V-2

RM dimensions

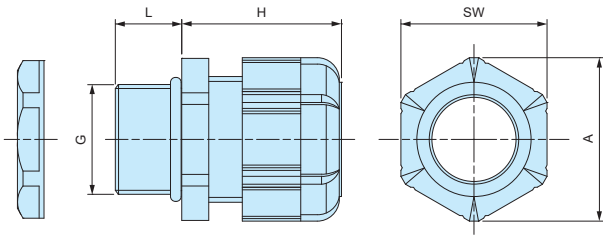

Technical Data

Protection class: IP67
Operating temperature: $-20^{\circ}\text{C} \sim +80^{\circ}\text{C}$

- DXF/DWG/PDF drawings available on our website.
- Lock nut is not included for RM8S-2.5, 8S-4, and 10S-6 models.
Please drill a proper thread hole into the enclosure for installation.

Product no. / Dimensions

Product no.		G		Cable range		L	H Max	SW	A	Pack of
● Black	● Light gray	Thread size	Mounting hole	Min	Max					
RM8S-2.5B	RM8S-2.5S	M8×1.25	—	1	2.5	7.5	19.5	11.8	13.5	1
RM8L-2.5B	RM8L-2.5S	M8×1.25	$\Phi 8.2$	1	2.5	13	19.5	11.8	13.5	1
RM8S-4B	RM8S-4S	M8×1.25	—	2.5	4	7.5	19.5	11.8	13.5	1
RM8L-4B	RM8L-4S	M8×1.25	$\Phi 8.2$	2.5	4	13	19.5	11.8	13.5	1
RM10S-6B	RM10S-6S	M10×1.5	—	3	6	8	20.5	13	14.4	1
RM10L-6B	RM10L-6S	M10×1.5	$\Phi 10.2$	3	6	13	20.5	13	14.4	1
RM12S-7B	RM12S-7S	M12×1.5	$\Phi 12.2$	3.5	7	9	20.5	16	17.6	1
RM12L-7B	RM12L-7S	M12×1.5	$\Phi 12.2$	3.5	7	14.5	20.5	16	17.7	1
RM16S-8B	RM16S-8S	M16×1.5	$\Phi 16.2$	4	8	9	23.5	19	21	1
RM16L-8B	RM16L-8S	M16×1.5	$\Phi 16.2$	4	8	15	24	19	21	1
RM20S-12B	RM20S-12S	M20×1.5	$\Phi 20.2$	6	12	10	29	24	26.2	1
RM20L-12B	RM20L-12S	M20×1.5	$\Phi 20.2$	6	12	15	28.5	24	26.2	1
RM25L-17B	RM25L-17S	M25×1.5	$\Phi 25.2$	11	17	15	35	33	36.2	1
RM32L-21B	RM32L-21S	M32×1.5	$\Phi 32.3$	13	21	15	38	36	39.5	1
RM40L-27B	RM40L-27S	M40×1.5	$\Phi 40.3$	18	27	18	43.5	45.7	50.5	1
RM50L-38B	RM50L-38S	M50×1.5	$\Phi 50.4$	27	38	20	50.5	60	66.5	1
RM63L-44B	RM63L-44S	M63×1.5	$\Phi 63.4$	37	44	20	53	68	75.5	1
RM8L-2.5B-P	RM8L-2.5S-P	M8×1.25	$\Phi 8.2$	1	2.5	13	19.5	11.8	13.5	100
RM8L-4B-P	RM8L-4S-P	M8×1.25	$\Phi 8.2$	2.5	4	13	19.5	11.8	13.5	100
RM10L-6B-P	RM10L-6S-P	M10×1.5	$\Phi 10.2$	3	6	13	20.5	13	14.4	100
RM12S-7B-P	RM12S-7S-P	M12×1.5	$\Phi 12.2$	3.5	7	9	20.5	16	17.6	100
RM12L-7B-P	RM12L-7S-P	M12×1.5	$\Phi 12.2$	3.5	7	14.5	20.5	16	17.7	100
RM16S-8B-P	RM16S-8S-P	M16×1.5	$\Phi 16.2$	4	8	9	23.5	19	21	100
RM16L-8B-P	RM16L-8S-P	M16×1.5	$\Phi 16.2$	4	8	15	24	19	21	100
RM20S-12B-P	RM20S-12S-P	M20×1.5	$\Phi 20.2$	6	12	10	29	24	26.2	100
RM20L-12B-P	RM20L-12S-P	M20×1.5	$\Phi 20.2$	6	12	15	28.5	24	26.2	100
RM25L-17B-P	RM25L-17S-P	M25×1.5	$\Phi 25.2$	11	17	15	35	33	36.2	100

RPG SERIES

POLYAMIDE CABLE GLAND



IP67

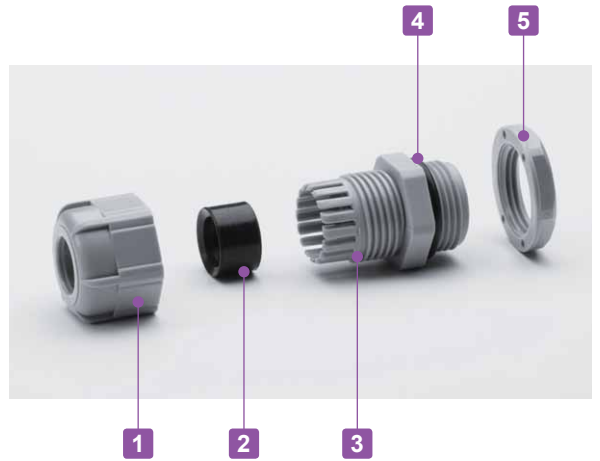

- Inexpensive cable glands made from polyamide material with PG threading.
- High oil resistant NBR rubber sealing and O-ring.
- IP67 protection class.

RPG dimensions

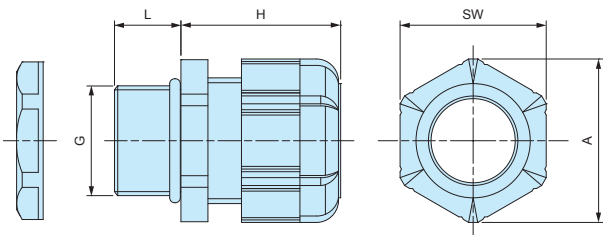

■ DXF/DWG/PDF drawings available on our website.

Components

■ PA = Polyamide

No.	Part name	Material
1	Cap	PA66 UL94V-2
2	Sealing insert	NBR
3	Connector	PA66 UL94V-2
4	O-Ring	NBR
5	Lock-nut	PA66 UL94V-2

Technical Data

Protection class: IP67
Operating temperature: -20°C ~ +80°C

Product no. / Dimensions

Product no.		G			Cable range		L	H Max	SW	A	Pack of
● Black	● Gray	Thread size	Thread dia.	Mounting hole	Min	Max					
RPG7-7B	RPG7-7G	PG7	12.5	Φ12.7	3	7	9	20.5	16	17.7	1
RPG9-8B	RPG9-8G	PG9	15.2	Φ15.4	4	8	9	23.5	19	21	1
RPG11-10B	RPG11-10G	PG11	18.6	Φ18.8	5	10	9	26	22	24	1
RPG13.5-11B	RPG13.5-11G	PG13.5	20.4	Φ20.6	6	11	10	29	24	26.4	1
RPG16-14B	RPG16-14G	PG16	22.5	Φ22.7	8	14	10	30	26.7	29.5	1
RPG21-18B	RPG21-18G	PG21	28.3	Φ28.5	13	18	12	35	33	36.5	1
RPG29-25B	RPG29-25G	PG29	37	Φ37.2	18	25	12	41.5	42	46.5	1

SP SERIES

SEALING PLUG



SP dimensions

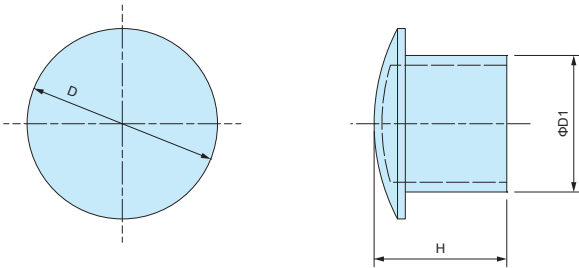

■ Material : Nylon

- Sealing plug for cable glands when not in use.
- Maintain a waterproof seal when plugged into the sealing insert on cable glands.

Product no. / Dimensions

Product no.	D	D1	H	Suitable cable glands	Pack of
SP-12	10.2	6	15.5	RMW12, RM12, RMW16, RM16, RPG7, RPG9	10
SP-16	15.6	9.5	15.5	RMW20, RM20, RPG11, RPG13.5	10
SP-20	19.6	13.5	16.5	RPG16	10
SP-25	24.4	17.5	17	RMW25, RM25, RMW32, RM32, RPG21	5
SP-40	32.5	24.5	17.5	RMW40, RM40, RPG29	5
SP-50	47.2	38.9	17.6	RMW50, RM50	5



- High water protection IP68 (1bar / 30min) polyamide cable gland.
- Wide selection, for M8 ~ M50, suitable for $\Phi 2.5\text{mm} \sim \Phi 42\text{mm}$ cable.
- Super tough and superior heat resistant PA6GF (glass fiber filled PA6) material on cap and connector.
- Safer halogen free, eco-friendly product.

Technical Data
Protection class: IP68 1bar / 30min
Operating temperature: -20°C ~ +100°C
Compliant with EN50262 Ver. A

AG Series

Thicker sealing insert evenly hold a cable by having a larger holding area.
Remains durable even after repeated tightening / loosening.

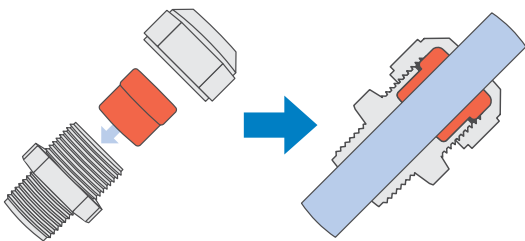

Lamellar insert type

If over-tightened, it can cause the rubber bush or cable to deform, which can allow water to seep in.

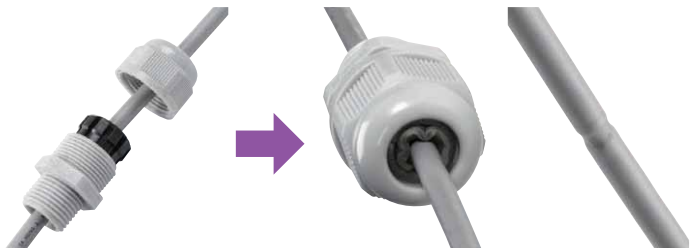

Components

■ PA6GF = Polyamide6 Glass Fiber Filled

No.	Part name	Material
1	Cap	PA6GF
2	Sealing insert	TPE
3	Connector	PA6GF
4	Lock nut	PA6

- Lock nut is not included for M8 and M10 sizes.
Please drill a proper thread hole into the enclosure for installation.

- Proper tightening torque varies by each cable diameter.
Tighten the cap until top of the sealing insert forms a small bead between the cap and the cable.



- No optional sealing washer is required when installing on an even surface because of the built-in waterproof rib.
- An optional sealing washer is required when installing on an uneven surface. (See page AGP-1 for more information on the optional sealing washer)

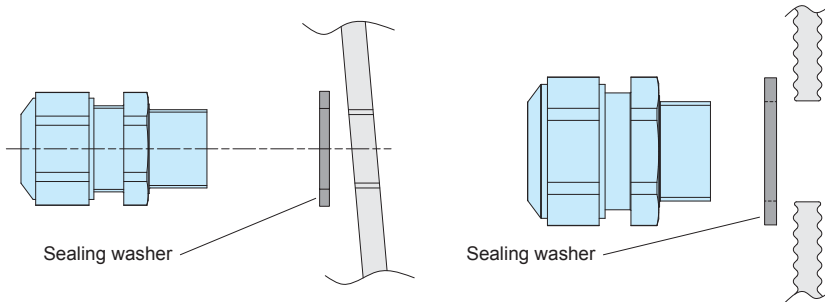

AG dimensions

- DXF/DWG/PDF drawings available on our website.

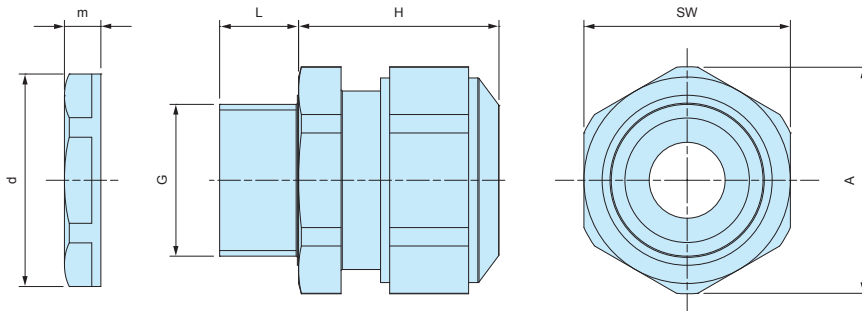

- Lock nut is not included for M8 and M10 sizes. Please drill a proper thread hole into the enclosure for installation.

Product no. / Dimensions

Product no.		G		Cable range		L	H Max	SW	A	d	m	Pack of
● Black	● Light gray	Thread size	Mounting hole	Min	Max							
AG8-3.5B	AG8-3.5S	M8×1.0	—	2.5	3.5	10	17	12	13.2	—	—	1
AG8-5B	AG8-5S	M8×1.0	—	3.5	4.7	10	17	12	13.2	—	—	1
AG10-6B	AG10-6S	M10×1.0	—	4	6	10	19	15	16.5	—	—	1
AG12-5B	AG12-5S	M12×1.5	Φ12.2	3.5	4.7	12	23.5	17	18.7	18.8	5	1
AG12-6.5B	AG12-6.5S	M12×1.5	Φ12.2	5	6.5	12	23	17	18.7	18.8	5	1
AG12-8B	AG12-8S	M12×1.5	Φ12.2	6.5	7.8	12	23	17	18.7	18.8	5	1
AG16-10B	AG16-10S	M16×1.5	Φ16.2	8	10	12	26	21	23.1	24.3	5	1
AG20-15B	AG20-15S	M20×1.5	Φ20.2	11	15	13	27	27	29.7	29	6	1
AG25-16B	AG25-16S	M25×1.5	Φ25.2	12.5	16	13	34	34	37.4	36	6.7	1
AG25-20B	AG25-20S	M25×1.5	Φ25.2	16	20	13	34	34	37.4	36	6.7	1
AG32-25.5B	AG32-25.5S	M32×1.5	Φ32.3	21	25.5	15	36	41	45.6	46	8	1
AG40-28.5B	AG40-28.5S	M40×1.5	Φ40.3	24	28.5	15	41	50	55.4	53.5	9	1
AG40-33B	AG40-33S	M40×1.5	Φ40.3	28.5	33	15	41	50	55.4	53.5	9	1
AG50-37B	AG50-37S	M50×1.5	Φ50.4	33	37	16	45	60	65.5	66	9.6	1
AG50-42B	AG50-42S	M50×1.5	Φ50.4	37	42	16	45	60	65.5	66	9.6	1

AGP SERIES

SEALING WASHER for AG • AGSP



- Sealing washer for AG series.
- Made from oil resistant NBR material.
- Use in the case of installation on a rough or uneven surfaces.
- Selectable in 7 sizes (from M12 to M50)
- Sealing washer is not necessary for installation on flat surfaces.

AGP Dimensions

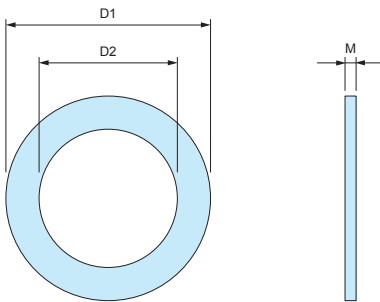

- Material : NBR

Product no. / Dimensions

Product no.	D1	D2	M	Suitable cable gland	Pack of
AGP-12	20	12	1.6	AG12	10
AGP-16	23.5	16.5	2.0	AG16	10
AGP-20	29	20	2.0	AG20	10
AGP-25	37	25	2.0	AG25	10
AGP-32	44	32	2.2	AG32	5
AGP-40	52	40	2.2	AG40	5
AGP-50	64	50	3.1	AG50	5

RSP SERIES

STRAIN RELIEF CABLE GLAND



■ DXF/DWG/PDF drawings available on our website.

Technical Data
Protection class : IP67 Temperature range -20°C ~ +80°C

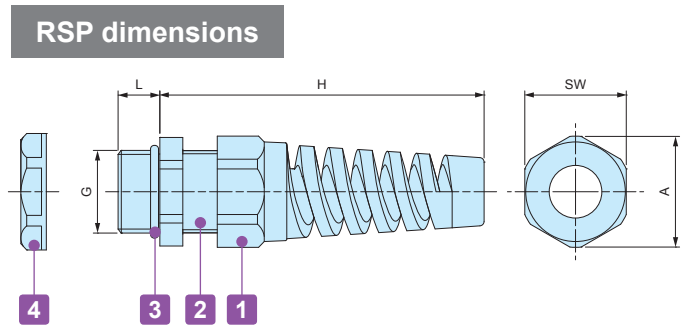

Components

■ PA = Polyamide

No.	Part name	Material
1	Strain relief cap	PA66 (UL94V-2)
-	Sealing insert	NBR
2	Connector	PA66 (UL94V-2)
3	O-ring	NBR
4	Lock- nut	PA66 (UL94V-2)

Product no. / Dimensions

Product no.		G		Cable range		L	H Max	SW	A	Pack of
● Black	● Light gray	Thread size	Mounting hole	Min	Max					
RSP12-6B	RSP12-6S	M12×1.5	φ12.2	3.5	6	9	62	16	17	1
RSP16-8B	RSP16-8S	M16×1.5	φ16.2	4	8	9	69	19.5	21	1
RSP20-11B	RSP20-11S	M20×1.5	φ20.2	6	11	10	82	24	26	1
RSP25-16B	RSP25-16S	M25×1.5	φ25.2	11	16	12	102	33	36	1

AGM SERIES

METAL CABLE GLAND

IP68



- High water protection IP68 (1bar / 30min) metal cable gland.
- Wide selection, for M6 ~ M50 and PG7 ~ PG16.
Suitable for $\Phi 2$ mm ~ $\Phi 42$ mm cable.

Technical Data
Protection class: IP68 1bar / 30min
Operating temperature: -40°C ~ +100°C
Compliant with EN50262 Ver. A

AGM Series

Thicker sealing insert evenly hold a cable by having a larger holding area. Remains durable even after repeated tightening / loosening.

Lamellar insert type

If over-tightened, it can cause the rubber bush or cable to deform, which can allow water to seep in.

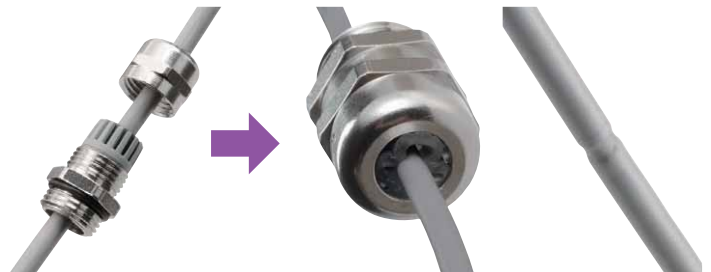
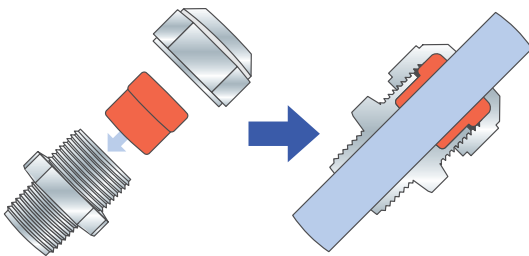

- Proper tightening torque varies by each cable diameter.
Tighten the cap until top of the sealing insert forms a small bead between the cap and the cable.



Components

No.	Part name	Material	Color / Finish
1	Cap	Brass	Nickel plated
2	Sealing insert	TPE	Black
3	Connector	Brass	Nickel plated
-	O-ring	NBR	Black
4	Lock nut	Brass	Nickel plated

AGM dimensions

■ DXF/DWG/PDF drawings available on our website.

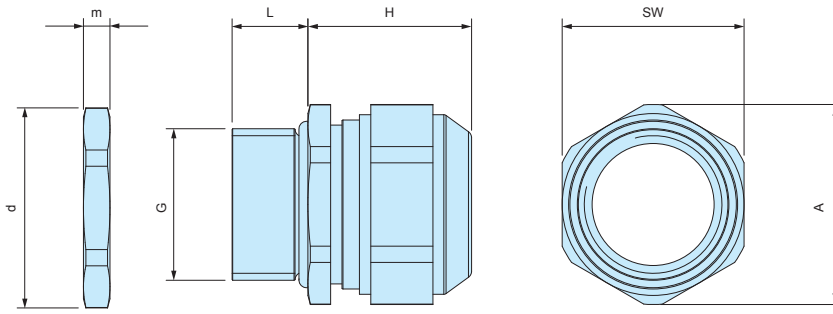

Product no. / Dimensions

Product no.	G			Cable range		L	H Max	SW	A	d	m	Pack of
	Thread size	Thread outer dia.	Mounting hole	Min	Max							
AGM6-2.5	M6×1.0	—	Φ6.2	2	2.5	8	12	8	9	10	2.8	1
AGM6-3	M6×1.0	—	Φ6.2	2.5	3.0	8	12	8	9	10	2.8	1
AGM6-3.5	M6×1.0	—	Φ6.2	3.0	3.5	8	12	8	9	10	2.8	1
AGM8-5	M8×1.25	—	Φ8.2	3.5	4.7	10	14	11	12	12	3	1
AGM10-6	M10×1.5	—	Φ10.2	4.0	6.0	10	15	13	14.3	14	2.8	1
AGM12-8	M12×1.5	—	Φ12.2	6.5	8.0	10	17	15	16.5	16.5	2.8	1
AGM16-10.5	M16×1.5	—	Φ16.2	8.0	10.5	10	21	18	20	21	3	1
AGM20-15	M20×1.5	—	Φ20.2	11.0	15.0	10	23	24	26.5	26.5	3.5	1
AGM25-20	M25×1.5	—	Φ25.2	16.0	20.0	11	28	30	33	33	4	1
AGM32-25.5	M32×1.5	—	Φ32.3	21.0	25.5	13	29.5	36	39.5	39.5	4	1
AGM40-28.5	M40×1.5	—	Φ40.3	24.0	28.5	13	32	46	50.7	51	5	1
AGM40-33	M40×1.5	—	Φ40.3	28.5	33.0	13	32	46	50.7	51	5	1
AGM50-37	M50×1.5	—	Φ50.4	33.0	37.0	14	34	55	59.7	60	5.5	1
AGM50-42	M50×1.5	—	Φ50.4	37.0	42.0	14	34	55	59.7	60	5.5	1
AGM7PG-5	PG7	12.5	Φ12.7	3.5	5.0	6	17	15	16.5	16.5	3	1
AGM9PG-6	PG9	15.2	Φ15.4	4.5	6.0	6	20	18	20	20	3	1
AGM11PG-8.5	PG11	18.6	Φ18.8	5.5	8.5	6	21	21	23	23.5	3	1
AGM13PG-11	PG13	20.4	Φ20.6	8.0	11.0	6	21	24	26.5	25.5	3	1
AGM16PG-14.5	PG16	22.5	Φ22.7	11	14.5	6	23	24	26.5	29	3	1

AGE SERIES

EMC SHIELDED CABLE GLAND



- Optimal contact spring provides excellent shield contact and the smallest possible transfer impedance.
- Clawed lock nut makes a good EMC shield contact possible on conductive enclosures.
- Shape of the contact spring not only allows for a large clamping range to the shield but also enables easy and faster installation and re-installation.
- 2-piece detachable sealing inserts can be adapted to the wider existing cable diameter on site.
(AGE12 available only with 1-piece sealing insert)

Technical Data	
Protection class :	IP68 2bar / 30min, IP69K
	20m depth immersion in 30 minutes
Operating temperature :	-60°C ~ +100°C
	Compliant with IEC62444 Var. A

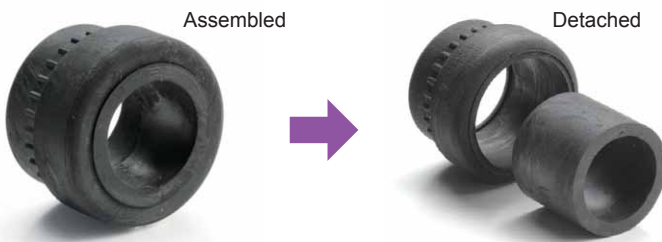

Cable Range

No.	Sealing insert type	
	Assembled	Detached
AGE16-10.5	Φ 6 ~ Φ 7.5	Φ 7.5 ~ Φ10.5
AGE20-15	Φ 8 ~ Φ10.5	Φ10.5 ~ Φ15
AGE25-20	Φ12.5 ~ Φ15	Φ15 ~ Φ20
AGE32-25	Φ17 ~ Φ20	Φ20 ~ Φ25

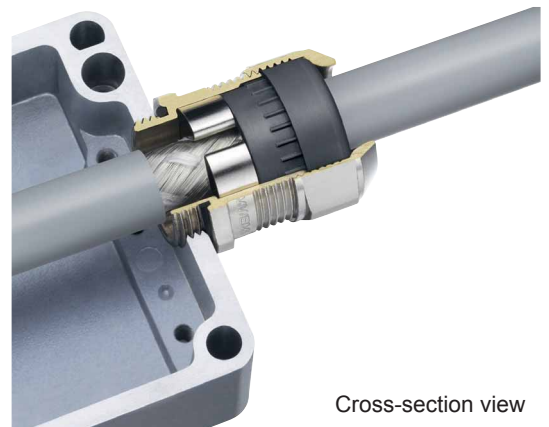
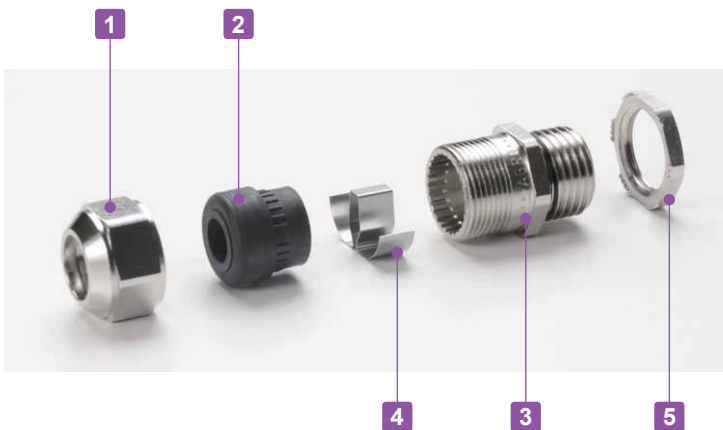

Cross-section view

Components

No.	Part name	Material	Color / Finish
1	Cap	Brass	Nickel plated
2	Sealing insert	TPE	Black
3	Connector	Brass	Nickel plated
4	Contact spring	Stainless steel	Unfinished
-	O-Ring	NBR	Black
5	Lock-nut	Brass	Nickel plated

INSTALLATION Instruction

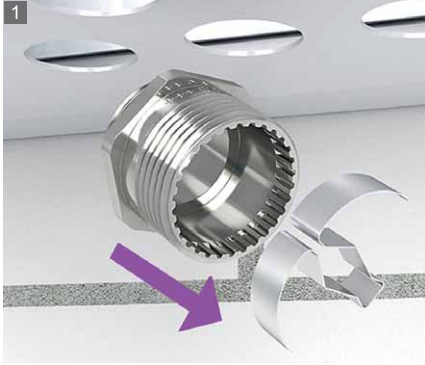

1 Remove the contact spring from the connector.



2 Install the connector onto the enclosure.



3 Strip the cable.

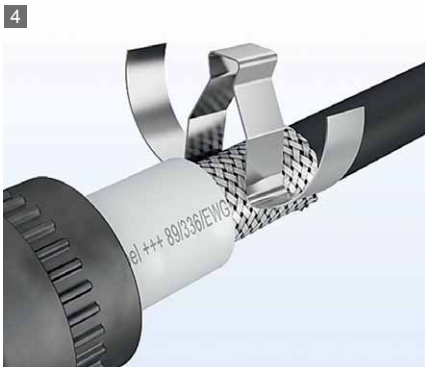

4 Clip the contact spring on the shielded cable.



5 Pass the cable through the Sealing insert and cap.



6 Tighten the cap to complete.

AGE dimensions

■ DXF/DWG/PDF drawings available on our website.

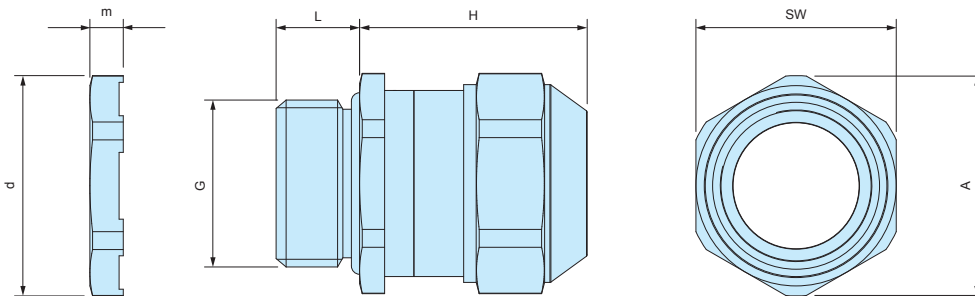

Product no. / Dimensions

Product no.	G		Cable range		L	H Max	SW	A	d	m	Pack of
	Thread size	Mounting hole	Min	Max							
AGE12-5	M12×1.5	Φ12.2	3.5	5.0	10	22	15	16.5	16.5	3.5	1
AGE12-6.5	M12×1.5	Φ12.2	5.0	6.5	10	22	15	16.5	16.5	3.5	1
AGE16-10.5	M16×1.5	Φ16.2	6.0	10.5	10	25	18	20	21	3.5	1
AGE20-15	M20×1.5	Φ20.2	8.0	15.0	10	27	24	26.5	26.5	4	1
AGE25-20	M25×1.5	Φ25.2	12.5	20.0	11	33	30	33	33	4	1
AGE32-25	M32×1.5	Φ32.3	17.0	25.0	13	34	36	39.5	39.5	5	1

AGH SERIES

HEAT RESISTANT METAL CABLE GLAND



- Heat resistant sealing insert made of FPM material. Resistant up to 200°C
- IP68 1bar / 30min high performance waterproof cable gland.

Technical Data
Protection class : Protection class IP68 1bar / 30min 10m depth immersion in 30 minutes
Operating temperature : -40°C ~ +200°C
Compliant with EN50262 Var. A

AGH series

Thicker sealing insert evenly clasp onto the cable by having a larger area. Remains durable even after repeated tightening / loosening.

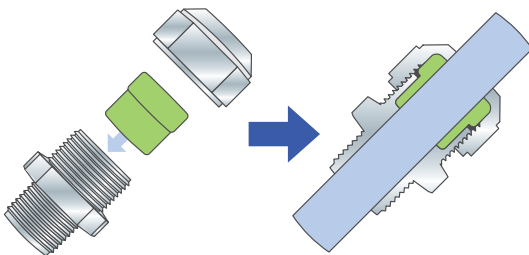

Conventional cable gland

If over-tightened, it can cause the rubber bush or cable to deform, which may allow water to seep in.

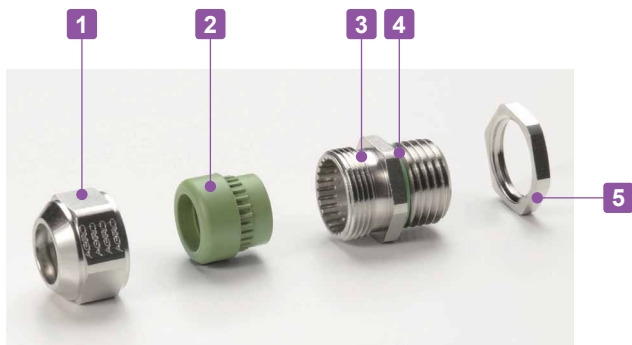
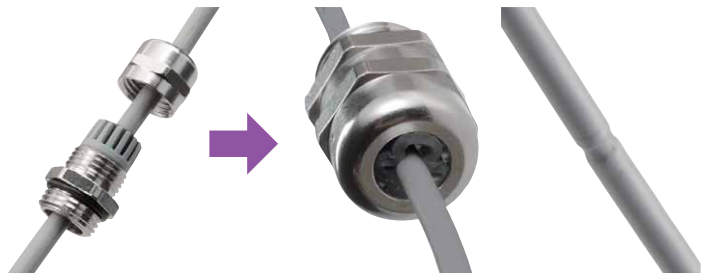

- Tightening torque varies depending on the cable diameter. Tighten until the sealing insert protrudes slightly from the cap.



Components

No.	Part name	Material	Color / Finish
1	Cap	Brass	Nickel plated
2	Sealing insert	FPM	Green
3	Connector	Brass	Nickel plated
4	O-Ring	FPM	Green
5	Lock-nut	Brass	Nickel plated

AGH dimensions

■ DXF/DWG/PDF drawings available on our website.

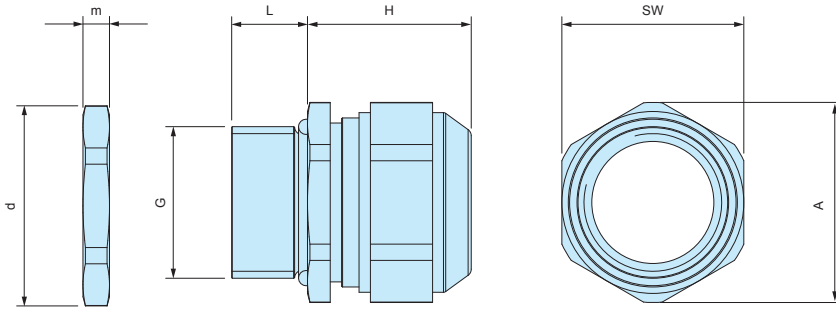

Product no. / Dimensions

Product no.	G		Cable range		L	H Max	SW	A	d	m	Pack of
	Thread size	Mounting hole	Min	Max							
AGH10-6	M10×1.5	Φ10.2	4.0	6.0	10	15	13	14.3	14.2	3	1
AGH12-8	M12×1.5	Φ12.2	6.5	8.0	10	17	15	16.5	16.5	3	1
AGH16-10.5	M16×1.5	Φ16.2	8.0	10.5	10	20	18	20	21	3	1
AGH20-15	M20×1.5	Φ20.2	11.0	15.0	10	23	24	26.5	26.3	3.5	1
AGH25-20	M25×1.5	Φ25.2	16.0	20.0	11	27	30	33	33	4	1
AGH32-25.5	M32×1.5	Φ32.3	21.0	25.5	13	28.5	36	39.7	39.7	4	1

PMF-6B

SMALL PROTECTIVE VENT



Application example

- Small and screw-in protective vent suitable for compact, and hand-held type devices.
- IP68 protection class (water depth 2 meters / 60 mins) and -40°C ~ +150°C operating temperature range allows it to be used in various environments.
- Suitable for enclosures with capacities of 2.0 litres or under.
- For outdoor use, installation on the side of the enclosure unit is recommended.

PMF-6B dimensions

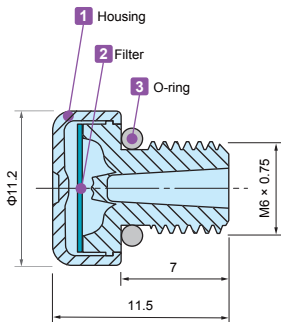

Hole milling drawings

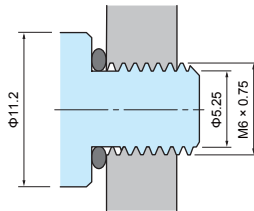

Installation drawings

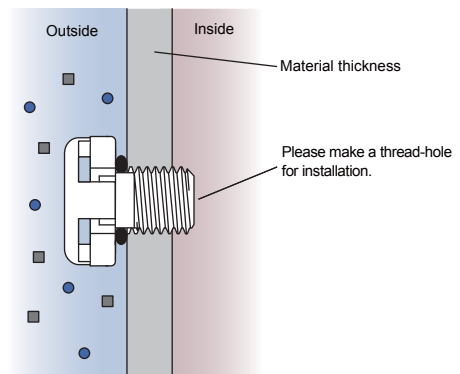

Technical Data

Airflow	300ml / min (dp = 7 kPa)
Recommended Torque	0.2 ~ 0.4 N • m
Certifications	IEC60529 (Protection class test) : IP66 • IP67 • IP68 IEC60068-2-1, 2, 14 (Heat resistance test) : -40°C ~ +150°C IEC60068-2-78 (Humidity test) : 85°C • 85% humidity • 1000 hours IEC60068-2-64 (Vibration test) UL94V-0 (Flame-resistant) • UL746C f1

Product no. / Dimensions

Product no.	Material			G	
● Black	1 Housing	2 Filter	3 O-ring	Thread size	Mount hole
PMF-6B	PA6 (Body) • PA66 (Cap)	PTFE	Silicone	M6 x 0.75	—

PMF-12M

STAINLESS STEEL PROTECTIVE VENT

★ ★ NEW

IP68 IP69K



- Stainless steel protective vent for superior durability and chemical resistance.
- IP68 protection class (water depth 2 meters / 60 mins) and -40°C ~ +125°C operating temperature range allows it to be used in various environments.
- Suitable for enclosures with capacities of 20 liters or under.
- For outdoor use, installation on the side of the enclosure unit is recommended.

PMF-12M dimensions

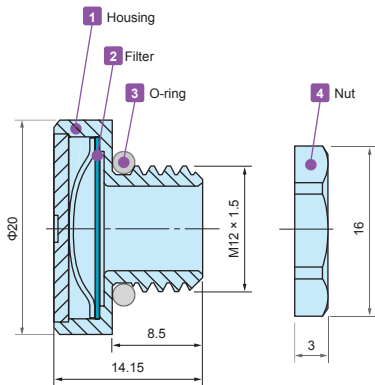

Hole milling drawings

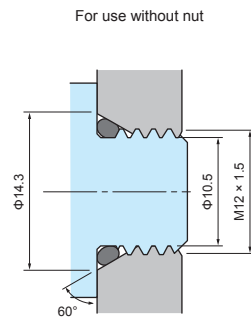

- While φ12.2mm through-hole is sufficient for installation, 60° angle tapered hole is recommended to prevent deformation of the O-ring.

Installation drawings

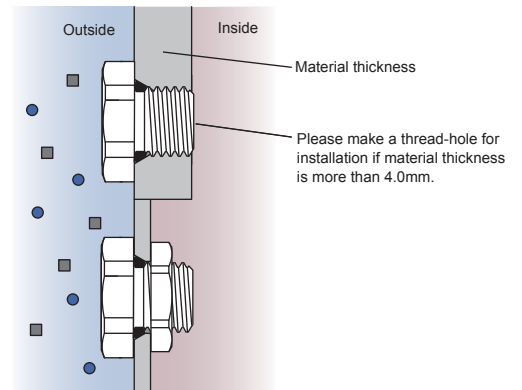

- If used with a lock nut, material thickness should not exceed 4.0mm.

Technical Data

Airflow	1600ml / min (dp = 7 kPa)
Recommended Torque	0.6 ~ 1.2 N · m
Certifications	IEC60529 (Protection class test) : IP66 • IP67 • IP68 • IP69K IEC60068-2-1, 2, 14 (Heat resistance test) : -40°C ~ +125°C IEC60068-2-78 (Humidity test) : 85°C • 85% humidity • 1000 hours IEC60068-2-64 (Vibration test)

Product no. / Dimensions

Product no.	Material				G		Nut SW
	1 Housing	2 Filter	3 O-ring	4 Nut	Thread size	Mount hole	
PMF-12M	Stainless steel	PTFE	Silicone	Brass • Nickel plated	M12 x 1.5	φ12.2	15

PMF SERIES

PROTECTIVE VENT



Application example

- Protective vents prevents the ingress of a variety of contaminants, such as water, dust and other particules while allowing water vapor molecules to diffuse through the microporous membrane.
- Equalize pressure and reduce condensation by allowing airflow into and out of sealed enclosures.
- With an IP68 protection class (water depth 2 meters / 60 mins) and -40°C ~ +125°C operating temperature range, it can be used in harsh environmental conditions.
- PMF-6B works up to 2 liters capacity enclosures. Whereas, PMF-12 models work for up to 5 liters and PMF-12HS models work for up to 50 liters.
- For outdoor use, more efficient to install on the side(s).
- Recommended to use for industrial, electric, electronics purpose only.

PMF dimensions

■ Drawings below are reference examples only.
DXF/DWG/PDF drawings available on our website.

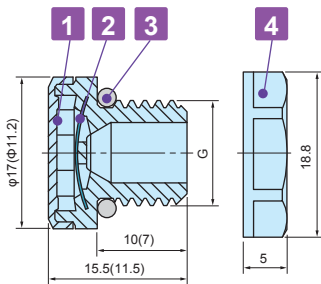

() values are for PMF-6B.
Lock nut is not available for PMF-6B.

Hole milling drawings

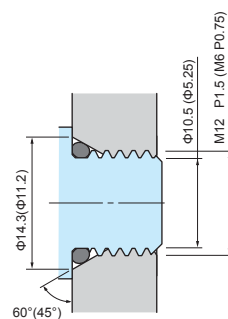

■ While $\Phi 12.2\text{mm}$ through-hole is sufficient for installation, 60° angle tapered hole is recommended to prevent deformation of the O-ring.

Installation drawings

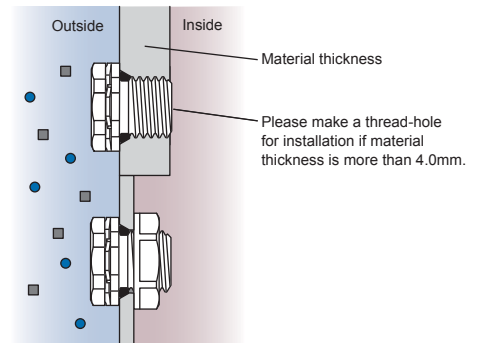

■ If used with a lock nut, material thickness should not exceed 4.0mm, and $\Phi 12.2\text{mm}$ through-hole is sufficient.

Technical Data

Product no.	PMF-6B	PMF-12	PMF-12HA
Airflow	300ml / min (dp = 7 kPa)	450ml / min (dp = 7 kPa)	4000ml / min (dp = 7 kPa)
Recommended Torque	0.2 ~ 0.4 N · m	0.6 ~ 0.8 N · m	0.6 ~ 0.8 N · m
Certifications	IEC60529 (Protection class test): IP66 • IP67 • IP68 • IP69K (Not for PMF-6B) IEC60068-2-1, 2, 14 (Heat resistance test): - 40°C ~ +125°C (~+150°C for PMF-6B) IEC60068-2-78 (Humidity test): 85°C • 85% humidity • 1000 hours IEC60068-2-64 (Vibration test) (PMF-6B only) UL94V-0 (Flame-resistant) • UL746C f1		

Product no. / Dimensions

Product no.		Material				G		Nut SW
● Light gray	● Black	1 Housing	2 Filter	3 O-ring	4 Lock nut	Thread size	Mount hole	
—	NEW PMF-6B	PA6 (Body) PA66 (Cap)	PTFE	Silicone	n/a	M6 x 0.75	—	—
PMF-12S	PMF-12B	PA6	PTFE	Silicone	PA6 (UL94V-2)	M12 x 1.5	$\Phi 12.2$	17
PMF-12HAS	PMF-12HAB	PA6	PTFE	Silicone	PA6 (UL94V-2)	M12 x 1.5	$\Phi 12.2$	17

PMF-32 SERIES

LARGE PROTECTIVE VENT



- Maintaining high airflow for large enclosures in an outdoor environment.
- Equalize pressure and reduce condensation by allowing airflow into and out of sealed enclosures.
- Simple and flat design allows it to be used on a wide variety of enclosure types.
- IP68 protection class rated with an operating temperature range of -40°C ~ +125°C allows it to be used in harsh environments.
- Compliant with Solar industry testing IEC62108 standards.
- For superior performance, installation on the side of the enclosure is recommended.

PMF-32 Dimensions

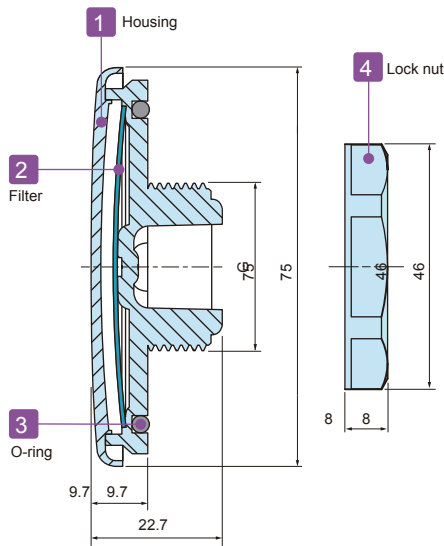

Hole milling drawings

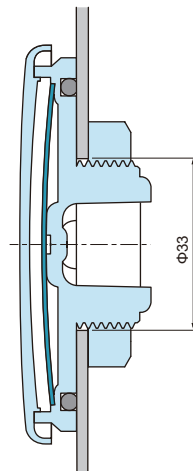

Installation drawings

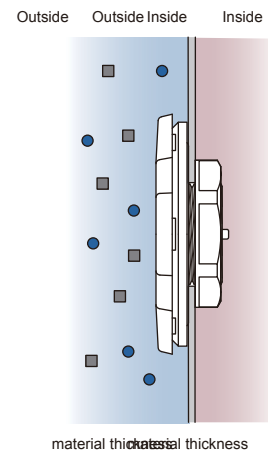

■ If used with a lock nut, material thickness should not exceed 5.0mm.

Technical Data

Airflow	16 ℓ / min (dp = 12 mbar)
Recommended torque	5 N · m
Certifications (without nut)	IEC529, 2nd (Protection class test): IP66 • IP67 • IP68 • IP69K IEC60068-2-1, 2, 14 (Heat resistance test): - 40°C ~ +125°C IEC60068-2-78 (Humidity test): 85°C • 85% humidity • 1000 hours IEC62108.10.8 • 9 (Solar industry test): Freezing - high temperature test • Hail impact test UL94V-0 (Flame-resistant) • UL746C

Product no. / Dimensions

Product no.	Material				G		Nut SW
	1 Housing	2 Filter	3 O-ring	4 Lock nut	Thread size	Mount hole	
PMF-32S	PC	PTFE	Silicone	PA6	M32×1.5	Φ33	41.5

VSC SERIES

ADHESIVE PROTECTIVE VENT FILTER



Technical Data
Water Entry Pressure (WEP): $\geq 20.0\text{kPa}$
Airflow: $450\text{cc}/\text{cm}^2 \cdot \text{min}$ at 1.29Kpa

- Prevents ingress of a variety of contaminants, such as water, dust and other particles.
- Allows water vapor molecules to diffuse through the microporous membrane.
- Recommended to be adhered onto flat plastic or metallic surfaces.

NOTE

- Surface must be wiped dry before adhering.
- An initial period of a few hours is required for the adhesive to properly bond to the surface.
- Please do not adhere onto the top-side of enclosures. Rain water etc will collect on the filter, which will weaken the adhesive seal and prevent ventilation.

Drawing

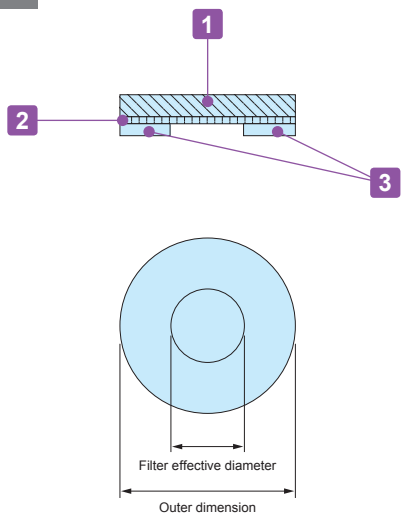

Installation drawing

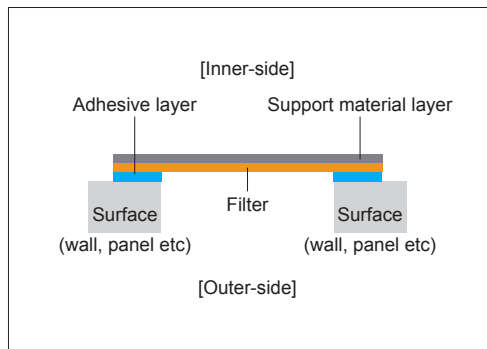

Components

No.	Part name	Material	Color
1	Adhesive	Acrylic adhesive	Transparent
2	Filter	PTFE	White
3	Support material	Polyester fabric	White

Product no. / Dimensions

Product no.	Outer dimension (Φ)	Filter effective diameter (Φ)	Thickness	Sales unit
VSC075	7.5	4.0	0.35	5 pcs (per pack)
VSC130	13.0	8.0	0.35	4 pcs (per pack)
VSC240	24.0	16.0	0.35	4 pcs (per pack)
VSC075-S	7.5	4.0	0.35	100 pcs (per sheet)
VSC130-S	13.0	8.0	0.35	56 pcs (per sheet)
VSC240-S	24.0	16.0	0.35	20 pcs (per sheet)

CNC MACHINING

CNC milling is a form of computer controlled machining. Similar in operation to drilling and cutting, it is able to create various hole styles and shapes by using a rotating cutting tool to bore into the object.



- Mainly used for plastic, aluminium die-cast, and aluminium extrusion material types.
- Able to perform milling for various shapes and sizes.
- Recommended for small quantity customization.

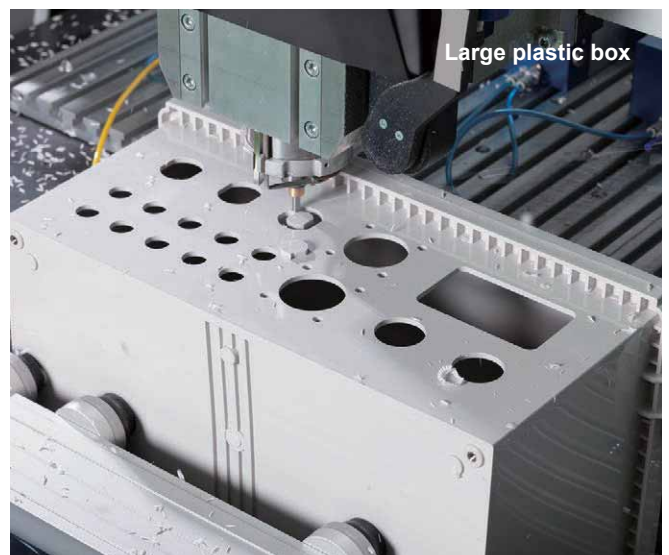

ENGRAVING

By having the drill-head slightly milling the surface, the engraving of fine text or complex designs is able to be performed on a variety of surfaces, be it flat, curved, and so on. Suitable for small batch print, and/or simple lettering. Font shall be similar to VAG Rounded font type.

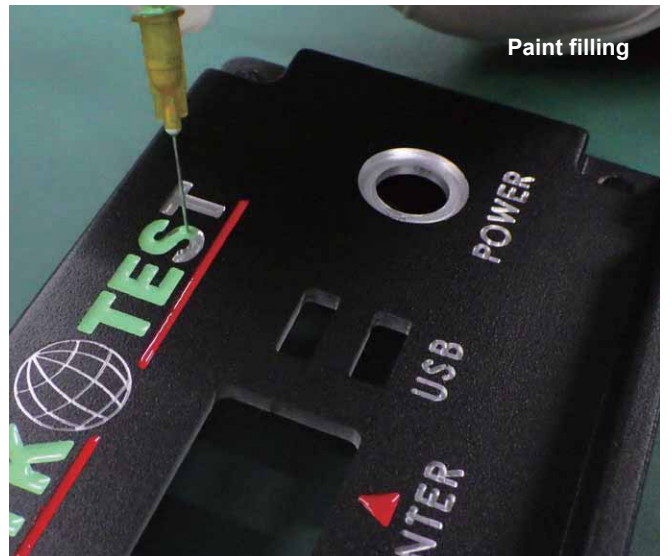
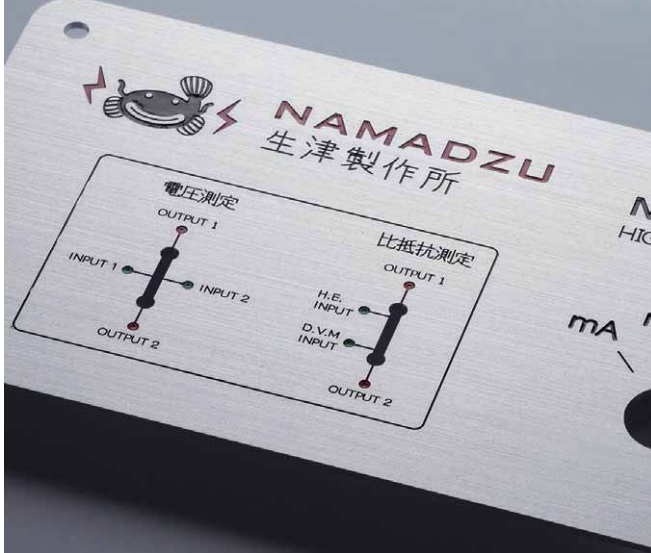

LASER CUTTING

Laser cutting utilizes a laser to perform cutting on an object, allowing various types and shapes of holes to be cut.

New fiber laser machine allows the processing of aluminium sheets with both high precision and speed. Processing of Pure Aluminium 1050 is also possible with minimal burr as compared to conventional CO² laser machines, which causes excessive burring.



PUNCHING PRESS

What is punching press? It is a type of machine press used to cut holes in material via the use of various sized die sets.

Punching press allows the realization of high cost performance due to its high speed automated turret punching process, which significantly reduces machining lead-time.

Due to its ability to create designated sized holes by means of rapid multiple hole punches, this enables it to punch holes of various sizes and types quickly and efficiently.

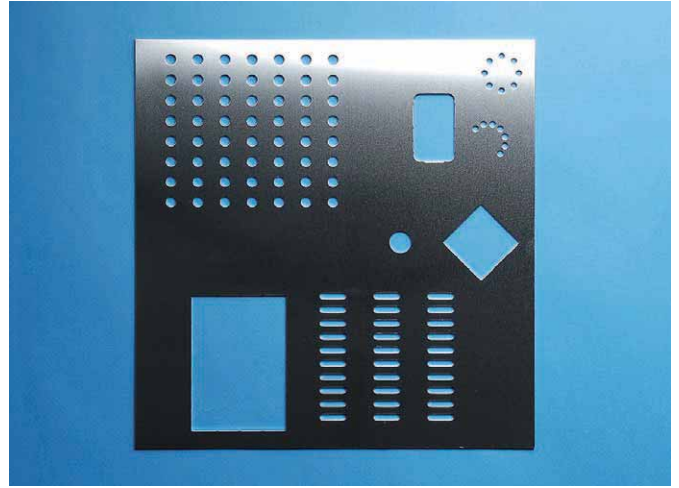
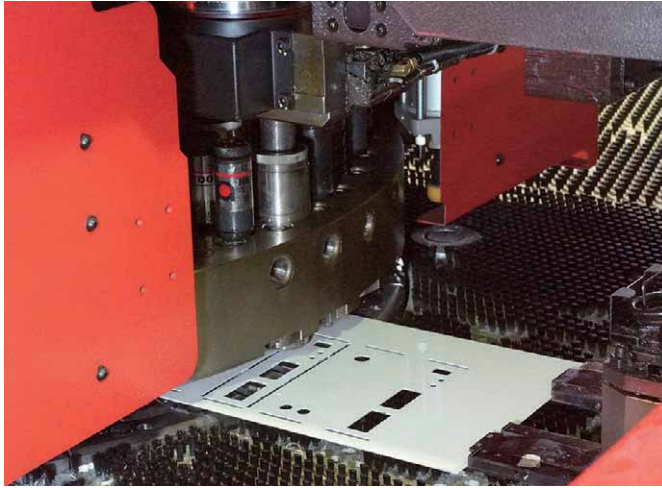

Circular hole

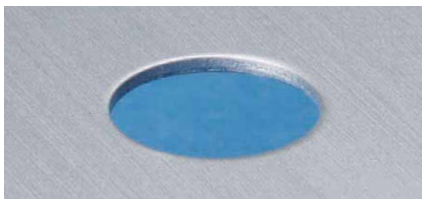

Circular holes as small as 1.0mm in diameter can be punched.

Nibbling press (rectangle)

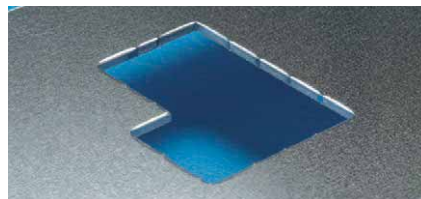

Complex or large rectangular shapes can be punched out with multiple presses.

Nibbling press (round)

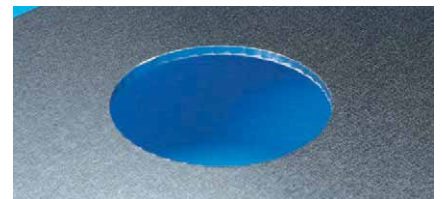

Punching of large circular holes with multiple smaller die strokes.

Common connector shapes

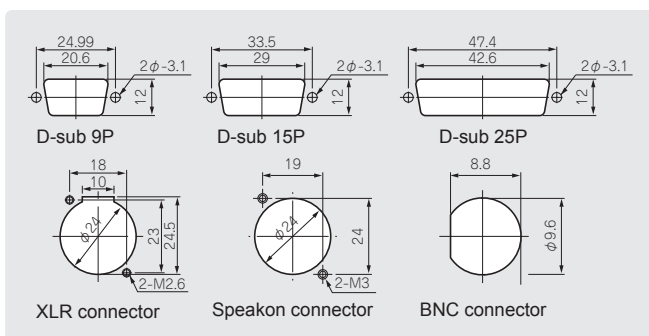

Unique shapes

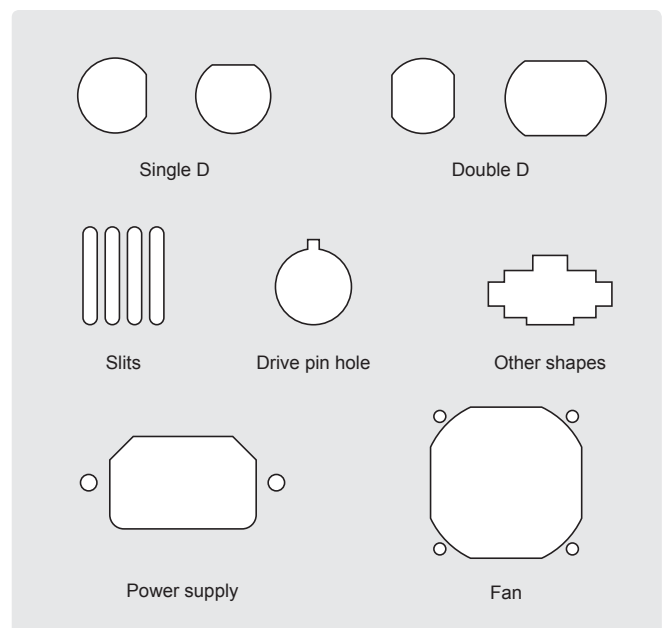

Burring punch



Increasing surface area on a thin metallic sheet for screw threads to bore into.

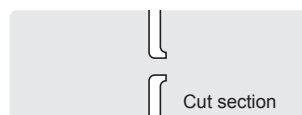

DIGITAL PRINTED OVERLAY



3 reasons for low initial costs

Reason 1

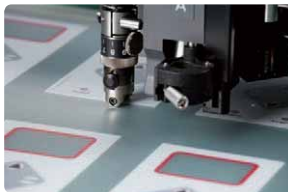

Cutting process



Avoiding the cost for cutting die manufacturing via our in-house cutting plotter.

Reason 2



Printing process



Saving the cost for print plates via utilization of our in-house digital inkjet printer.

Reason 3

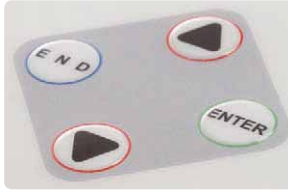

Embossing process



Reducing the cost for the embossing die via our new die manufacturing process.

Comparison of current and previous manufacturing methods

Current

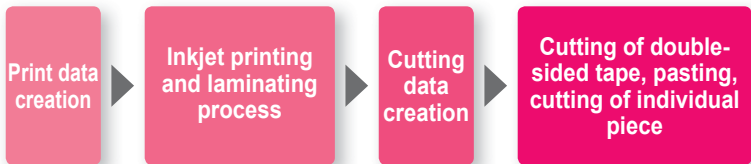

Previous



PRODUCTION PROCESS



1. Inkjet printing on film



2. Laminating



3. Cutting double-sided tape

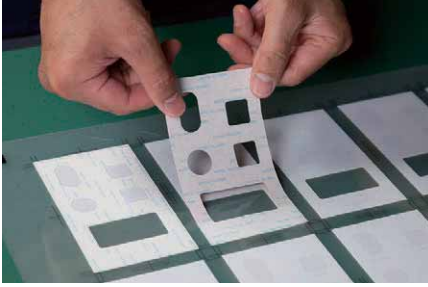

4. Sticking double-sided tape on printed film



5. Cutting the sheet to size



6. Embossing



7. Machining on enclosure



8. Sticking overlay sheet onto enclosure



9. Complete

CUSTOMIZATION EXAMPLE



INKJET PRINTING



Full color digitally designed image can be printed in 1 run.
No cost difference regardless of the number of colors used.

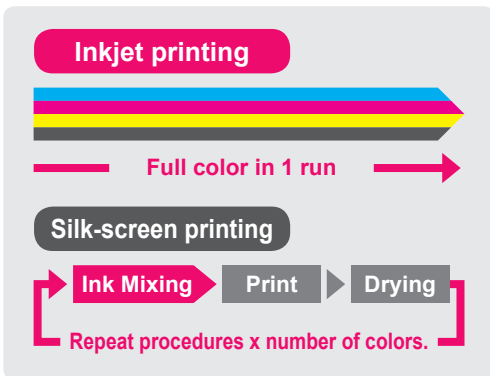

Low printing cost
Full color print possible in small quantities

Inkjet printing 1 run only for full color print

Printing cost Full color

Silk-screen printing Printing cost x number of colors

Printing cost Color 1	Printing cost Color 2	Printing cost Color 3	Printing cost Color 4
-----------------------	-----------------------	-----------------------	-----------------------

High quality printing of photo image and color gradation.

Print photo images in maximum 1,800 x 1,800 dpi quality.

Pictures, logos and unique designs with color gradation can be recreated in a high quality print.



Maximum printable enclosure size



Printable on surfaces with height differential

Printing is possible on recessed, sloped and rounded sections.

Gap difference is less than 2.0mm.

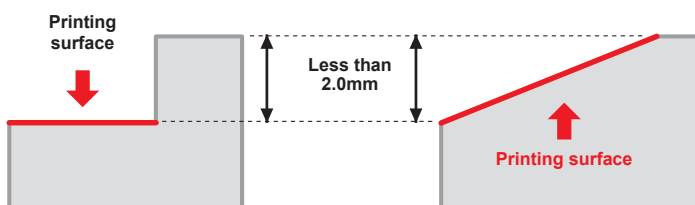

*Not suitable if height difference is more than 2.0mm.



Printed example

