

EXH HEAT-SINK ALUMINIUM ENCLOSURE

EXH series is an aluminium enclosure with a highly efficient heat-sink top cover. Suitable to be used as fanless PC, power amplifier, and power supply box where heat dissipation is required. Wide range, 30 different sizes available.



Waved surface heat-sink fins for maximum cooling performance!

- Each heat-sink fin has a waved surface construction for maximum cooling performance.

Waved Surface



HEAT DISSIPATION EXAMPLE

- EXH series has grooves to put M3 nuts inside its heat-sink cover. It is possible to construct a heat conduction route from your heat source to heat-sink cover easily for better heat dissipation performance.

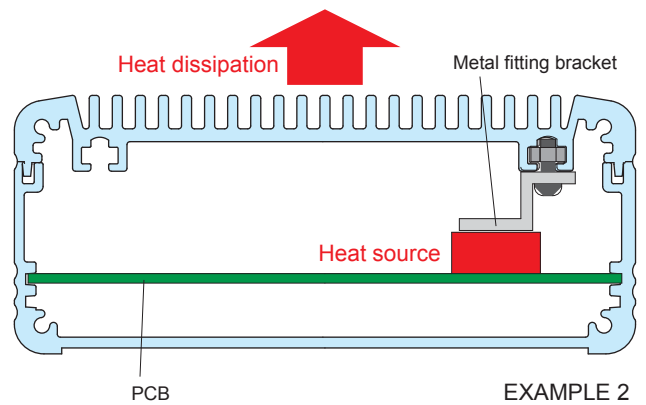
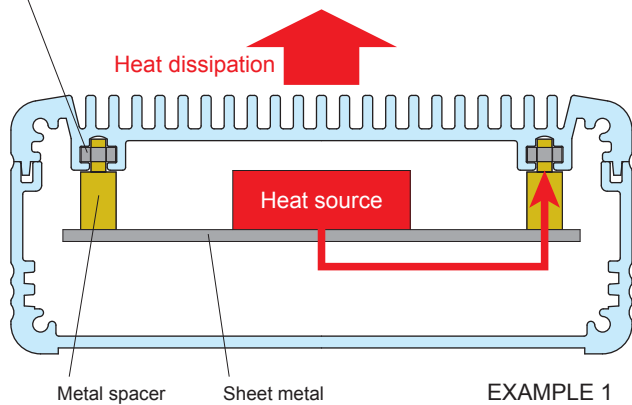

CUSTOMIZATION EXAMPLE

CNC MACHINING on HEAT-SINK COVER



Heat-sink plates can be customized with our high speed CNC machines.



PIN SHAPED FIN CUSTOMIZATION



Pin shaped heat-sink fin can be customized for better cooling performance.

COLOR ANODIZING

Various colors, such as blue, red, orange, green or purple can be anodized as per your requirements.



■ Not all colors and shades of colors are possible.

CUSTOM LENGTH AVAILABLE



APPLICATION EXAMPLE

STABILIZED DIODE LASER Product by Spectra Quest Lab. (Japan)

Controller



Laser Head



IOT GATEWAY

Product by VNPT Technology (Vietnam)



ULTRASONIC NOZZLE CLEANER

Product by ESER Corporation (Japan)



TAKACHI PF plastic enclosure is also adopted.

ALL-IN-ONE EDGE NODE

Product by SHINWA (Japan)



4 CHANNEL POWER SWITCHING EDGE NODE

Product by SHINWA (Japan)



AUDIO AMPLIFIER



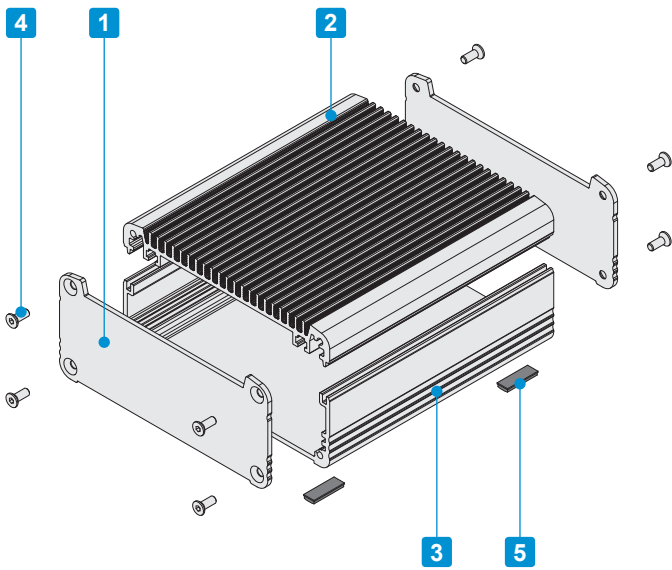

- Aluminum enclosure equipped with a highly efficient heat-sink top cover.
- Suitable to be used as a fanless PC, power amplifier, power supply etc. where heat dissipation is required.
- Selectable in 58 different sizes and 4 different color combinations.
- Grooves for M3 sliding nut are built into the heat-sink top cover and bottom frame (140mm or wider).

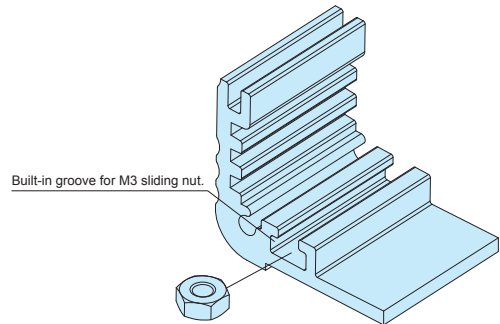

Components

No.	Part name	Pcs	Material	Color / Finish
1	Panel	2	Aluminium A1050P	Silver • Black / Anodized
2	Heat-sink top cover	1	Extruded aluminium A6063S-T5	Silver • Black / Anodized
3	Bottom frame	1	Extruded aluminium A6063S-T5	Silver • Black / Anodized
4	Screw (Hexagonal)	8	Stainless steel	Unfinished
5	Rubber feet	4	Polyurethane	Black

Color Type

Code	S S Silver / Silver	S B Silver / Black	B S Black / Silver	B B Black / Black
Color				

DXF/DWG/PDF drawings available on our website.

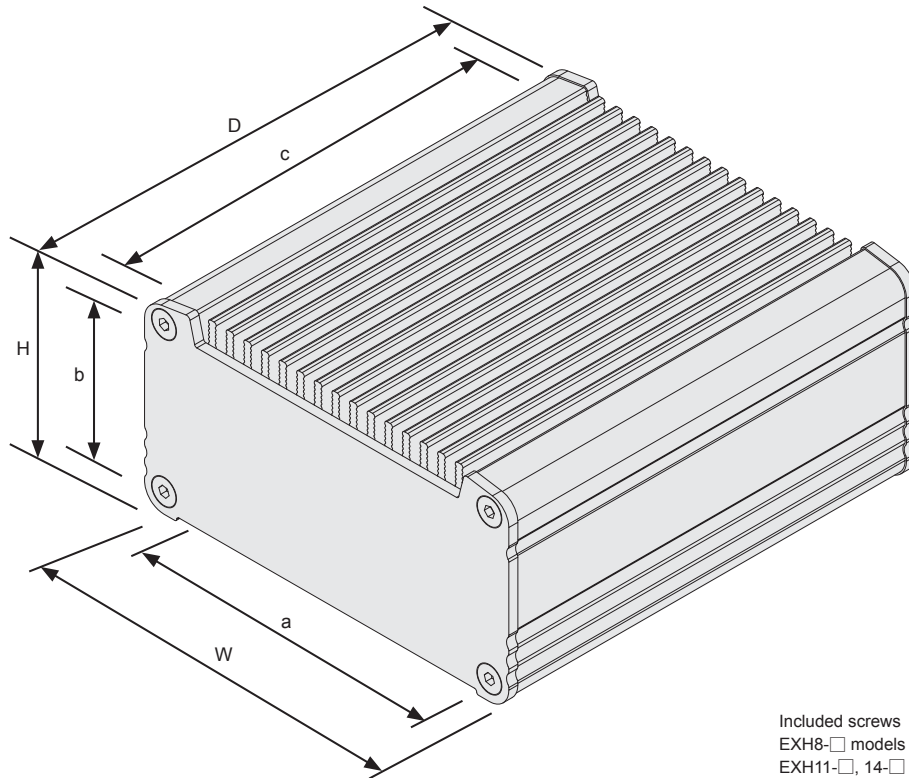

Included screws
 EXH8-□ models : M2.5-8 x 8 pcs
 EXH11-□, 14-□ models : M3-8 x 8 pcs
 EXH19-□ models : M4-10 x 8 pcs
 EXH23-□ models : M5-10 x 8 pcs
 ※Hexagonal wrench included.

Product no. / Dimensions

Please suffix color code at the end of the product number.

Product no.	External dimensions			Internal dimensions			※Thermal resistance rate (°C/W)
	W	H	D	a	b	c	
EXH 8-3- 6□□	80.6	30.7	60	69.6	20.3	56	7.32
EXH 8-3- 9□□	80.6	30.7	90	69.6	20.3	86	5.65
EXH 8-3-12□□	80.6	30.7	120	69.6	20.3	116	4.72
EXH 8-4- 6□□	80.6	40.7	60	69.6	30.3	56	7.32
EXH 8-4- 9□□	80.6	40.7	90	69.6	30.3	86	5.65
EXH 8-4-12□□	80.6	40.7	120	69.6	30.3	116	4.72
EXH 8-6- 6□□	80.6	55.7	60	69.6	45.3	56	7.32
EXH 8-6- 9□□	80.6	55.7	90	69.6	45.3	86	5.65
EXH 8-6-12□□	80.6	55.7	120	69.6	45.3	116	4.72
EXH11-3- 8□□	106	31.1	78	94.6	19.3	74	4.82
EXH11-3-12□□	106	31.1	118	94.6	19.3	114	3.72
EXH11-3-16□□	106	31.1	164	94.6	19.3	160	3.03
EXH11-5- 8□□	106	46.1	78	94.6	34.3	74	4.82
EXH11-5-12□□	106	46.1	118	94.6	34.3	114	3.72
EXH11-5-16□□	106	46.1	164	94.6	34.3	160	3.03
EXH11-6- 8□□	106	61.1	78	94.6	49.3	74	4.82
EXH11-6-12□□	106	61.1	118	94.6	49.3	114	3.72
EXH11-6-16□□	106	61.1	164	94.6	49.3	160	3.03
EXH14-4-10□□	141	36.1	97	129.6	24.3	93	3.4
EXH14-4-14□□	141	36.1	137	129.6	24.3	133	2.75
EXH14-4-19□□	141	36.1	187	129.6	24.3	183	2.27
EXH14-5-10□□	141	51.1	97	129.6	39.3	93	3.4
EXH14-5-14□□	141	51.1	137	129.6	39.3	133	2.75
EXH14-5-19□□	141	51.1	187	129.6	39.3	183	2.27
EXH14-7-10□□	141	71.1	97	129.6	59.3	93	3.4
EXH14-7-14□□	141	71.1	137	129.6	59.3	133	2.75
EXH14-7-19□□	141	71.1	187	129.6	59.3	183	2.27
EXH14-9-10□□	141	91.1	97	129.6	79.3	93	3.4
EXH14-9-14□□	141	91.1	137	129.6	79.3	133	2.75
EXH14-9-19□□	141	91.1	187	129.6	79.3	183	2.27

Custom length available.

Product no.	External dimensions			Internal dimensions			※Thermal resistance rate (°C/W)
	W	H	D	a	b	c	
NEW EXH19- 4-13□□	186.5	43.5	125	170	26.85	120	1.92
NEW EXH19- 4-18□□	186.5	43.5	177	170	26.85	172	1.56
NEW EXH19- 4-23□□	186.5	43.5	230	170	26.85	225	1.32
NEW EXH19- 4-29□□	186.5	43.5	285	170	26.85	280	1.15
NEW EXH19- 6-13□□	186.5	61.5	125	170	44.85	120	1.92
NEW EXH19- 6-18□□	186.5	61.5	177	170	44.85	172	1.56
NEW EXH19- 6-23□□	186.5	61.5	230	170	44.85	225	1.32
NEW EXH19- 6-29□□	186.5	61.5	285	170	44.85	280	1.15
NEW EXH19- 8-13□□	186.5	81.5	125	170	64.85	120	1.92
NEW EXH19- 8-18□□	186.5	81.5	177	170	64.85	172	1.56
NEW EXH19- 8-23□□	186.5	81.5	230	170	64.85	225	1.32
NEW EXH19- 8-29□□	186.5	81.5	285	170	64.85	280	1.15
NEW EXH19-11-13□□	186.5	106.5	125	170	89.85	120	1.92
NEW EXH19-11-18□□	186.5	106.5	177	170	89.85	172	1.56
NEW EXH19-11-23□□	186.5	106.5	230	170	89.85	225	1.32
NEW EXH19-11-29□□	186.5	106.5	285	170	89.85	280	1.15
NEW EXH23- 5-15□□	232	52	153	215	34.85	147	1.47
NEW EXH23- 5-21□□	232	52	213	215	34.85	207	1.2
NEW EXH23- 5-27□□	232	52	273	215	34.85	267	1.03
NEW EXH23- 5-33□□	232	52	333	215	34.85	327	0.91
NEW EXH23- 8-15□□	232	77	153	215	59.85	147	1.47
NEW EXH23- 8-21□□	232	77	213	215	59.85	207	1.2
NEW EXH23- 8-27□□	232	77	273	215	59.85	267	1.03
NEW EXH23- 8-33□□	232	77	333	215	59.85	327	0.91
NEW EXH23-10-15□□	232	102	153	215	84.85	147	1.47
NEW EXH23-10-21□□	232	102	213	215	84.85	207	1.2
NEW EXH23-10-27□□	232	102	273	215	84.85	267	1.03
NEW EXH23-10-33□□	232	102	333	215	84.85	327	0.91

※Thermal resistance test condition
 • Ambient air cooling
 • Heat-sink fins are set perpendicular to the ground with temperature at 60°C.
 • Anodized aluminum extrusion
 • Heat source is applied on the opposite side (inner side) of the fins.

EXHF SERIES

FLANGED HEAT-SINK ALUMINIUM ENCLOSURE

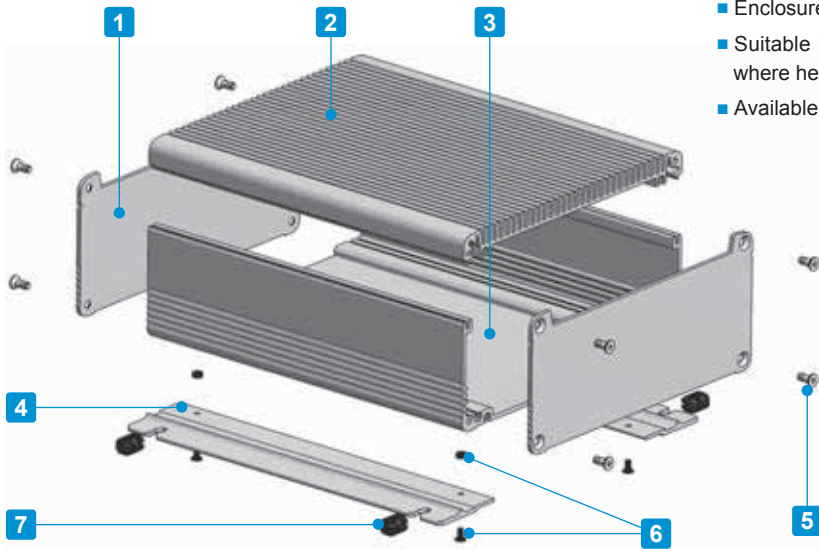

- Equipped with flanged bracket for easy wall mounting.
- Enclosure equipped with a highly efficient heat-sink top cover.
- Suitable to be used as a fanless PC, amplifier, power supply etc. where heat dissipation is required.
- Available in 28 different sizes and 4 different color combinations.

Components

No.	Part name	Pcs	Material	Color / Finish
1	Panel	2	Aluminium A1050P	Silver • Black / Anodized
2	Heat-sink top cover	1	Extruded aluminium A6063S-T5	Silver • Black / Anodized
3	Bottom frame	1	Extruded aluminium A6063S-T5	Silver • Black / Anodized
4	Flange bracket	2	Extruded aluminium A6063S-T5	Silver • Black / Anodized
5	Panel screw (Hexagonal)	8	Stainless steel	Unfinished
6	Flange screw	4	Steel	Trivalent chromate
7	Rubber feet	4	Silicone	Black

Color Type

Code	S S Silver / Silver	S B Silver / Black	B S Black / Silver	B B Black / Black
Color				

DXF/DWG/PDF drawings available on our website.

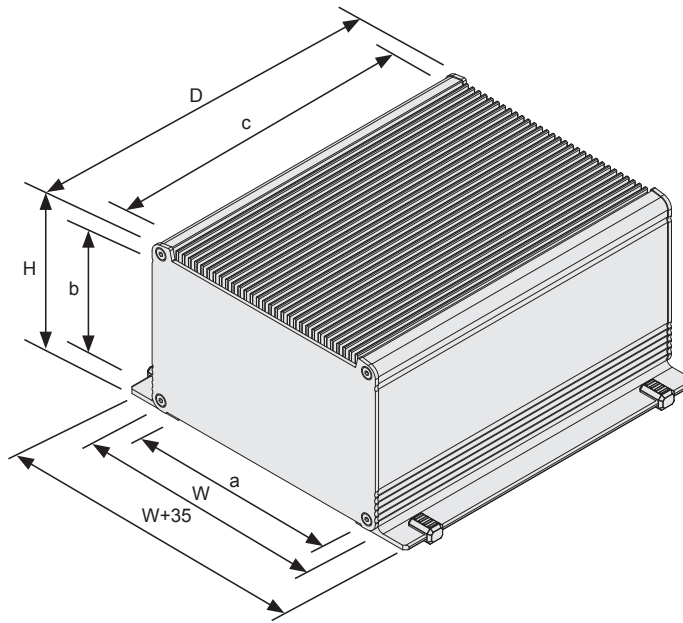

Included screws
 EXHF19-□ models : M4-10 x 8 pcs
 EXHF23-□ models : M5-10 x 8 pcs
 ※Hexagonal wrench included.

- ※Thermal resistance test condition
- Ambient air cooling
 - Heat-sink fins are set perpendicular to the ground with temperature at 60°C.
 - Anodized aluminum extrusion
 - Heat source is applied on the opposite side (inner side) of the fins.

Product no. / Dimensions

Please suffix color code at the end of the product number.

Product no.	External dimensions			Internal dimensions			※Thermal resistance rate (°C/W)
	W	H	D	a	b	c	
NEW EXHF19- 4-13□□	186.5	45.25	125	170	26.85	120	1.92
NEW EXHF19- 4-18□□	186.5	45.25	177	170	26.85	172	1.56
NEW EXHF19- 4-23□□	186.5	45.25	230	170	26.85	225	1.32
NEW EXHF19- 4-29□□	186.5	45.25	285	170	26.85	280	1.15
NEW EXHF19- 6-13□□	186.5	63.25	125	170	44.85	120	1.92
NEW EXHF19- 6-18□□	186.5	63.25	177	170	44.85	172	1.56
NEW EXHF19- 6-23□□	186.5	63.25	230	170	44.85	225	1.32
NEW EXHF19- 6-29□□	186.5	63.25	285	170	44.85	280	1.15
NEW EXHF19- 8-13□□	186.5	83.25	125	170	64.85	120	1.92
NEW EXHF19- 8-18□□	186.5	83.25	177	170	64.85	172	1.56
NEW EXHF19- 8-23□□	186.5	83.25	230	170	64.85	225	1.32
NEW EXHF19- 8-29□□	186.5	83.25	285	170	64.85	280	1.15
NEW EXHF19-11-13□□	186.5	108.25	125	170	89.85	120	1.92
NEW EXHF19-11-18□□	186.5	108.25	177	170	89.85	172	1.56
NEW EXHF19-11-23□□	186.5	108.25	230	170	89.85	225	1.32
NEW EXHF19-11-29□□	186.5	108.25	285	170	89.85	280	1.15
NEW EXHF23- 5-15□□	232	53.5	153	215	34.85	147	1.47
NEW EXHF23- 5-21□□	232	53.5	213	215	34.85	207	1.2
NEW EXHF23- 5-27□□	232	53.5	273	215	34.85	267	1.03
NEW EXHF23- 5-33□□	232	53.5	333	215	34.85	327	0.91
NEW EXHF23- 8-15□□	232	78.5	153	215	59.85	147	1.47
NEW EXHF23- 8-21□□	232	78.5	213	215	59.85	207	1.2
NEW EXHF23- 8-27□□	232	78.5	273	215	59.85	267	1.03
NEW EXHF23- 8-33□□	232	78.5	333	215	59.85	327	0.91
NEW EXHF23-10-15□□	232	103.5	153	215	84.85	147	1.47
NEW EXHF23-10-21□□	232	103.5	213	215	84.85	207	1.2
NEW EXHF23-10-27□□	232	103.5	273	215	84.85	267	1.03
NEW EXHF23-10-33□□	232	103.5	333	215	84.85	327	0.91

Grooves for M3 sliding nut are found on the heat-sink top cover and bottom frame (140mm or wider).

Flange bracket is installed as per the diagram below.

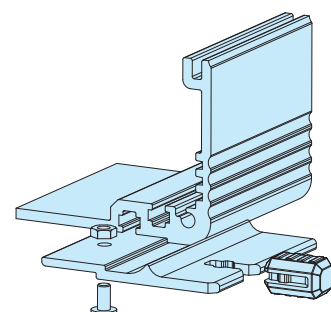
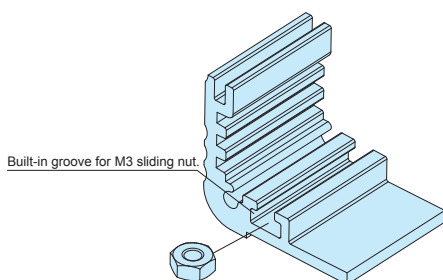

EXH • EXHF heat-sink top cover / bottom frame

■ Drawings below are reference examples only.
DXF/DWG/PDF drawings available on our website.

EXH8-3-□

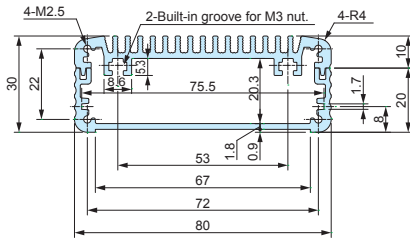

EXH8-4-□

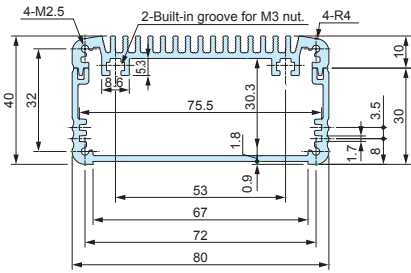

EXH8-6-□

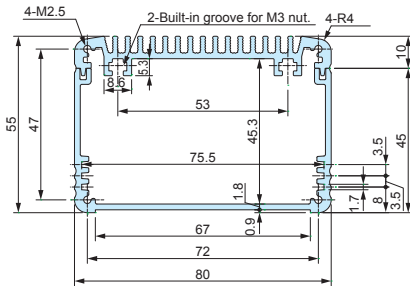

EXH11-3-□

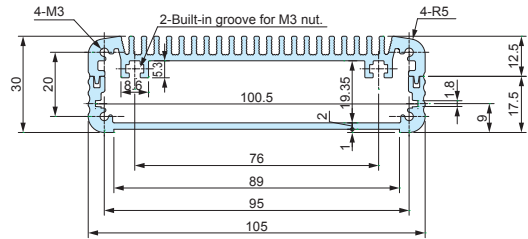

EXH11-5-□

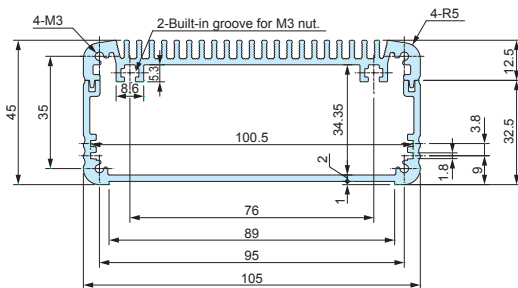

EXH11-6-□

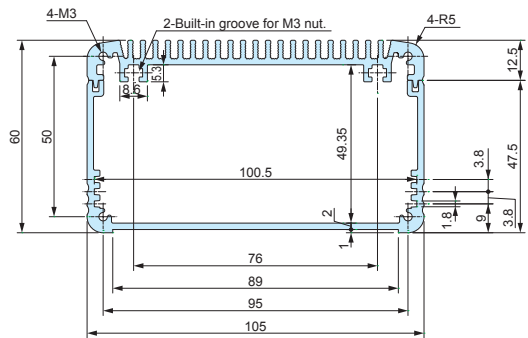

EXH14-4-□

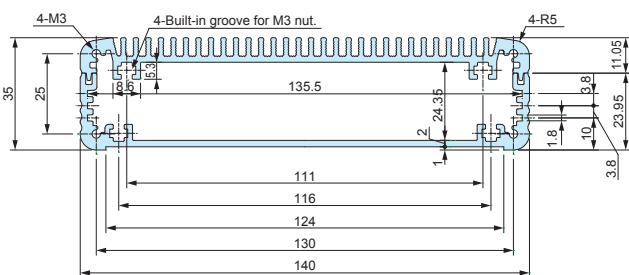

EXH14-5-□

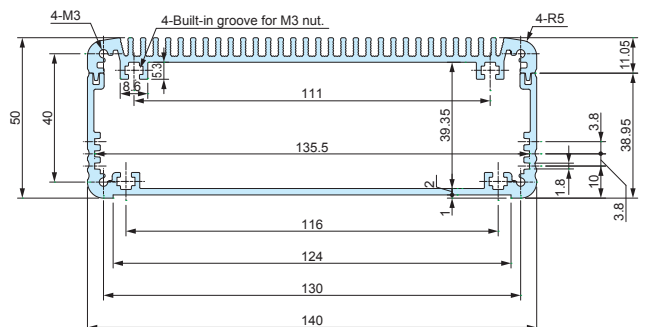

EXH14-7-□

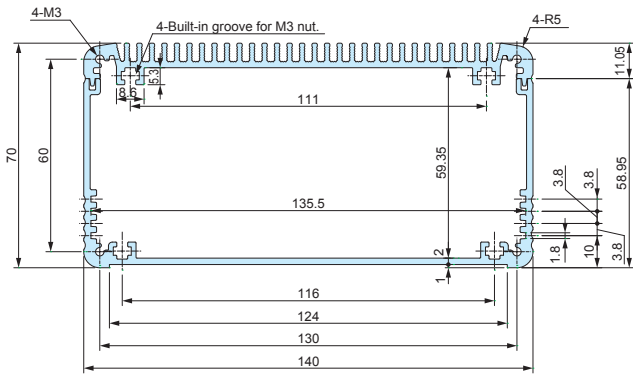

EXH14-9-□

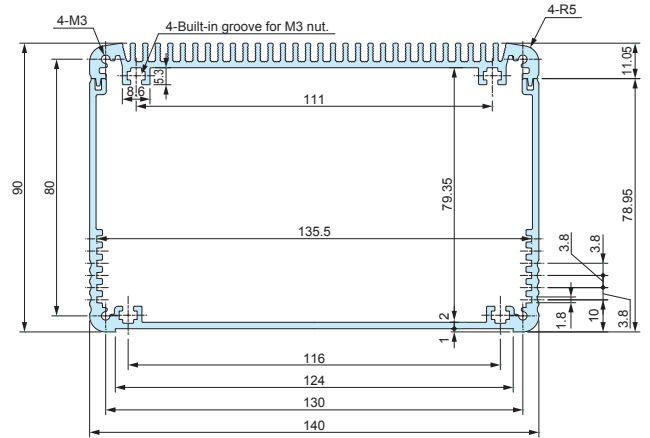

EXH • EXHF19-4-□

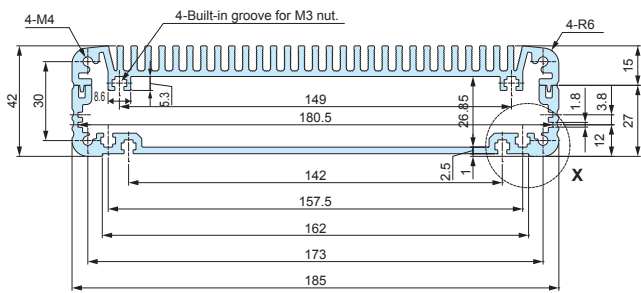

EXH • EXHF19-6-□

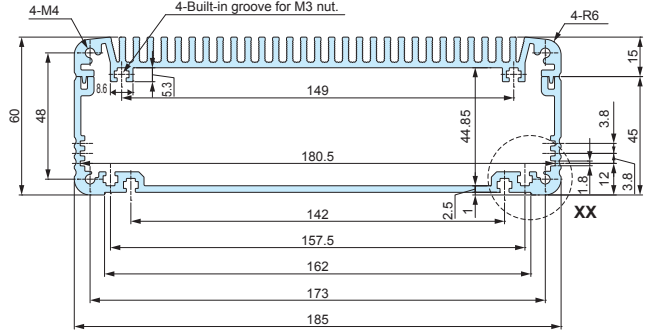

Flange bracket dimensions for EXHF series.

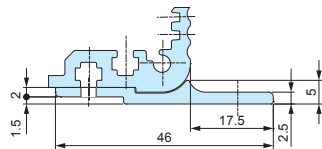

detail X (enlarged)

Flange bracket dimensions for EXHF series.

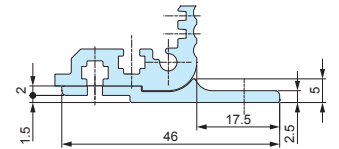

detail XX (enlarged)

EXH • EXHF19-8-□

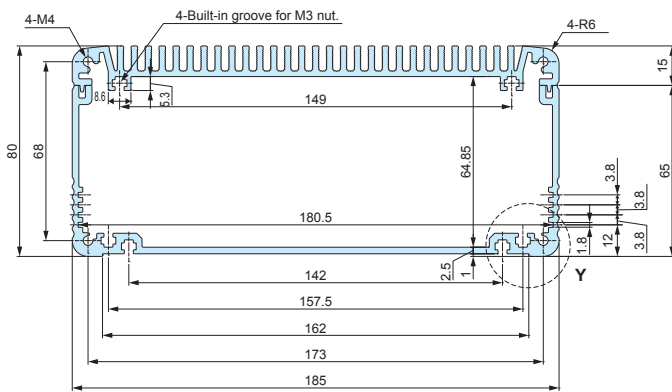

EXH • EXHF19-11-□

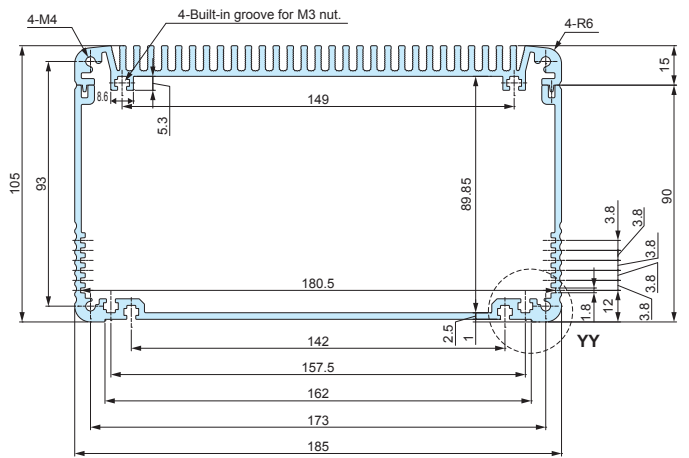

Flange bracket dimensions for EXHF series.

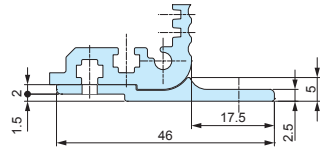

detail Y (enlarged)

Flange bracket dimensions for EXHF series.

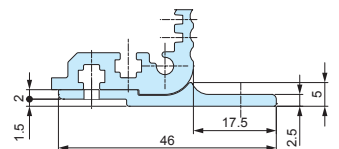

detail YY (enlarged)

EXH • EXHF heat-sink top cover / bottom frame

■ Drawings below are reference examples only.
DXF/DWG/PDF drawings available on our website.

EXH • EXHF23-5-□

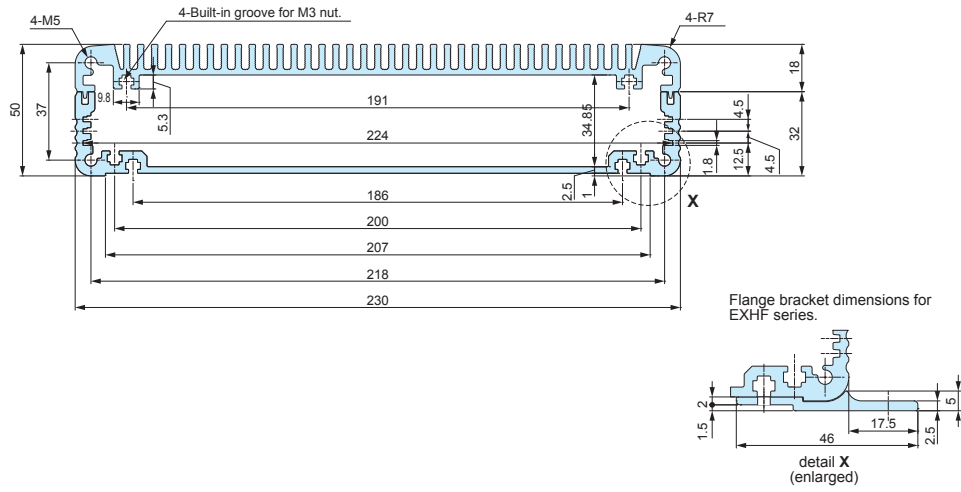

EXH • EXHF23-8-□

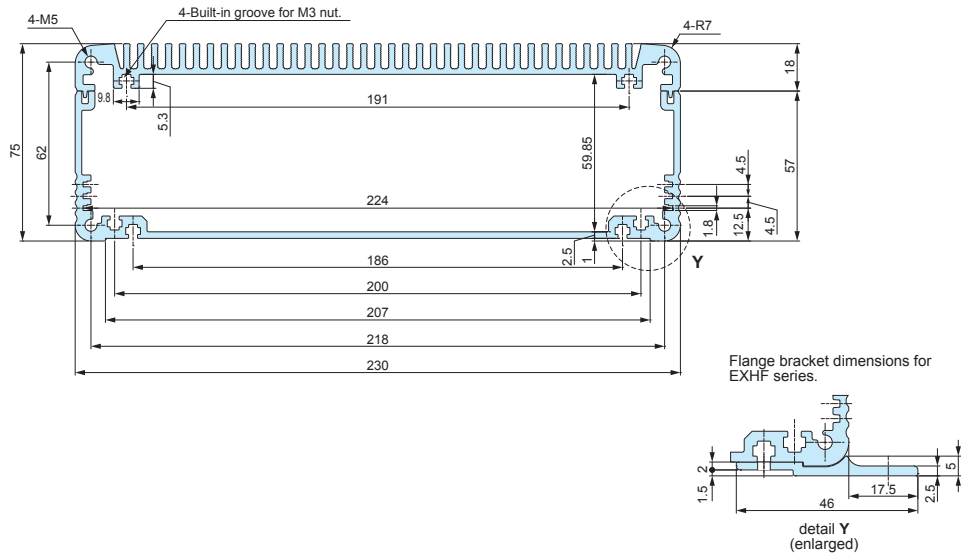

EXH • EXHF23-10-□

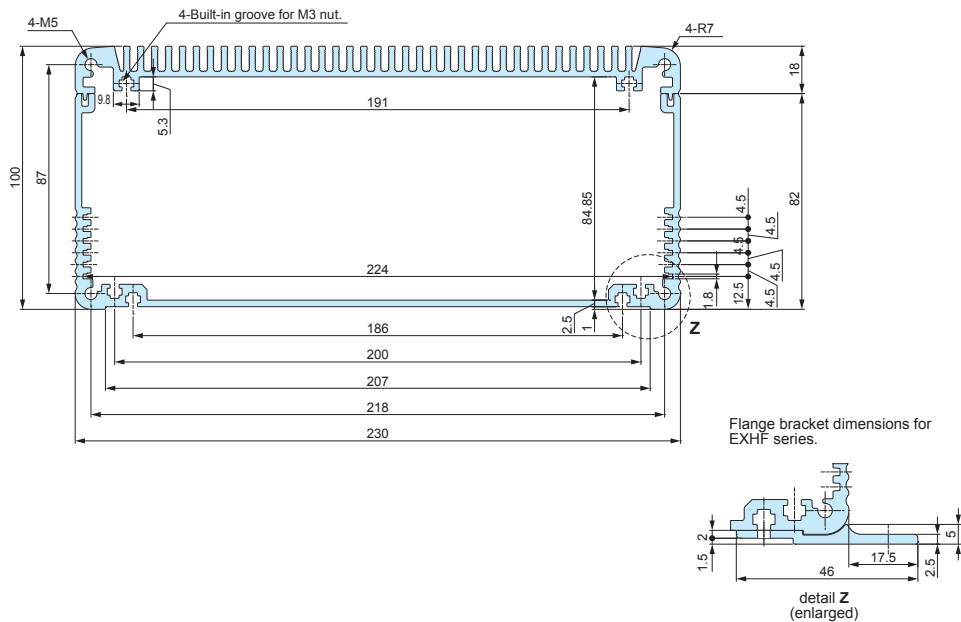

EF SERIES

WALL MOUNTING BRACKET for EX • EXH



APPLICATION EXAMPLE



- Wall mounting bracket for EX • EXH series. Applicable only for width 185 and 225mm bottom covers.
- Easy installation by inserting the nuts into built-in grooves on EX • EXH bottom cover.
- Rubber feet are included to mask the mounting cutouts when not used for wall mounting.

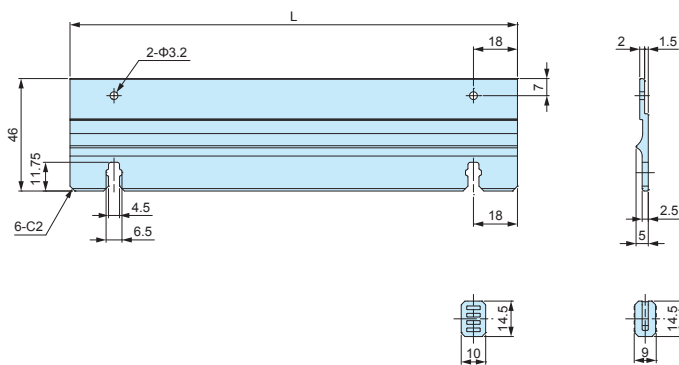

Assembly drawings

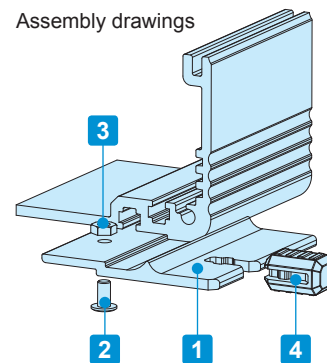

Components

No.	Part name	Pcs	Material	Color / Finish
1	Bracket	2	Extruded aluminium A6063S-T5	Silver • Black / Anodized
2	Screw	4	Steel M3-6	Black trivalent chromate
3	Nut	4	Steel	Black trivalent chromate
4	Rubber feet	4	Silicone	Black

Product no. / Dimensions

Product no.		L	Suitable enclosure
● Silver	● Black		
NEW EF19-13S	NEW EF19-13B	119.5	EX • EXH19-○-13□□
NEW EF19-18S	NEW EF19-18B	171.5	EX • EXH19-○-18□□
NEW EF19-23S	NEW EF19-23B	224.5	EX • EXH19-○-23□□
NEW EF19-29S	NEW EF19-29B	279.5	EX • EXH19-○-29□□
NEW EF23-15S	NEW EF23-15B	146.5	EX • EXH23-○-15□□
NEW EF23-21S	NEW EF23-21B	206.5	EX • EXH23-○-21□□
NEW EF23-27S	NEW EF23-27B	266.5	EX • EXH23-○-27□□
NEW EF23-33S	NEW EF23-33B	326.5	EX • EXH23-○-33□□

MT-3N

SLIDING NUT for EXH • EXHF

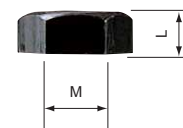
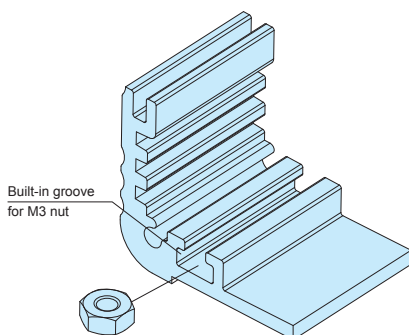

Product no. / Dimensions

Product no.	M	L	Material	Finish	Pack of
MT-3N	3	2.4	Steel	Black trivalent chromate	50

- Sliding nut can be used on all EXH • EXHF heat-sink top covers, as well as with width 140mm or larger bottom covers.



Application Example

- Double shot injection molded feet with soft and well-designed rounded shape.
- Non-slip design with Elastomer (TPE) pad.
- Available in 3 different color patterns.

Technical Data
Max load : 7kg

Components

No.	Part name	Pcs	Material	Color / Finish
1	Front feet	2	PC+ABS UL94V-0, TPE	Black & Black • Navy & Gray • Light gray & Gray
2	Rear Feet	2	PC+ABS UL94V-0, TPE	Black & Black • Navy & Gray • Light gray & Gray
-	Washer head screw	4	Steel M3-6	Black Trivalent chromate
-	Nut	4	Steel M3	Black Trivalent chromate

- Drawings below are reference examples only.
DXF/DWG/PDF drawings available on our website.

Mounting hole (Front)

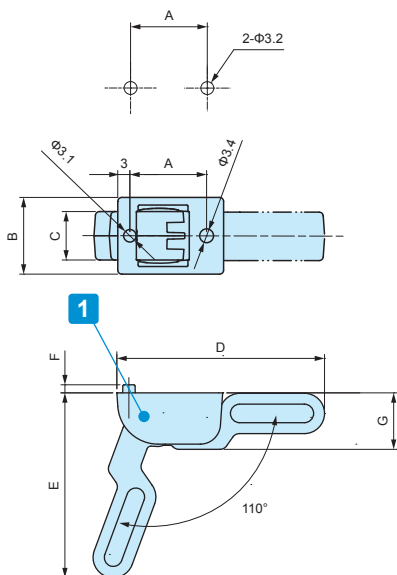

Mounting Hole (Rear)

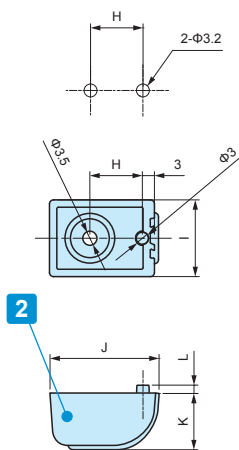

- Possible to install on Built-in groove with M3 nut for all EXP • EXPE • EXW • EX • EXH models with width 185mm or larger bottom covers.
- TLW-70E models are exclusively for width 185mm or larger bottom covers.

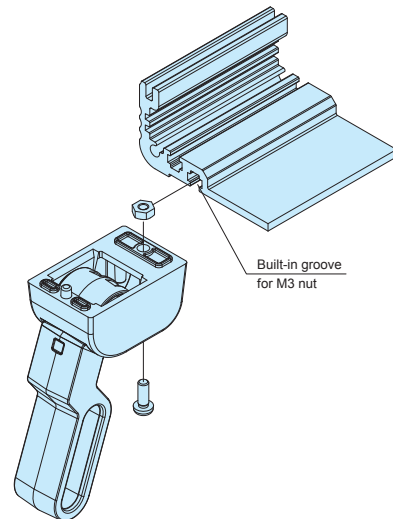

Product no. / Dimensions

Product no.	A	B	C	D	E	F	G	H	I	J	K	L	Color (plastic)	Color (TPE)	Weight (g)
TLW-46BB	19	19	12	51.2	45.9	2	14	13	19	27	14	2	Black	Black	23
TLW-46NG	19	19	12	51.2	45.9	2	14	13	19	27	14	2	Navy	Gray	23
TLW-46LG	19	19	12	51.2	45.9	2	14	13	19	27	14	2	Light gray	Gray	23
NEW TLW-70EBB	30	25	16	75.4	69	3	21.5	20	25	39	21.5	3	Black	Black	59
NEW TLW-70ENG	30	25	16	75.4	69	3	21.5	20	25	39	21.5	3	Navy	Gray	59
NEW TLW-70ELG	30	25	16	75.4	69	3	21.5	20	25	39	21.5	3	Light gray	Gray	59

AWA SERIES HEAT-SINK ALUMINIUM ENCLOSURE

AWA series is an aluminium enclosure that has a frame with heat-sink fins on both sides. Furthermore, the enclosure is also conductive, which provides a shielding effect.

By machining the panels, the unit becomes extremely suitable to be used as high-end audio, or as an industrial equipment.

APPLICATION EXAMPLE

INDUSTRIAL IoT INTERFACE DEVICE

Product by SEE Système Radio (France)



INDUSTRIAL FANLESS PC



AUDIO AMPLIFIER



WIDE-BAND SOLID STATE OPTICAL AMPLIFIER

Product by Spectra Quest Lab. (Japan)

CUSTOMIZATION

CNC milling available for customization on AWA series.
See website for more details.



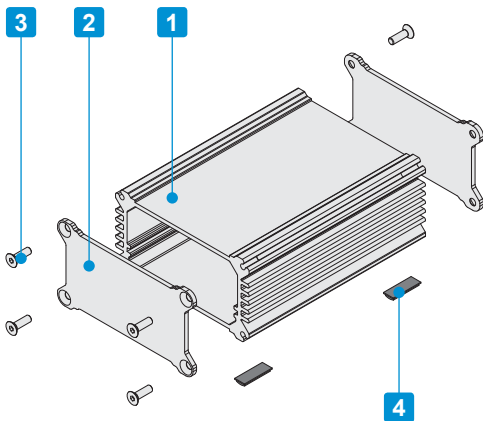
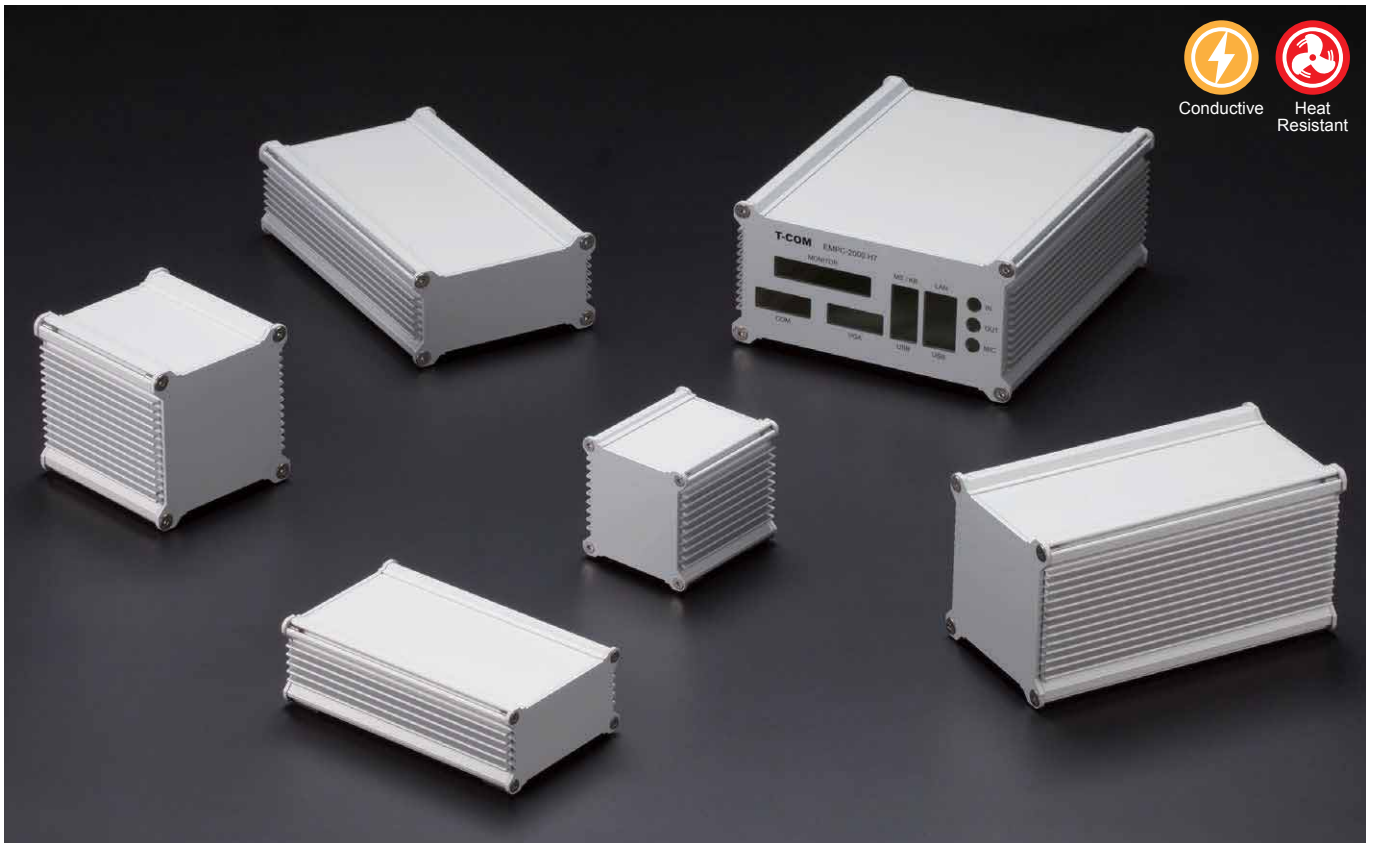

- Extruded aluminium frame manufactured with heat-sink sides.
- Silver anodized end panels makes for a luxurious finish.
- Conductivity is achieved by utilizing the contact between the unfinished end panels side, and the unfinished ends of the frame.
- PCB or chassis can be horizontally mounted by sliding into an inner-grooved body frame.
- Suitable for industrial fanless PC, measuring instrument, digital audio amplifier and so on.

Included screws :
 AWA5-3, 6-6, 8-4 models : Hex countersunk M3-10 x 8 pcs
 AWA8-8, 10-5, 12-7, 15-8 models : Hex countersunk M4-10 x 8 pcs
 AWA20-8 models : Hex countersunk M5-10 x 8 pcs
 ※Hexagonal wrench included.

Component

No.	Part name	Pcs	Material	Color / Finish
1	Body frame	1	Extruded aluminium A6063S-T5	Silver / Anodized
2	End panel	2	Aluminium A1050P	Silver / Anodized (outside) : Unfinished (inside)
3	Hex socket screw	8	Stainless steel	Unfinished
4	Rubber feet	4	Polyurethane	Black

Accessories (Optional parts)



Mounting plate AWC series
See page 170



Aluminium isolation feet AFS • AFM series
See page AFS • AFM-1 ~ AFS • AFM-2

■ Drawings below are reference examples only.
DXF/DWG/PDF drawings available on our website.

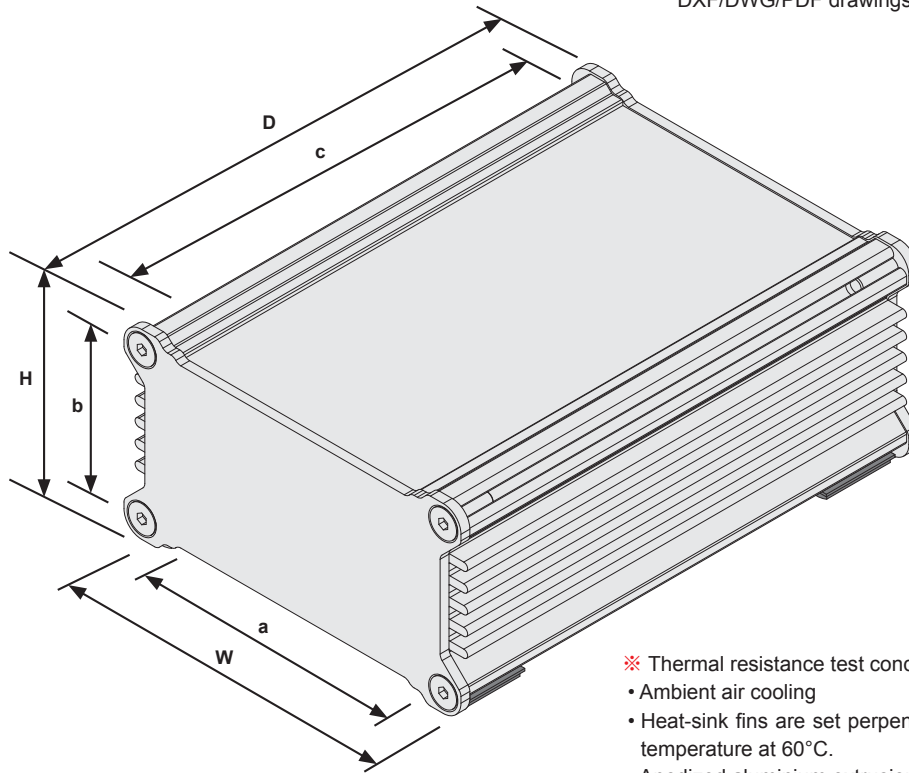

- ※ Thermal resistance test condition
- Ambient air cooling
 - Heat-sink fins are set perpendicular to the ground with temperature at 60°C.
 - Anodized aluminium extrusion
 - Heat source is applied on the opposite side (inner side) of the fins.

Product no. / Dimensions

Product no.	Dimensions (External)			Dimensions (Internal)			※ Thermal resistance rate (°C/W)	Weight (g)
	W	H	D	a	b	c		
AWA 5-3- 5SS	52	32	53.2	39	22.5	49.2	11.2	69.5
AWA 5-3- 7SS	52	32	73.2	39	22.5	69.2	9.18	90.5
AWA 5-3-10SS	52	32	98.2	39	22.5	94.2	7.64	116.5
AWA 5-3-12SS	52	32	123.2	39	22.5	119.2	6.63	142.5
AWA 6-6- 7SS	61	61	68	47	51	64	4.41	156
AWA 6-6-10SS	61	61	98	47	51	94	3.5	212
AWA 6-6-14SS	61	61	138	47	51	134	2.83	286
AWA 6-6-19SS	61	61	188	47	51	184	2.33	379
AWA 6-6-24SS	61	61	238	47	51	234	2.02	471.5
AWA 8-4- 8SS	76	41	78	62	31	74	5.97	154
AWA 8-4-10SS	76	41	103	62	31	99	5.01	195
AWA 8-4-13SS	76	41	128	62	31	124	4.37	236.5
AWA 8-4-16SS	76	41	163	62	31	159	3.76	294
AWA 8-8- 9SS	82	82	86	66.5	66.5	81	3.1	319.5
AWA 8-8-11SS	82	82	111	66.5	66.5	106	2.63	392.5
AWA 8-8-16SS	82	82	156	66.5	66.5	151	2.12	523.5
AWA 8-8-21SS	82	82	206	66.5	66.5	201	1.79	669.5
AWA 8-8-26SS	82	82	261	66.5	66.5	256	1.54	829.5
AWA10-5-10SS	102	52	95.6	86.5	36.5	90.6	4.52	288.5
AWA10-5-14SS	102	52	135.6	86.5	36.5	130.6	3.62	387.5
AWA10-5-18SS	102	52	175.6	86.5	36.5	170.6	3.08	486
AWA10-5-23SS	102	52	225.6	86.5	36.5	220.6	2.64	609
AWA12-7- 9SS	115.7	67	90.6	100.2	51.5	85.6	3.6	354
AWA12-7-12SS	115.7	67	125.6	100.2	51.5	120.6	2.93	460
AWA12-7-17SS	115.7	67	165.1	100.2	51.5	160.1	2.47	579.5
AWA12-7-20SS	115.7	67	200.6	100.2	51.5	195.6	2.18	687
AWA15-8-12SS	152	77	120.6	136.5	61.5	115.6	2.64	565.5
AWA15-8-16SS	152	77	160.6	136.5	61.5	155.6	2.2	712
AWA15-8-21SS	152	77	210.6	136.5	61.5	205.6	1.86	895.5
AWA15-8-26SS	152	77	260.6	136.5	61.5	255.6	1.63	1,079
AWA20-8-15SS	202.4	77.4	153.8	186.5	61.5	147.8	2.3	854.5
AWA20-8-19SS	202.4	77.4	193.8	186.5	61.5	187.8	1.99	1,025
AWA20-8-24SS	202.4	77.4	243.8	186.5	61.5	237.8	1.72	1,238
AWA20-8-29SS	202.4	77.4	293.8	186.5	61.5	287.8	1.54	1,451.5

AW/AWN/AWP16-9-□
AWA15-8-□

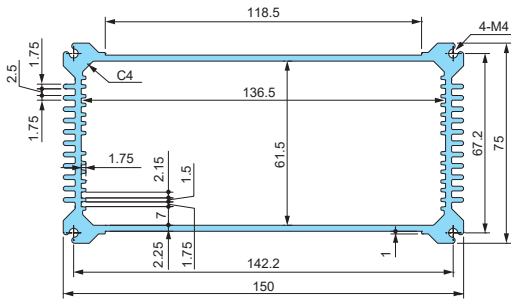

AW/AWN/AWP21-9-□
AWA20-8-□

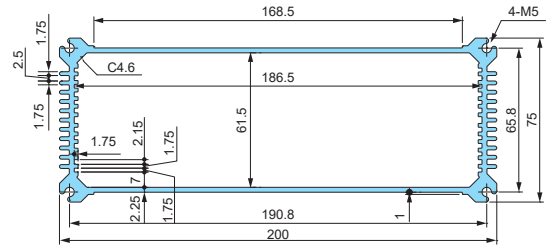

- ※ Thermal resistance test condition
- Ambient air cooling
 - Heat-sink fins are set perpendicular to the ground with temperature at 60°C.
 - Anodized aluminium extrusion
 - Heat source is applied on the opposite side (inner side) of the fins.

Product no.				Frame	※Thermal resistance rate (°C/W)
AW 5-4- 7	AWN 5-4- 7	—	AWA 5-3- 5	49.2	11.2
AW 5-4- 9	AWN 5-4- 9	—	AWA 5-3- 7	69.2	9.18
AW 5-4-11	AWN 5-4-11	—	AWA 5-3-10	94.2	7.64
AW 5-4-14	AWN 5-4-14	—	AWA 5-3-12	119.2	6.63
AW 7-7- 8	AWN 7-7- 8	AWP 7-7- 8	AWA 6-6- 7	64	4.41
AW 7-7-11	AWN 7-7-11	AWP 7-7-11	AWA 6-6-10	94	3.5
AW 7-7-15	AWN 7-7-15	AWP 7-7-15	AWA 6-6-14	134	2.83
AW 7-7-20	AWN 7-7-20	AWP 7-7-20	AWA 6-6-19	184	2.33
AW 7-7-25	AWN 7-7-25	AWP 7-7-25	AWA 6-6-24	234	2.02
AW 8-5- 9	AWN 8-5- 9	AWP 8-5- 9	AWA 8-4- 8	74	5.97
AW 8-5-12	AWN 8-5-12	AWP 8-5-12	AWA 8-4-10	99	5.01
AW 8-5-14	AWN 8-5-14	AWP 8-5-14	AWA 8-4-13	124	4.37
AW 8-5-18	AWN 8-5-18	AWP 8-5-18	AWA 8-4-16	159	3.76
AW 9-9-10	AWN 9-9-10	AWP 9-9-10	AWA 8-8- 9	81	3.1
AW 9-9-13	AWN 9-9-13	AWP 9-9-13	AWA 8-8-11	106	2.63
AW 9-9-17	AWN 9-9-17	AWP 9-9-17	AWA 8-8-16	151	2.12
AW 9-9-22	AWN 9-9-22	AWP 9-9-22	AWA 8-8-21	201	1.79
AW 9-9-28	AWN 9-9-28	AWP 9-9-28	AWA 8-8-26	256	1.54
AW11-6-11	AWN11-6-11	AWP11-6-11	AWA10-5-10	90.6	4.52
AW11-6-15	AWN11-6-15	AWP11-6-15	AWA10-5-14	130.6	3.62
AW11-6-19	AWN11-6-19	AWP11-6-19	AWA10-5-18	170.6	3.08
AW11-6-24	AWN11-6-24	AWP11-6-24	AWA10-5-23	220.6	2.64
AW12-8-11	AWN12-8-11	AWP12-8-11	AWA12-7- 9	85.6	3.6
AW12-8-14	AWN12-8-14	AWP12-8-14	AWA12-7-12	120.6	2.93
AW12-8-17	AWN12-8-17	AWP12-8-17	AWA12-7-17	160.1	2.47
AW12-8-22	AWN12-8-22	AWP12-8-22	AWA12-7-20	195.6	2.18
AW16-9-14	AWN16-9-14	AWP16-9-14	AWA15-5-12	115.6	2.64
AW16-9-18	AWN16-9-18	AWP16-9-18	AWA15-8-16	155.6	2.2
AW16-9-23	AWN16-9-23	AWP16-9-23	AWA15-8-21	205.6	1.86
AW16-9-28	AWN16-9-28	AWP16-9-28	AWA15-8-26	255.6	1.63
AW21-9-17	AWN21-9-17	AWP21-9-17	AWA20-8-15	147.8	2.3
AW21-9-21	AWN21-9-21	AWP21-9-21	AWA20-8-19	187.8	1.99
AW21-9-26	AWN21-9-26	AWP21-9-26	AWA20-8-24	237.8	1.72
AW21-9-31	AWN21-9-31	AWP21-9-31	AWA20-8-29	287.8	1.54

AWC SERIES

ALUMINIUM MOUNTING PLATE

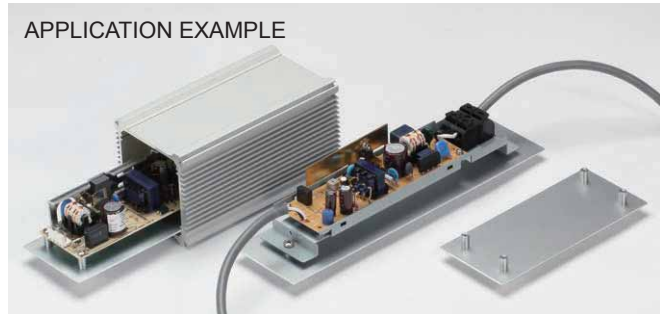
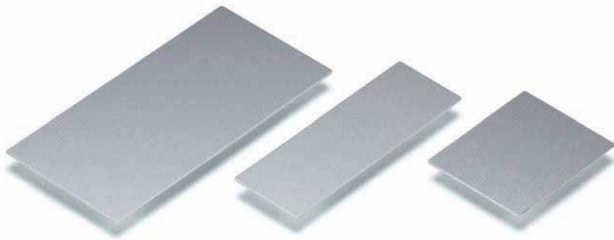

- Material: Aluminium A1050P t=1.5 / Silver anodized
- Mounting plate for AW, AWN, AWP, and AWA series enclosures.
- Utilize for mounting PCB, power supply, terminal blocks, etc.

■ DXF/DWG/PDF drawings available on our website.

Product no. / Dimensions

Product no.	W	D	Suitable enclosure
AWC 5- 7	38.9	49.2	AW • AWN 5-4-7 • AWA 5-3-5
AWC 5- 9	38.9	69.2	AW • AWN 5-4-9 • AWA 5-3-7
AWC 5-11	38.9	94.2	AW • AWN 5-4-11 • AWA 5-3-10
AWC 5-14	38.9	119.2	AW • AWN 5-4-14 • AWA 5-3-12
AWC 7- 8	47	64	AW • AWN • AWP 7-7-8 • AWA 6-6- 7
AWC 7-11	47	94	AW • AWN • AWP 7-7-11 • AWA 6-6-10
AWC 7-15	47	134	AW • AWN • AWP 7-7-15 • AWA 6-6-14
AWC 7-20	47	184	AW • AWN • AWP 7-7-20 • AWA 6-6-19
AWC 7-25	47	234	AW • AWN • AWP 7-7-25 • AWA 6-6-24
AWC 8- 9	61.8	74	AW • AWN • AWP 8-5-9 • AWA 8-4-8
AWC 8-12	61.8	99	AW • AWN • AWP 8-5-12 • AWA 8-4-10
AWC 8-14	61.8	124	AW • AWN • AWP 8-5-14 • AWA 8-4-13
AWC 8-18	61.8	159	AW • AWN • AWP 8-5-18 • AWA 8-4-16
AWC 9-10	66.5	81	AW • AWN • AWP 9-9-10 • AWA 8-8-9
AWC 9-13	66.5	106	AW • AWN • AWP 9-9-13 • AWA 8-8-11
AWC 9-17	66.5	151	AW • AWN • AWP 9-9-17 • AWA 8-8-16
AWC 9-22	66.5	201	AW • AWN • AWP 9-9-22 • AWA 8-8-21
AWC 9-28	66.5	256	AW • AWN • AWP 9-9-28 • AWA 8-8-26
AWC11-11	86.5	90.6	AW • AWN • AWP11-6-11 • AWA10-5-10
AWC11-15	86.5	130.6	AW • AWN • AWP11-6-15 • AWA10-5-14
AWC11-19	86.5	170.6	AW • AWN • AWP11-6-19 • AWA10-5-18
AWC11-24	86.5	220.6	AW • AWN • AWP11-6-24 • AWA10-5-23
AWC12-11	100.2	85.6	AW • AWN • AWP12-8-11 • AWA12-7-9
AWC12-14	100.2	120.6	AW • AWN • AWP12-8-14 • AWA12-7-12
AWC12-17	100.2	160.1	AW • AWN • AWP12-8-17 • AWA12-7-17
AWC12-22	100.2	195.6	AW • AWN • AWP12-8-22 • AWA12-7-20
AWC16-14	136.3	115.6	AW • AWN • AWP16-9-14 • AWA15-8-12
AWC16-18	136.3	155.6	AW • AWN • AWP16-9-18 • AWA15-8-16
AWC16-23	136.3	205.6	AW • AWN • AWP16-9-23 • AWA15-8-21
AWC16-28	136.3	255.6	AW • AWN • AWP16-9-28 • AWA15-8-26
AWC21-17	186.1	147.8	AW • AWN • AWP21-9-17 • AWA20-8-15
AWC21-21	186.1	187.8	AW • AWN • AWP21-9-21 • AWA20-8-19
AWC21-26	186.1	237.8	AW • AWN • AWP21-9-26 • AWA20-8-24
AWC21-31	186.1	287.8	AW • AWN • AWP21-9-31 • AWA20-8-29

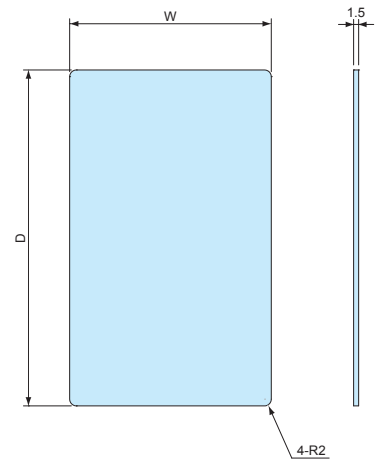

HCS SERIES

HEXAGON SOCKET HEAD SCREW

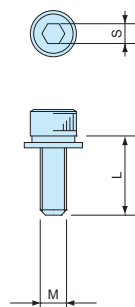

- Hexagon socket head screws for fastening the end panels of AW and AWN enclosures.
- Utilize for tamper-resistance functionality or for an elegant sleek look.

Product no. / Dimensions

Product no.	M	L	S	Material	Pack of
HCS3-12S	3	12	2.5	Stainless steel	8
HCS4-12S	4	12	3	Stainless steel	8
HCS5-12S	5	12	4	Stainless steel	8



Variations of HY series, HYR and HYRH series are also available. See website for more details.

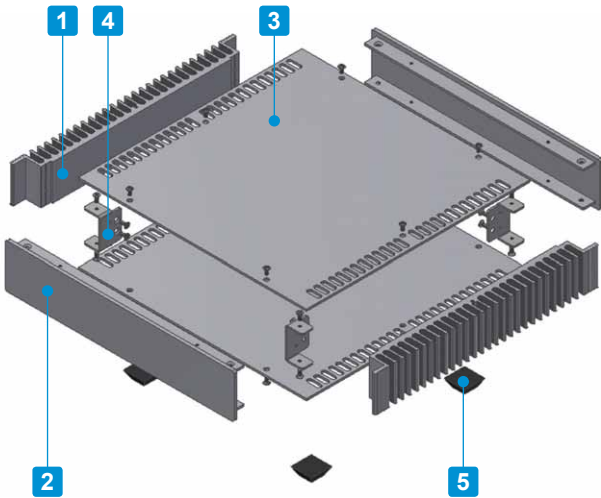

- Stylish and elegantly designed with a hairline finish.
- Excellent cooling performance with the heat-sink side plates.
- Now available in 56 sizes, and 2 different colors.
- Tough and robust enclosure from using aluminium extrusion parts.
- Simple and easy to assemble construction.
- Flat back heat-sink plates for more effective heat spreading.

Included screws

BB color type

M3-6 countersunk • Black trivalent chromate x 16 pcs
M3-5 Slotted raised countersunk • Black trivalent chromate x 12 pcs

SS color type

M3-6 countersunk • Nickel plated x 16 pcs
M3-5 Slotted raised countersunk • Nickel plated x 12 pcs

Components

No.	Part name	Pcs	Material	Color / Finish
1	Heat-sink side plate	2	Extruded aluminium A6063S-T5	Silver • Black / Anodized
2	Panel	2	Extruded aluminium A6063S-T5	Silver • Black / Hairline brushed & Anodized
3	Top • Bottom cover	2	Aluminium A1050P t=2.0	Silver • Black / Hairline brushed & Anodized
4	Corner support	4	Steel SPCC t=1.6	Trivalent chromate
5	Rubber feet	4	Polyurethane	Black

※HL = Hairline brushed

Accessories (Optional parts)



Mounting plate HYC series
See page HYC • HYCL-1



L-bracket HYCL series
See page HYC • HYCL-1



Aluminium isolation feet AFS • AFM series
See page AFS • AFM-1 ~ 2



TORX screw - for top / bottom cover MR3-5Z series
See page HY • HYR • HYRH-2



■ Drawings below are reference examples only.
DXF/DWG/PDF drawings available on our website.

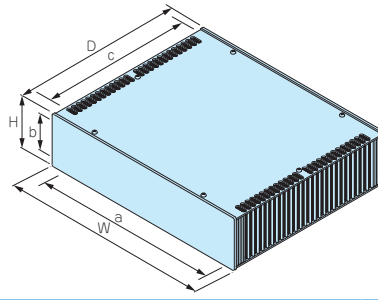

Product no.		Dimensions (External)			Dimensions (Internal)			Weight (kg)
● Silver	● Black	W	H	D	a	b	c	
HY 44-23-23SS	HY 44-23-23BB	230	44	231	186	36	225	1.1
HY 44-23-33SS	HY 44-23-33BB	230	44	330	186	36	324	1.6
HY 44-28-23SS	HY 44-28-23BB	280	44	231	196	36	225	1.4
HY 44-28-33SS	HY 44-28-33BB	280	44	330	196	36	324	1.9
HY 44-33-23SS	HY 44-33-23BB	330	44	231	286	36	225	1.5
HY 44-33-33SS	HY 44-33-33BB	330	44	330	286	36	324	2.2
HY 44-43-23SS	HY 44-43-23BB	430	44	231	386	36	225	1.9
HY 44-43-33SS	HY 44-43-33BB	430	44	330	386	36	324	2.6
HY 70-23-23SS	HY 70-23-23BB	230	70	231	186	62	225	1.6
HY 70-23-33SS	HY 70-23-33BB	230	70	330	186	62	324	2.2
HY 70-28-23SS	HY 70-28-23BB	280	70	231	196	62	225	1.8
HY 70-28-33SS	HY 70-28-33BB	280	70	330	196	62	324	2.5
HY 70-33-23SS	HY 70-33-23BB	330	70	231	286	62	225	2.0
HY 70-33-33SS	HY 70-33-33BB	330	70	330	286	62	324	2.8
HY 70-43-23SS	HY 70-43-23BB	430	70	231	386	62	225	2.3
HY 70-43-33SS	HY 70-43-33BB	430	70	330	386	62	324	3.2
HY 88-23-23SS	HY 88-23-23BB	230	88	231	186	80	225	1.9
HY 88-23-33SS	HY 88-23-33BB	230	88	330	186	80	324	2.6
HY 88-28-23SS	HY 88-28-23BB	280	88	231	196	80	225	2.1
HY 88-28-33SS	HY 88-28-33BB	280	88	330	196	80	324	2.8
HY 88-33-23SS	HY 88-33-23BB	330	88	231	286	80	225	2.3
HY 88-33-33SS	HY 88-33-33BB	330	88	330	286	80	324	3.1
HY 88-43-23SS	HY 88-43-23BB	430	88	231	386	80	225	2.7
HY 88-43-33SS	HY 88-43-33BB	430	88	330	386	80	324	3.6
HY 99-23-23SS	HY 99-23-23BB	230	99	231	186	91	225	2.1
HY 99-23-33SS	HY 99-23-33BB	230	99	330	186	91	324	2.7
HY 99-28-23SS	HY 99-28-23BB	280	99	231	196	91	225	2.3
HY 99-28-33SS	HY 99-28-33BB	280	99	330	196	91	324	3.1
HY 99-33-23SS	HY 99-33-23BB	330	99	231	286	91	225	2.5
HY 99-33-33SS	HY 99-33-33BB	330	99	330	286	91	324	3.4
HY 99-43-23SS	HY 99-43-23BB	430	99	231	386	91	225	2.9
HY 99-43-33SS	HY 99-43-33BB	430	99	330	386	91	324	3.9
HY133-23-23SS	HY133-23-23BB	230	132.5	231	186	124.5	225	2.6
HY133-23-33SS	HY133-23-33BB	230	132.5	330	186	124.5	324	3.4
HY133-28-23SS	HY133-28-23BB	280	132.5	231	196	124.5	225	2.8
HY133-28-33SS	HY133-28-33BB	280	132.5	330	196	124.5	324	3.8
HY133-33-23SS	HY133-33-23BB	330	132.5	231	286	124.5	225	3.0
HY133-33-33SS	HY133-33-33BB	330	132.5	330	286	124.5	324	4.1
HY133-43-23SS	HY133-43-23BB	430	132.5	231	386	124.5	225	3.5
HY133-43-33SS	HY133-43-33BB	430	132.5	330	386	124.5	324	4.7
HY149-23-23SS	HY149-23-23BB	230	149	231	186	141	225	2.8
HY149-23-33SS	HY149-23-33BB	230	149	330	186	141	324	3.8
HY149-28-23SS	HY149-28-23BB	280	149	231	196	141	225	3.1
HY149-28-33SS	HY149-28-33BB	280	149	330	196	141	324	4.2
HY149-33-23SS	HY149-33-23BB	330	149	231	286	141	225	3.3
HY149-33-33SS	HY149-33-33BB	330	149	330	286	141	324	4.5
HY149-43-23SS	HY149-43-23BB	430	149	231	386	141	225	3.8
HY149-43-33SS	HY149-43-33BB	430	149	330	386	141	324	5.1
HY177-23-23SS	HY177-23-23BB	230	177	231	186	169	225	3.4
HY177-23-33SS	HY177-23-33BB	230	177	330	186	169	324	4.5
HY177-28-23SS	HY177-28-23BB	280	177	231	196	169	225	3.6
HY177-28-33SS	HY177-28-33BB	280	177	330	196	169	324	4.8
HY177-33-23SS	HY177-33-23BB	330	177	231	286	169	225	3.9
HY177-33-33SS	HY177-33-33BB	330	177	330	286	169	324	5.2
HY177-43-23SS	HY177-43-23BB	430	177	231	386	169	225	4.5
HY177-43-33SS	HY177-43-33BB	430	177	330	386	169	324	5.8

HY SERIES APPLICATION EXAMPLE

COMPLETE BALANCED SPECIAL TUNED DC HEADPHONE AMPLIFIER

Product by Sanyo Kasei (Japan)



ENERGY CREATION POWER CONDITIONER DEVELOPMENT KIT

Product by Smart Energy Laboratory (Japan)



LINEAR POWER SUPPLY

Product by UpTone Audio (USA)

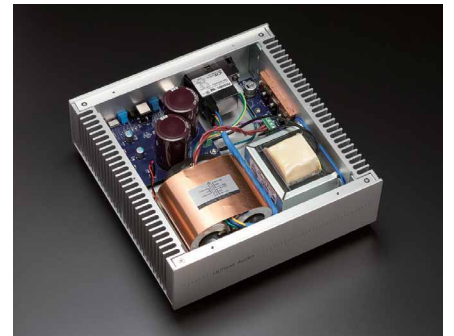

INDUSTRIAL FANLESS COMPUTER

Product by Techno Veins (Japan)



HY dimensions (outside view)

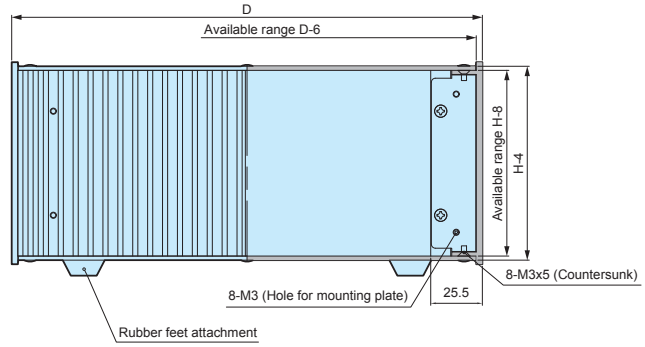
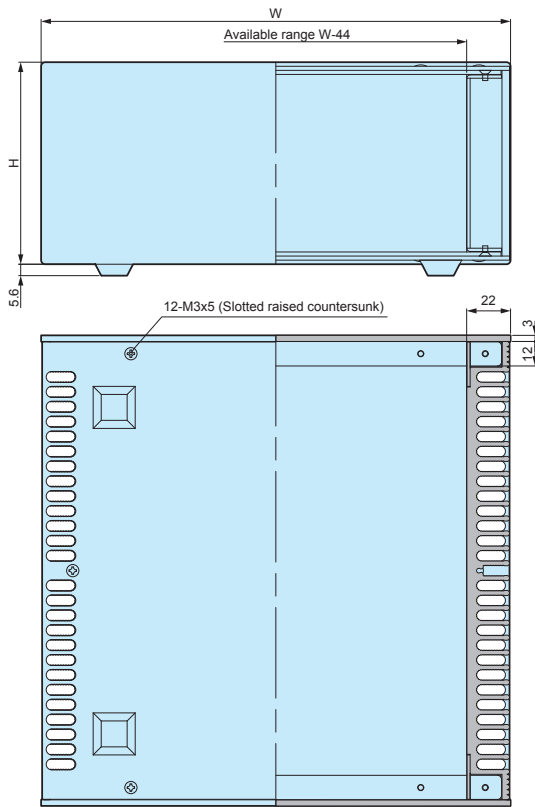

Included screws

BB Color type

M3-6 countersunk screw, black trivalent chromate x 16 pcs

M3-5 Slotted raised countersunk screw, black trivalent chromate x 12 pcs

SS Color type

M3-6 countersunk screw, nickel plated x 16 pcs

M3-5 Slotted raised countersunk screw, nickel plated x 12 pcs

Component Parts Drawings

HY • HYR • HYRH top / bottom cover

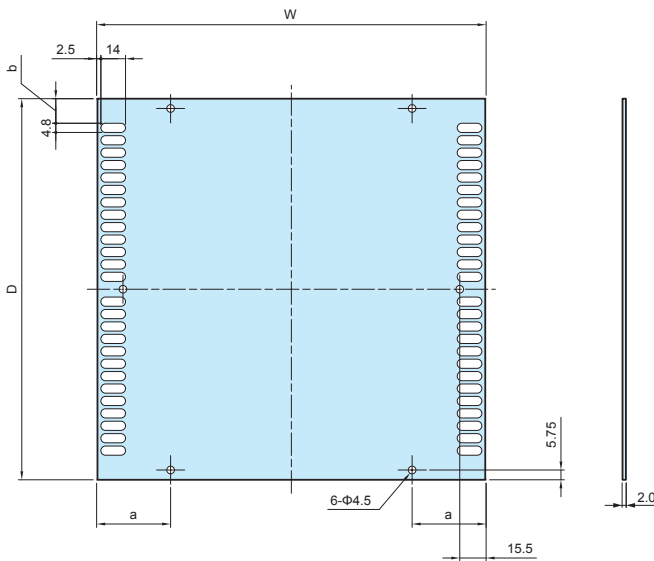

Color Type

Code	Material	Color / Finish
SS	Aluminium A1050P t = 2.0	Silver / Hairline brushed & Anodized
BB	Aluminium A1050P t = 2.0	Black / Hairline brushed & Anodized

Dimensions

Enclosure W x D	W	D	a	b
230 x 231	229	224.5	45.7	14.95
230 x 330	229	323.5	45.7	15.1
280 x 231	279	224.5	55.8	14.95
280 x 330	279	323.5	55.8	15.1
330 x 231	329	224.5	65.8	14.95
330 x 330	329	323.5	65.8	15.1
430 x 231	429	224.5	85.8	14.95
430 x 330	429	323.5	85.8	15.1

HY front / rear panels & HYR • HYRH rear panel

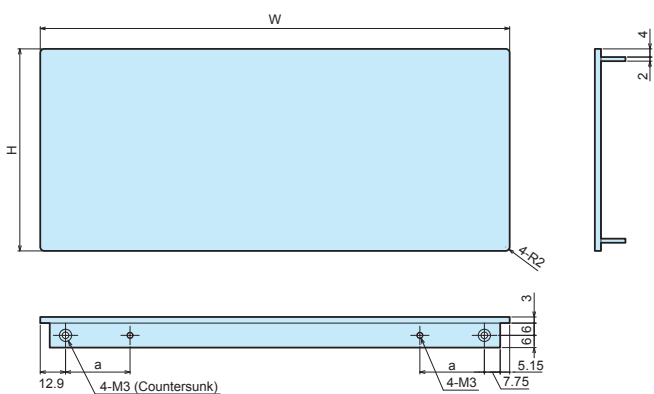

Color Type

Code	Material	Color / Finish
SS	Extruded aluminium A6063S-T5	Silver / Hairline brushed & Anodized
BB	Extruded aluminium A6063S-T5	Black / Hairline brushed & Anodized

Dimensions

Enclosure W	W	a	H(44)	H(70)	H(88)	H(99)	H(132.5)	H(149)	H(177)
230	230	33.3	44	70	88	99	132.5	149	177
280	280	43.4	44	70	88	99	132.5	149	177
330	330	53.4	44	70	88	99	132.5	149	177
430	430	73.4	44	70	88	99	132.5	149	177

HY • HYR • HYRH heat-sink side plate

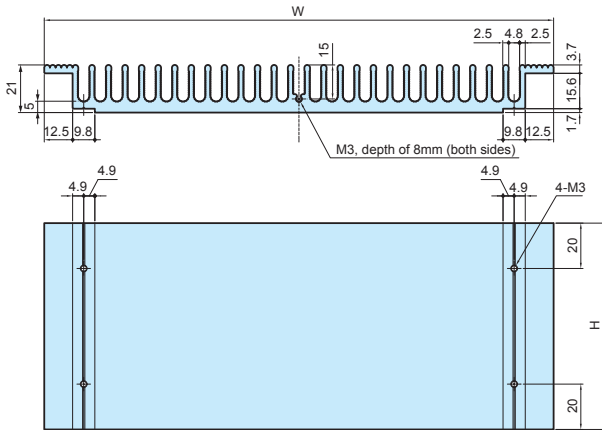

Color Type

Code	Material	Color / Finish
SS	Extruded aluminium A6063S-T5	Silver / Anodized
BB	Extruded aluminium A6063S-T5	Black / Anodized

Dimensions

Enclosure D x H	W	H	Thermal resistance (°C/W)
231 × 44	224.6	36	2.41
330 × 44	323.6	36	1.89
231 × 70	224.6	62	1.49
330 × 70	323.6	62	1.36
231 × 88	224.6	80	1.49
330 × 88	323.6	80	1.17
231 × 99	224.6	91	1.38
330 × 99	323.6	91	1.08
231 × 132.5	224.6	124.5	1.14
330 × 132.5	323.6	124.5	0.89
231 × 149	224.6	141	1.06
330 × 149	323.6	141	0.83
231 × 177	224.6	169	0.95
330 × 177	323.6	169	0.74

■ Thermal resistance calculation is based on the fins being perpendicular to the ground with temperature at 60°C.

HY • HYR • HYRH corner support

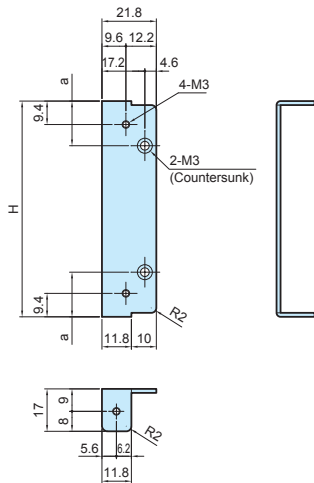

Part Information

Part name	Material	Finish
Corner support	Steel t=1.6	Trivalent chromate

Dimensions

Enclosure H	H	a
44	31.8	10.9
70	57.8	17.9
88	75.8	17.9
99	86.8	17.9
132.5	120.3	17.9
149	136.8	17.9
177	164.8	17.9

HY • HYR • HYRH rubber feet

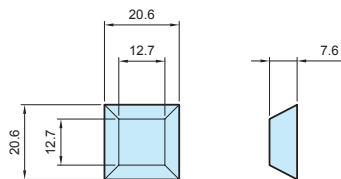

Part Information

Part name	Material	Color
Rubber feet	Polyurethane	Black

Accessories (Optional parts)

MR SERIES

SLOTTED RAISED COUNTERSUNK TORX SCREW



- For use with top/bottom cover.
- Recommended for aesthetic purposes, or for tampering resistance.
- Requires the use of a specialized screwdriver.

Product no. / Dimensions

Product no.	M	L	TORX head no.	Material	Color / Finish	Pack of
MR3-5ZS	3	5	T10	Steel	Nickel plated	20
MR3-5ZB	3	5	T10	Steel	Black trivalent chromate	20

HYC SERIES

MOUNTING PLATE for HY · HYR · HYRH

■ Mounting plate and L-bracket set.

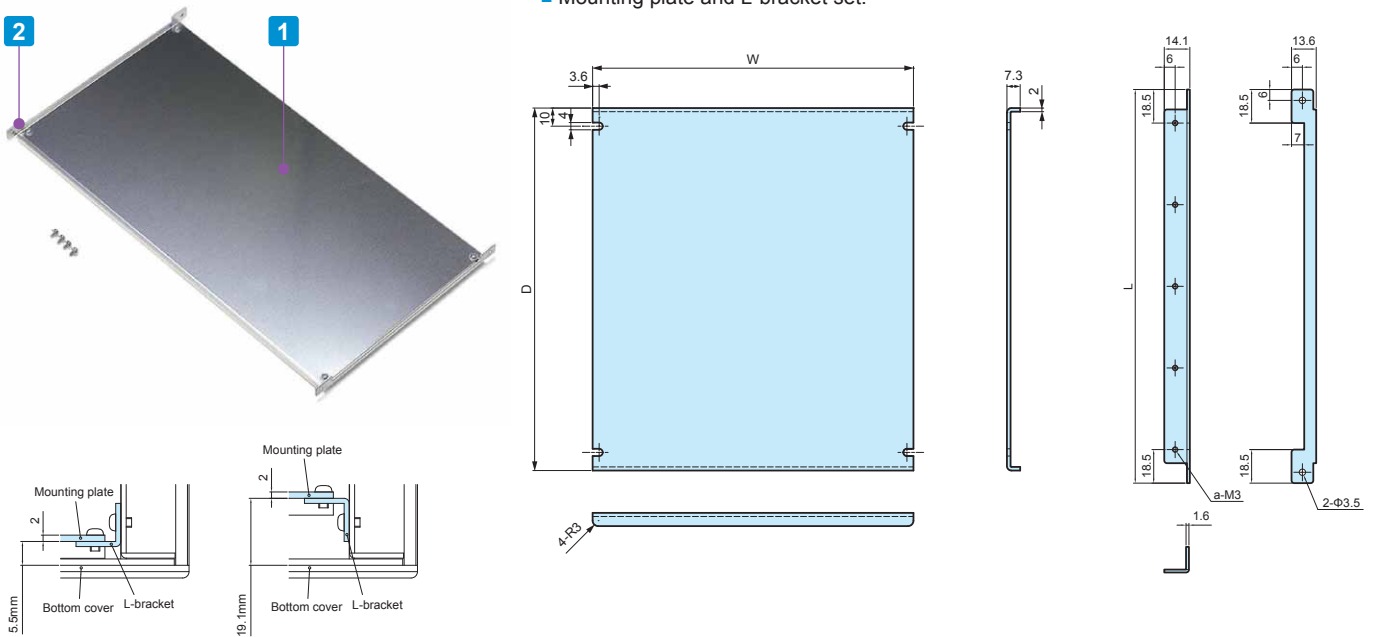

Components

No.	Part name	Pcs	Material	Color / Finish
1	Mounting plate	1	Aluminium A1050P t=2.0	Unfinished
2	L-bracket	2	Steel SPCC t=1.6	Tivalent chromate
?	Screw	1 set	Steel M3	Tivalent chromate

Product no. / Dimensions

Product no.	W	D	L	a	Suitable models	Weight (g)
HYC23-23	177	200	217	5	HY□-23-23	300
HYC23-28	227	200	217	5	HY□-28-23	350
HYC23-33	277	200	217	5	HY□-33-23	410
HYC23-43	377	200	217	5	HY□-43-23	520
HYC33-23	177	299	316	7	HY□-23-33	450
HYC33-28	227	299	316	7	HY□-28-33	550
HYC33-33	277	299	316	7	HY□-33-33	710
HYC33-43	377	299	316	7	HY□-43-33	800



Clinching stud customization service available.

HYCL SERIES

L-bracket for HY · HYR · HYRH

- Simple L-bracket and screw set.
- Use with your original mounting plate or PCB.

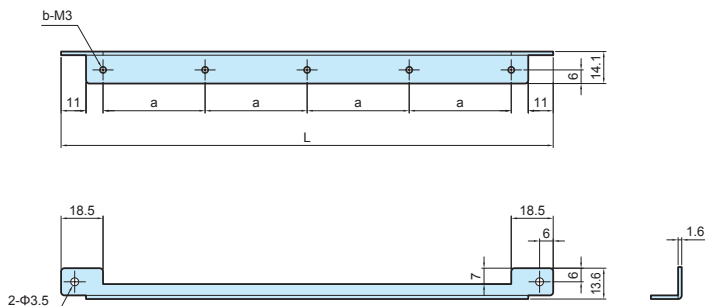

Components

No.	Part name	Material	Color / Finish
1	L-bracket	Steel t=1.6	Tivalent chromate
2	Screw	Steel M3	Tivalent chromate

Product no. / Dimensions

Product no.	L	a	b	Pack of
HYCL-23	217	45	5	2
HYCL-33	316	46.5	7	2



- Heat dissipation and cooling via the utilization of extruded aluminium heat-sink side plates.
- Rounded corners gives it an elegant feel.
- Aluminium extrusion parts provides high structural durability.
- Suitable for use as small-type fanless PC, digital audio equipment, and so on.
- Available in both Silver and Black color types.

- Optional aluminium isolation feet, AFS and AFM series are available. See page AFS•AFM-1 ~ AFS•AFM-2 for more details.

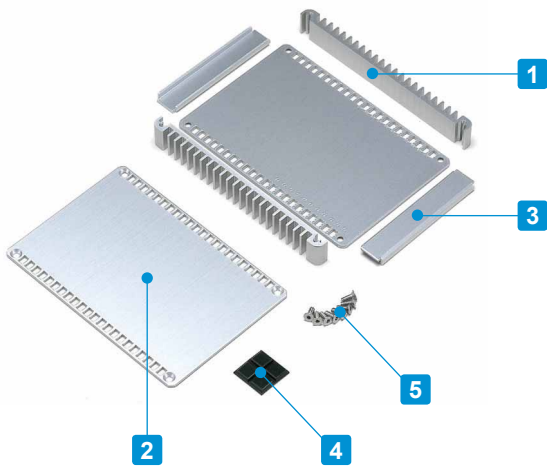

Application example



Included screws
 Enclosure (Silver) M3-8 Hexagonal countersunk : Stainless steel : Unfinished x 8 pcs
 Enclosure (Black) M3-8 Hexagonal countersunk : Steel : Black trivalent chromate x 8 pcs
 ※Hexagonal wrench included

Components

No.	Part name	Pcs	Material	Color / Finish
1	Heat-sink side plate	2	Extruded aluminium A6063S-T5	Silver • Black / Anodized
2	Top • Bottom cover	2	Aluminium A1050P t=2.0	Silver • Black / Hairline brushed & Anodized
3	Front • Rear panel	2	Aluminium A1050P t=1.5	Silver • Black / Hairline brushed & Anodized
4	Rubber feet	1 set	Polyurethane	Black
5	Screw	8	Stainless steel (SS color type) Steel (BB color type)	Unfinished Black trivalent chromate (Steel)

HIT dimensions

■ Drawings below are reference examples only.
DXF/DWG/PDF drawings available on our website.

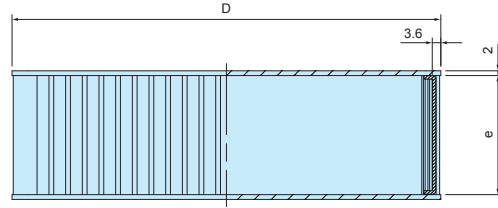
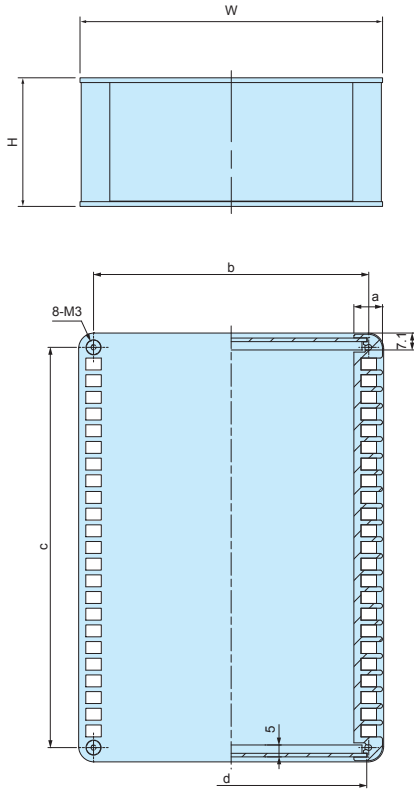

APPLICATION EXAMPLE

FIBER OPTICS EXTENSION UNIT

Product by Sanritz Automation (Japan)



AUDIO POWER SUPPLY for MacBook

Product by AY-densi (Japan)



Product no. / Dimensions

■ Thermal resistance calculation is based on the fins being perpendicular to the ground with temperature at 60°C.

Product no.		W	H	D	a	b	c	d	e	※ Thermal resistance rate (°C/W)	Weight (g)
● Silver	● Black										
HIT 9-2-13SS	HIT 9-2-13BB	89	20	130	8	81	118.6	78.8	16	9.14	183
HIT 9-4-13SS	HIT 9-4-13BB	89	40	130	8	81	118.6	78.8	36	5.6	255
HIT13-3-13SS	HIT13-3-13BB	130	30	130	8	122	118.6	119.8	26	6.82	289
HIT13-5-13SS	HIT13-5-13BB	130	50	130	8	122	118.6	119.8	46	4.83	370
HIT18-4-13SS	HIT18-4-13BB	180	40	130	8	172	118.6	169.8	36	5.6	414
HIT18-6-13SS	HIT18-6-13BB	180	60	130	8	172	118.6	169.8	56	4.29	503
HIT13-3-18SS	HIT13-3-18BB	128	30	180	12	115.5	168	113.8	26	4.38	411
HIT13-5-18SS	HIT13-5-18BB	128	50	180	12	115.5	168	113.8	46	3.1	535
HIT17-4-18SS	HIT17-4-18BB	174	40	180	12	161.5	168	159.8	36	3.6	578
HIT17-6-18SS	HIT17-6-18BB	174	60	180	12	161.5	168	159.8	56	2.76	719
HIT23-5-18SS	HIT23-5-18BB	228	50	180	12	215.5	168	213.8	46	3.1	772
HIT23-7-18SS	HIT23-7-18BB	228	70	180	12	215.5	168	213.8	66	2.5	928



Heat Resistant



- Aluminium case with heat dissipating heat-sink cover for superior cooling effect.
- Recommended for use with equipment requiring heat dissipation.
- Manufactured with mounting flange for easy attachment onto walls and other surfaces.

APPLICATION EXAMPLE

HIGH-END PERFORMANCE AUDIO AMPLIFIER

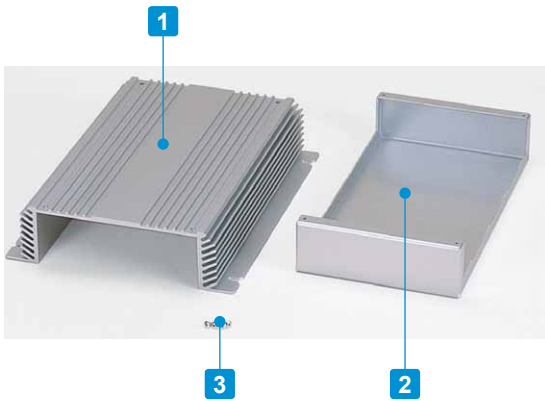

Product by: IC Technologies (Australia)

Components

No.	Part name	Pcs	Material	Color / Finish
1	Heat-sink cover	1	Extruded aluminium A6063S-T5	Silver • Black / Anodized
2	Bottom chassis	1	Aluminium A1050P t=1.5	Silver • Black / Anodized
3	Screw	4	Steel M3-5	Nickel plated • Black trivalent chromate

HS dimensions

■ Drawings below are reference examples only.
DXF/DWG/PDF drawings available on our website.

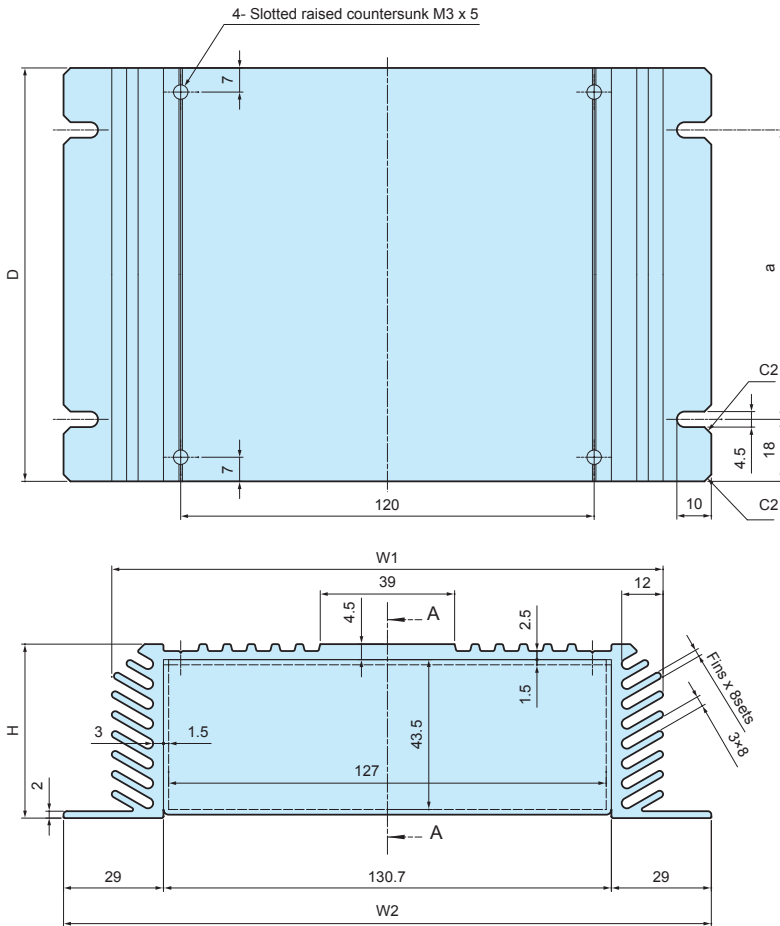

A-A cross-section

Product no. / Dimensions

Product no.		W1	W2	H	D	a	Thermal resistance (°C / W)	Weight (kg)
● Silver	● Black							
HS16-5-16S	HS16-5-16B	160	188.7	50.5	160	124	1.1	0.72
HS16-5-23S	HS16-5-23B	160	188.7	50.5	230	194	0.83	1.0
HS16-5-30S	HS16-5-30B	160	188.7	50.5	300	264	0.69	1.29

■ Thermal resistance calculation is based on the fins being perpendicular to the ground with temperature at 60°C.

Accessories (Optional parts)

MR SERIES

SLOTTED RAISED COUNTERSUNK TORX SCREW



- For use with the heat-sink cover.
- Recommended for aesthetic purposes, or for tampering resistance.
- Requires the use of a specialized screwdriver.

Product no. / Dimensions

Product no.	M	L	TORX head no.	Material	Color / Finish	Pack of
MR3-5ZS	3	5	T10	Steel	Nickel plated	20
MR3-5ZB	3	5	T10	Steel	Black trivalent chromate	20

HEN SERIES

HEAT-SINK ALUMINIUM CASE

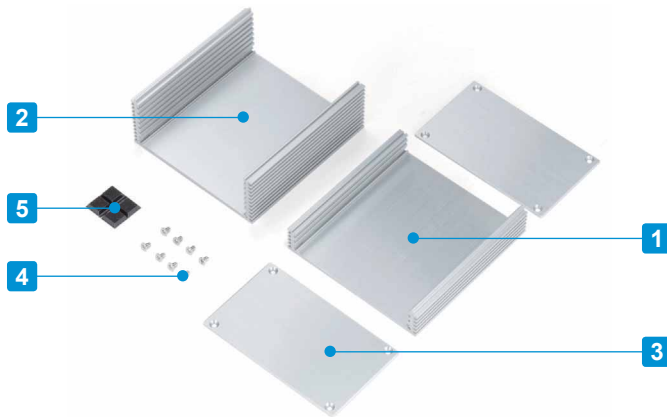

- Stylish design coupled with hairline brushed finish makes for a luxurious high-end case.
- Heat dissipation and cooling via the utilization of extruded aluminium heat-sink top/bottom cover.
- Available in 18 sizes.
- Sturdy extruded case construction.

Included screws
 Enclosure (Silver) M3-6 countersunk : Steel : Nickel plated x 8 pcs
 Enclosure (Black) M3-6 countersunk : Steel : Black trivalent chromate x 8 pcs

Components

No.	Part name	Pcs	Material	Color / Finish
1	Top cover	1	Extruded aluminium A6063S-T5	Silver • Black / Hairline brushed & Anodized
2	Bottom cover	1	Extruded aluminium A6063S-T5	Silver • Black / Hairline brushed & Anodized
3	Front • Rear panel	2	Aluminium A1050P t=2.0	Silver • Black / Hairline brushed & Anodized
4	Screw	8	Steel countersunk M3-6	Nickel plated • Black trivalent chromate
5	Rubber feet	4	Polyurethane	Black

※HL = Hairline brushed

Accessories (Optional parts)



TORX screw MR-2S
 See page EM•MR-1



Aluminium isolation feet AFS • AFM series
 See page AFS•AFM-1 ~ AFS•AFM-2

HEN dimensions

■ Drawings below are reference examples only.
DXF/DWG/PDF drawings available on our website.

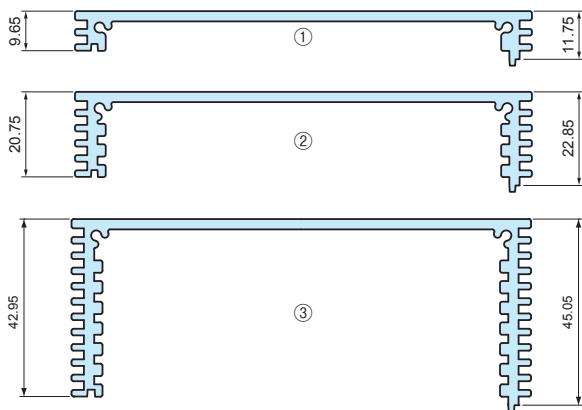
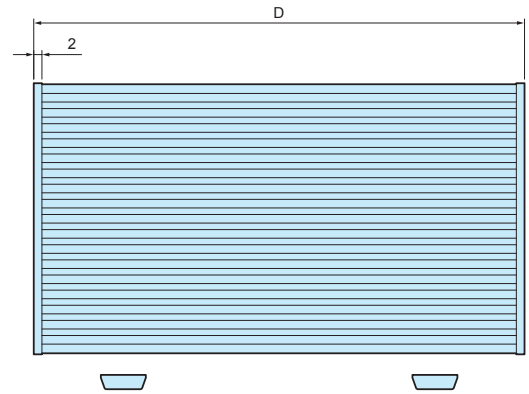
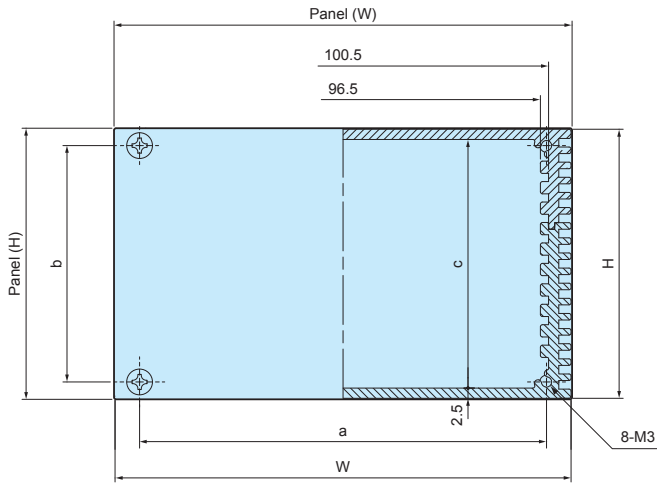

Cover Type

Cover	Cover length (D-4)	※ Thermal resistance rate (°C/W)
①	56	6.7
	116	3.6
	196	2.1
②	56	5
	116	2.6
	196	1.5
③	56	3.3
	116	1.7
	196	0.93

■ Thermal resistance calculation is based on the fins being perpendicular to the ground with temperature at 60°C.

Product no. / Dimensions

Product no.		W	H	D	Panel (W)	Panel (H)	a	b	c	Cover combination	Weight (g)
● Silver	● Black										
HEN110206S	HEN110206B	111.2	21.4	60	112	21.9	99.2	13.4	16.4	①×2	143
HEN110212S	HEN110212B	111.2	21.4	120	112	21.9	99.2	13.4	16.4		258
HEN110220S	HEN110220B	111.2	21.4	200	112	21.9	99.2	13.4	16.4		411
HEN110306S	HEN110306B	111.2	32.5	60	112	33.0	99.2	24.5	27.5	①×1 ②×1	179
HEN110312S	HEN110312B	111.2	32.5	120	112	33.0	99.2	24.5	27.5		311
HEN110320S	HEN110320B	111.2	32.5	200	112	33.0	99.2	24.5	27.5		488
HEN110406S	HEN110406B	111.2	43.6	60	112	44.1	99.2	35.6	38.6	②×2	215
HEN110412S	HEN110412B	111.2	43.6	120	112	44.1	99.2	35.6	38.6		365
HEN110420S	HEN110420B	111.2	43.6	200	112	44.1	99.2	35.6	38.6		565
HEN110506S	HEN110506B	111.2	54.7	60	112	55.2	99.2	46.7	49.7	①×1 ③×1	250
HEN110512S	HEN110512B	111.2	54.7	120	112	55.2	99.2	46.7	49.7		417
HEN110520S	HEN110520B	111.2	54.7	200	112	55.2	99.2	46.7	49.7		640
HEN110606S	HEN110606B	111.2	65.8	60	112	66.3	99.2	57.8	60.8	②×1 ③×1	286
HEN110612S	HEN110612B	111.2	65.8	120	112	66.3	99.2	57.8	60.8		471
HEN110620S	HEN110620B	111.2	65.8	200	112	66.3	99.2	57.8	60.8		717
HEN110806S	HEN110806B	111.2	88.0	60	112	88.5	99.2	80.8	83.0	③×2	358
HEN110812S	HEN110812B	111.2	88.0	120	112	88.5	99.2	80.8	83.0		577
HEN110820S	HEN110820B	111.2	88.0	200	112	88.5	99.2	80.8	83.0		869

APPLICATION EXAMPLE AUDIO POWER SUPPLY

Product by AY-densi (Japan)



AW · AWN · AWP IP67 ALUMINIUM ENCLOSURE

AW · AWN · AWP series are highly functional aluminium enclosures which are IP67 rated with heat dissipating heat-sink fins.

34 sizes available. Standard, Flanged, Shielding, and Silicone protector types are available. Suitable for LED power supply, industrial camera, controller or measuring instrument where waterproof and cooling performance are crucial.

APPLICATION EXAMPLE

LIQUID LEVEL SENSOR

Product by Watty Corporation (Japan)



HEAVY DUTY PORTABLE HARDNESS TESTER

Product by DEMEQ (Argentina)



RADIO-CONTROLLED ELECTRONIC EXPLODER

Product by CODETEL (France)



OUTDOOR LED POWER SUPPLY



OPTICAL PHASE INTERROGATOR (OPI) DEVELOPMENT KIT

Product by Broadcom Limited (USA)



FBG DATA LOGGER

Product by NAGANO KEIKI (Japan)



DATA LOGGER with 3G MODEM REPORT FUNCTION

Product by mSolution (Hong Kong)



PIN HOLE DETECTOR

Product by SANKO ELECTRONIC LABORATORY (Japan)



PD ANNUNCIATOR

Product by ndb Technologies (Canada)



DC CONVERTER



CUSTOM LENGTH AVAILABLE

Flexible frame length from 50mm to 700mm in 1mm intervals.

No minimum order quantity and short lead time for small quantity order.



AW SERIES

IP67 FLANGED ALUMINIUM ENCLOSURE



- IP67 and heat dissipation enclosure. Designed with flanged end panels.
- PCB or chassis is mounted by sliding it horizontally into an inner-grooved body frame.
- Designed for a tough environment where waterproof and heat countermeasures are required.
- Suitable for outdoor use such as LED power supply and junction boxes.

Technical Data
Protection class: IP67
Operating temperature: -40°C ~ +105°C
Recommended torque: 1.0N • m (10kgf • cm)

Normal N type Components

No.	Part name	Pcs	Material	Color / Finish
1	Flanged end panel	2	Diecast aluminium ADC12	Metallic gray • Black / Powder coated
2	Body frame	1	Extruded aluminium A6063S-T5	Silver • Black / Anodized
3	Gasket	2	Silicone	Black
4	Screw	8	Stainless steel	Unfinished

EMC Shielded E type Components

No.	Part name	Pcs	Material	Color / Finish
1	Flanged end panel	2	Diecast aluminium ADC12	Silver • Black / Painted (unfinished inside)
2	Body frame	1	Extruded aluminium A6063S-T5	Silver • Black / Anodized
3	Gasket	2	Silicone	Black
4	Screw	8	Stainless steel	Unfinished

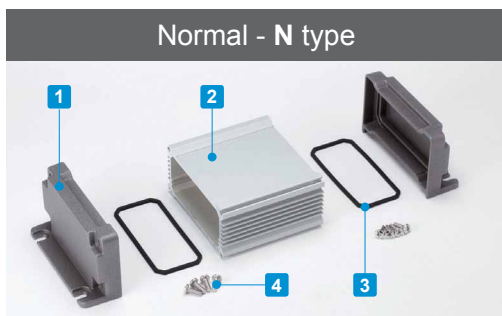

Normal - N type



Color type

Metallic gray / Silver
N G S

Black / Silver
N B S

Black / Black
N B B

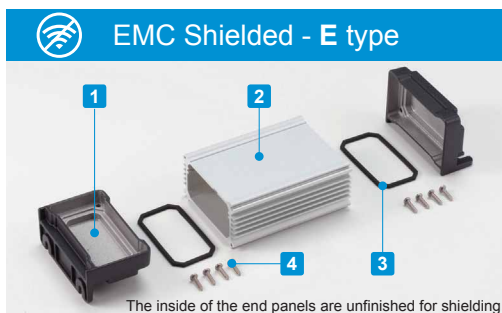

EMC Shielded - E type

The inside of the end panels are unfinished for shielding.



Color type

Silver / Silver
E S S

Black / Silver
E B S

Black / Black
E B B

AW dimensions

■ Drawings below are reference examples only.
DXF/DWG/PDF drawings available on our website.

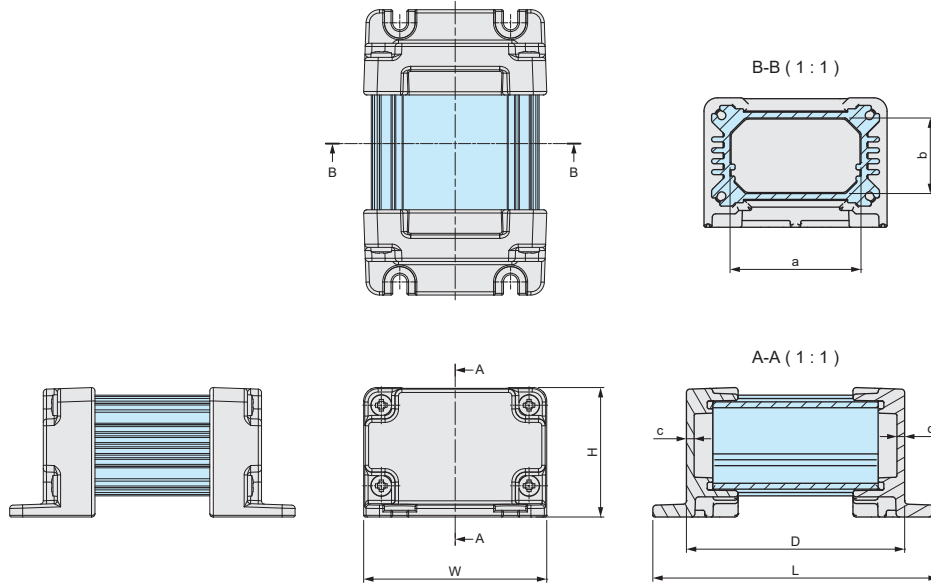

Product no. / Dimensions

■ Please suffix color code at the end of the product number.

Product no.	W	H	D	L	a	b	c	Weight (g)
AW 5-4- 7□□□	54.6	38.6	65	85	39	22.5	2.3	128.5
AW 5-4- 9□□□	54.6	38.6	85	105	39	22.5	2.3	149
AW 5-4-11□□□	54.6	38.6	110	130	39	22.5	2.3	175
AW 5-4-14□□□	54.6	38.6	135	155	39	22.5	2.3	201.5
AW 7-7- 8□□□	65.8	70.8	80	106	47	51	2.5	294.5
AW 7-7-11□□□	65.8	70.8	110	136	47	51	2.5	350
AW 7-7-15□□□	65.8	70.8	150	176	47	51	2.5	424.5
AW 7-7-20□□□	65.8	70.8	200	226	47	51	2.5	517
AW 7-7-25□□□	65.8	70.8	250	276	47	51	2.5	610
AW 8-5- 9□□□	80.8	50.8	90	116	62	31	2.5	289.5
AW 8-5-12□□□	80.8	50.8	115	141	62	31	2.5	330.5
AW 8-5-14□□□	80.8	50.8	140	166	62	31	2.5	372
AW 8-5-18□□□	80.8	50.8	175	201	62	31	2.5	429.5
AW 9-9-10□□□	86.3	92	100	129	66.5	66.5	3	560.5
AW 9-9-13□□□	86.3	92	125	154	66.5	66.5	3	633.5
AW 9-9-17□□□	86.3	92	170	199	66.5	66.5	3	764.5
AW 9-9-22□□□	86.3	92	220	249	66.5	66.5	3	910.5
AW 9-9-28□□□	86.3	92	275	304	66.5	66.5	3	1,071
AW11-6-11□□□	106.3	62	110	139	86.5	36.5	3	526.5
AW11-6-15□□□	106.3	62	150	179	86.5	36.5	3	625
AW11-6-19□□□	106.3	62	190	219	86.5	36.5	3	723.5
AW11-6-24□□□	106.3	62	240	269	86.5	36.5	3	847
AW12-8-11□□□	120	77	105	134	100.2	51.5	3	614.5
AW12-8-14□□□	120	77	140	169	100.2	51.5	3	720.5
AW12-8-17□□□	120	77	179.5	208.5	100.2	51.5	3	840
AW12-8-22□□□	120	77	215	244	100.2	51.5	3	947.5
AW16-9-14□□□	156.3	87	135	164	136.5	61.5	3	945.5
AW16-9-18□□□	156.3	87	175	204	136.5	61.5	3	1,092.5
AW16-9-23□□□	156.3	87	225	254	136.5	61.5	3	1,275.5
AW16-9-28□□□	156.3	87	275	304	136.5	61.5	3	1,459
AW21-9-17□□□	206.3	87	170	199	186.5	61.5	3	1,303
AW21-9-21□□□	206.3	87	210	239	186.5	61.5	3	1,473.5
AW21-9-26□□□	206.3	87	260	289	186.5	61.5	3	1,686.5
AW21-9-31□□□	206.3	87	310	339	186.5	61.5	3	1,899.5

Accessories (Optional parts)



Mounting plate □AWC series
See page 170



Hexagon socket head screw HCS series
See page 170



Cable gland
See cable gland pages



Pole mounting bracket SSK series
See page SSK-M-1 ~ SSK-M-3



Protective vent PMF series
See page PMF-1 ~ PMF-3

AWN SERIES

IP67 HEAT-SINK ALUMINIUM ENCLOSURE

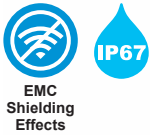

- IP67 and heat dissipation enclosure design. Selectable in both Normal or EMC Shielded type.
- The extruded aluminium frame and diecast aluminium panels makes it extremely suitable to be used in harsh environments where waterproofing and heat dissipation is essential.
- PCB or chassis can be mounted by sliding it horizontally into inner-grooved body frame.
- Suitable for measuring instruments, industrial control box, and industrial camera housing, among others.

Technical Data
Protection class: IP67
Operating temperature: -40°C ~ +105°C
Recommended torque: 1.0N • m (10kgf • cm)

Normal N type Components

No.	Part name	Pcs	Material	Color / Finish
1	End Panel	2	Diecast aluminium ADC12	Metallic gray • Black / Powder coated
2	Body frame	1	Extruded aluminium A6063S-T5	Silver • Black / Anodized
3	Gasket	2	Silicone	Black
4	Screw	8	Stainless steel	Unfinished
5	Rubber feet	4	Polyurethane	Black

EMC Shielded E type Components

No.	Part name	Pcs	Material	Color / Finish
1	End Panel	2	Diecast aluminium ADC12	Silver • Black / Painted (unfinished inside)
2	Body frame	1	Extruded aluminium A6063S-T5	Silver • Black / Anodized
3	Gasket	2	Silicone	Black
4	Screw	8	Stainless steel	Unfinished
5	Rubber feet	4	Polyurethane	Black

Normal - N type

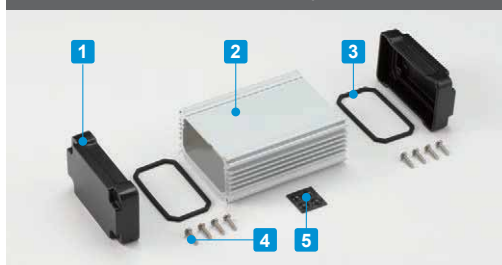

Color type



EMC Shielded - E type

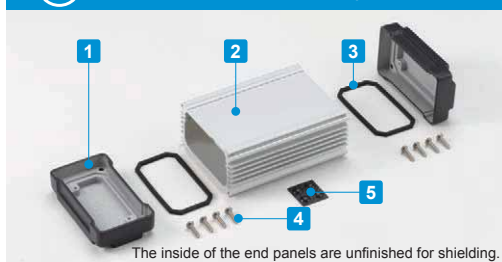

Color type



AWN dimensions

■ Drawings below are reference examples only.
DXF/DWG/PDF drawings available on our website.

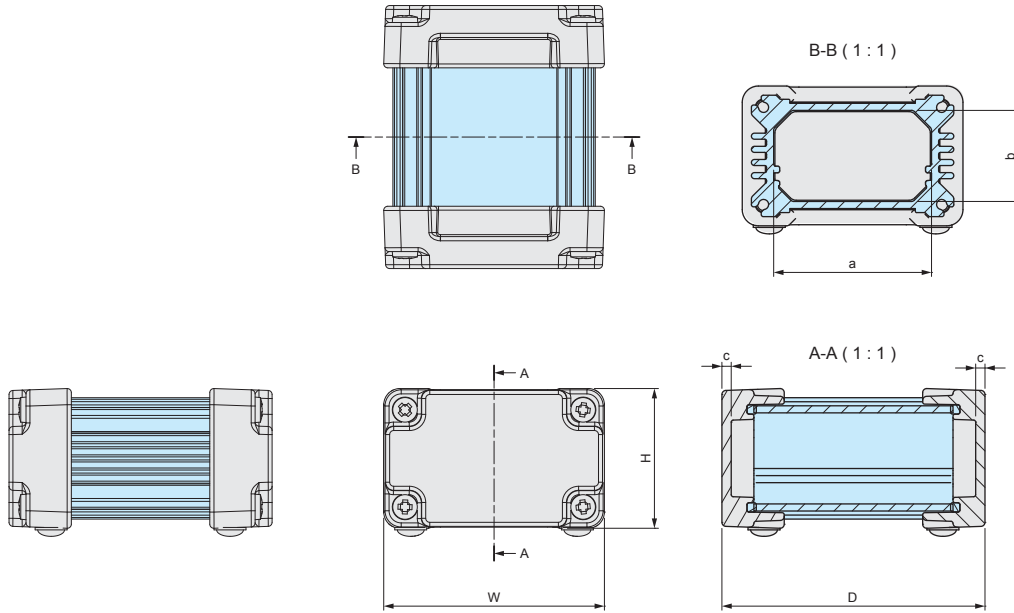

Product no. / Dimensions

■ Please suffix color code at the end of the product number.

Product no.	W	H	D	a	b	c	Weight (g)
AWN 5-4- 7□□□	54.6	34.6	65	39	22.5	2.3	118.5
AWN 5-4- 9□□□	54.6	34.6	85	39	22.5	2.3	139
AWN 5-4-11□□□	54.6	34.6	110	39	22.5	2.3	165
AWN 5-4-14□□□	54.6	34.6	135	39	22.5	2.3	191.5
AWN 7-7- 8□□□	65.8	65.8	80	47	51	2.5	272.5
AWN 7-7-11□□□	65.8	65.8	110	47	51	2.5	328
AWN 7-7-15□□□	65.8	65.8	150	47	51	2.5	402.5
AWN 7-7-20□□□	65.8	65.8	200	47	51	2.5	495
AWN 7-7-25□□□	65.8	65.8	250	47	51	2.5	588
AWN 8-5- 9□□□	80.8	45.8	90	62	31	2.5	259.5
AWN 8-5-12□□□	80.8	45.8	115	62	31	2.5	300.5
AWN 8-5-14□□□	80.8	45.8	140	62	31	2.5	342
AWN 8-5-18□□□	80.8	45.8	175	62	31	2.5	399.5
AWN 9-9-10□□□	86.3	86.3	100	66.5	66.5	3	521.5
AWN 9-9-13□□□	86.3	86.3	125	66.5	66.5	3	594.5
AWN 9-9-17□□□	86.3	86.3	170	66.5	66.5	3	725.5
AWN 9-9-22□□□	86.3	86.3	220	66.5	66.5	3	871.5
AWN 9-9-28□□□	86.3	86.3	275	66.5	66.5	3	1,032
AWN11-6-11□□□	106.3	56.3	110	86.5	36.5	3	479.5
AWN11-6-15□□□	106.3	56.3	150	86.5	36.5	3	578
AWN11-6-19□□□	106.3	56.3	190	86.5	36.5	3	676.5
AWN11-6-24□□□	106.3	56.3	240	86.5	36.5	3	800
AWN12-8-11□□□	120	71.3	105	100.2	51.5	3	590.5
AWN12-8-14□□□	120	71.3	140	100.2	51.5	3	696.5
AWN12-8-17□□□	120	71.3	179.5	100.2	51.5	3	816
AWN12-8-22□□□	120	71.3	215	100.2	51.5	3	923.5
AWN16-9-14□□□	156.3	81.3	135	136.5	61.5	3	871.5
AWN16-9-18□□□	156.3	81.3	175	136.5	61.5	3	1,018.5
AWN16-9-23□□□	156.3	81.3	225	136.5	61.5	3	1,201.5
AWN16-9-28□□□	156.3	81.3	275	136.5	61.5	3	1,385
AWN21-9-17□□□	206.3	81.3	170	186.5	61.5	3	1,261
AWN21-9-21□□□	206.3	81.3	210	186.5	61.5	3	1,431.5
AWN21-9-26□□□	206.3	81.3	260	186.5	61.5	3	1,644.5
AWN21-9-31□□□	206.3	81.3	310	186.5	61.5	3	1,857.5

Accessories (Optional parts)



Mounting plate AWC series
See page 170



Hexagon socket head screw HCS series
See page 170



Cable gland
See cable gland pages



Silicone protector AWSP series
See page 169

AWP SERIES

IP67 ALUMINIUM ENCLOSURE with SILICONE PROTECTOR



Technical Data
Protection class: IP67
Operating temperature: -40°C ~ +105°C
Recommended torque: 1.0N • m (10kgf • cm)

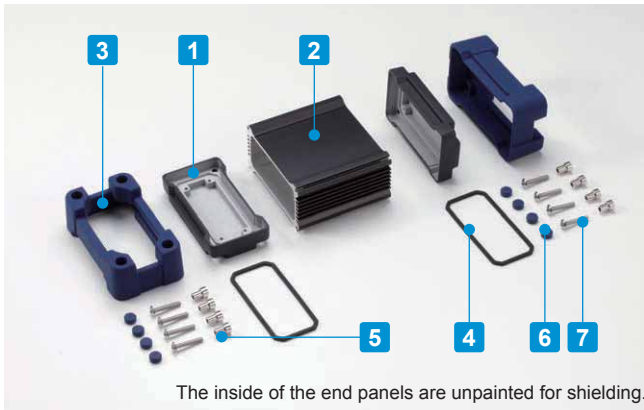

- Strong impact resistant enclosure with tough silicone boot protectors.
- Specifically designed with heat dissipation effect, EMC shielding and IP67 rating.
- PCB or chassis can be horizontally mounted by sliding into an inner-grooved body frame.
- Available in 30 sizes and 8 different color combinations. Selectable from a total of 240 different combinations.
- Suitable for measuring instruments, industrial control box, industrial camera housing, etc.

Components

No.	Part name	Pcs	Material	Color / Finish
1	End panel	2	Diecast aluminium ADC12	Silver • Black / Painted (unfinished inside)
2	Body frame	1	Extruded aluminium A6063S-T5	Silver • Black / Anodized
3	Protector	2	Silicone	Black • Gray • Navy • Yellow
4	Conductive gasket	2	Conductive silicone	Black
5	Spacer	8	Brass	Nickel plated
6	Blind cap	8	Silicone	Black • Gray • Navy • Yellow
7	Screw	8	Stainless steel	Unfinished

Color Type



Ordering Number

For example, in case of ordering AWP7-7-8 size, Black enclosure and Navy silicone protector.

Product no. : AWP7-7-8

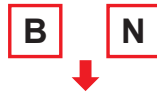

Put a color code SB, SG, SN, SY, BB, BG, BN or BY.

- ※ Thermal resistance test condition
- Ambient air cooling
- Heat-sink fins are set perpendicular to the ground with temperature at 60°C.
- Anodized aluminium extrusion
- Heat source is applied on the opposite side (inner side) of the fins.

Product no. / Dimensions

Product no.	W	H	D	※Thermal resistance rate (°C/W)	Weight (g)
AWP 7-7- 8□□	72.4(65.8)	73.6(65.8)	104 (80)	4.41	363.5
AWP 7-7-11□□	72.4(65.8)	73.6(65.8)	134(110)	3.5	419
AWP 7-7-15□□	72.4(65.8)	73.6(65.8)	174(150)	2.83	493.5
AWP 7-7-20□□	72.4(65.8)	73.6(65.8)	224(200)	2.33	586
AWP 7-7-25□□	72.4(65.8)	73.6(65.8)	274(250)	2.02	679
AWP 8-5- 9□□	87.4(80.8)	53.6(45.8)	114 (90)	5.97	353.5
AWP 8-5-12□□	87.4(80.8)	53.6(45.8)	139(115)	5.01	394.5
AWP 8-5-14□□	87.4(80.8)	53.6(45.8)	164(140)	4.37	436
AWP 8-5-18□□	87.4(80.8)	53.6(45.8)	199(175)	3.76	493.5
AWP 9-9-10□□	93.9(86.3)	95.1(86.3)	130(100)	3.1	693
AWP 9-9-13□□	93.9(86.3)	95.1(86.3)	155(125)	2.63	766
AWP 9-9-17□□	93.9(86.3)	95.1(86.3)	200(170)	2.12	897
AWP 9-9-22□□	93.9(86.3)	95.1(86.3)	250(220)	1.79	1,043
AWP 9-9-28□□	93.9(86.3)	95.1(86.3)	305(275)	1.54	1,203.5
AWP11-6-11□□	113.9(106.3)	65.1(56.3)	140(110)	4.52	652.5
AWP11-6-15□□	113.9(106.3)	65.1(56.3)	180(150)	3.62	751.5
AWP11-6-19□□	113.9(106.3)	65.1(56.3)	220(190)	3.08	850
AWP11-6-24□□	113.9(106.3)	65.1(56.3)	270(240)	2.64	973
AWP12-8-11□□	127.6(120)	80.1(71.3)	135(105)	3.6	778.5
AWP12-8-14□□	127.6(120)	80.1(71.3)	170(140)	2.93	885
AWP12-8-17□□	127.6(120)	80.1(71.3)	209.5(179.5)	2.47	1,004.5
AWP12-8-22□□	127.6(120)	80.1(71.3)	245(215)	2.18	1,112
AWP16-9-14□□	163.9(156.3)	90.1(81.3)	165(135)	2.64	1,094
AWP16-9-18□□	163.9(156.3)	90.1(81.3)	205(175)	2.2	1,240.5
AWP16-9-23□□	163.9(156.3)	90.1(81.3)	255(225)	1.86	1,424
AWP16-9-28□□	163.9(156.3)	90.1(81.3)	305(275)	1.63	1,607.5
AWP21-9-17□□	213.9(206.3)	90.1(81.3)	202(170)	2.3	1,571.5
AWP21-9-21□□	213.9(206.3)	90.1(81.3)	242(210)	1.99	1,742
AWP21-9-26□□	213.9(206.3)	90.1(81.3)	292(260)	1.72	1,955.5
AWP21-9-31□□	213.9(206.3)	90.1(81.3)	342(310)	1.54	2,168.5

■ () value = enclosure dimension.

AWP dimensions

■ DXF/DWG/PDF drawings available on our website.

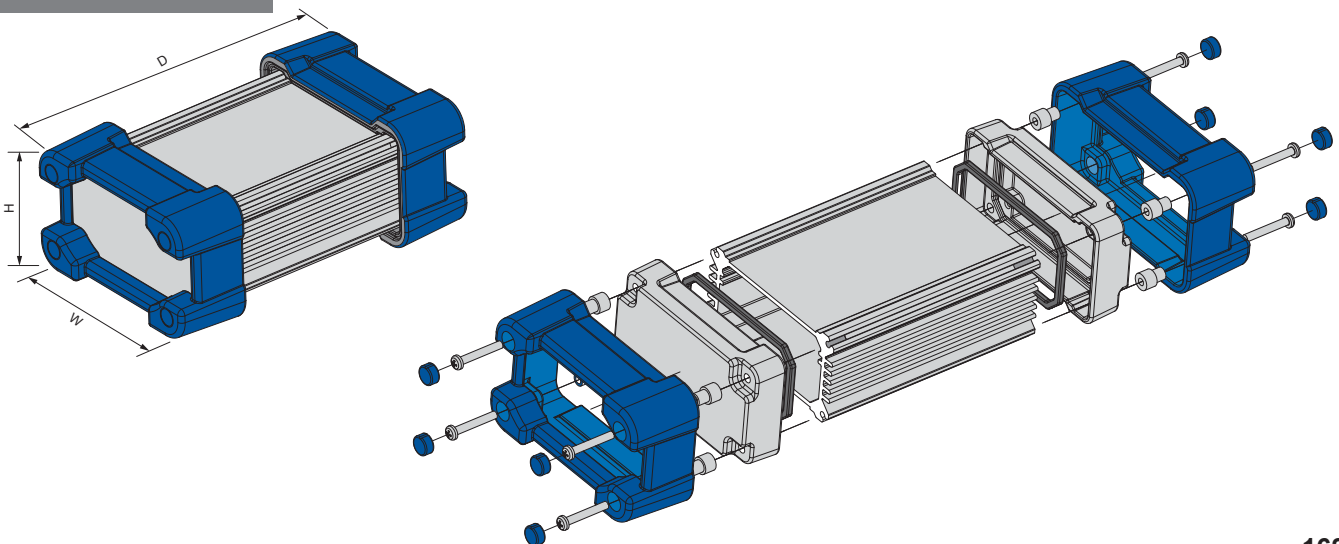

AW • AWN • AWP • AWA frame

■ Drawings below are reference examples only.
DXF/DWG/PDF drawings available on our website.

AW/AWN5-4-□
AWA5-3-□

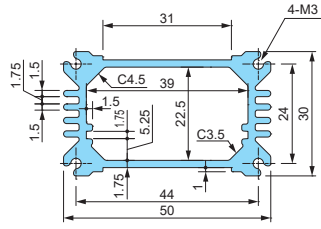

AW/AWN/AWP7-7-□
AWA6-6-□

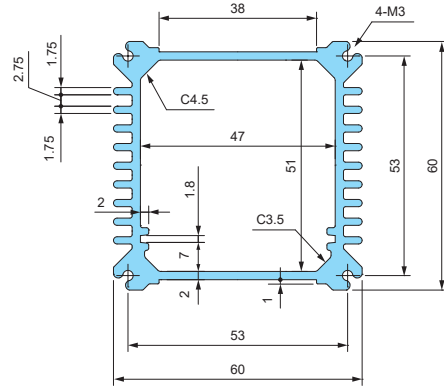

AW/AWN/AWP8-5-□
AWA8-4-□

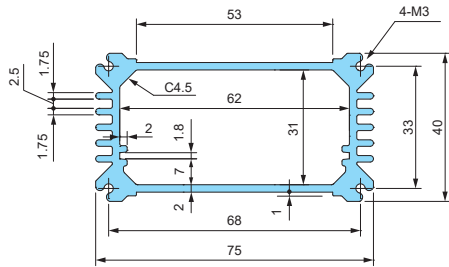

AW/AWN/AWP9-9-□
AWA8-8-□

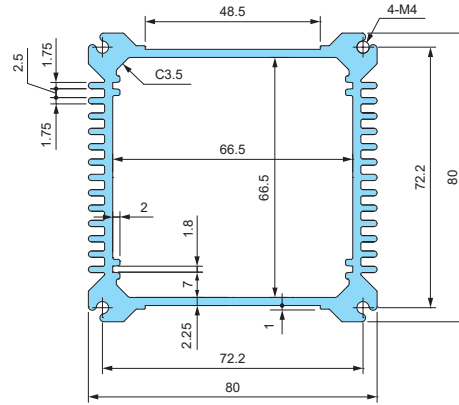

AW/AWN/AWP11-6-□
AWA10-5-□

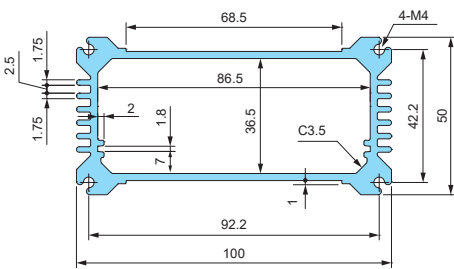

AW/AWN/AWP12-8-□
AWA12-7-□

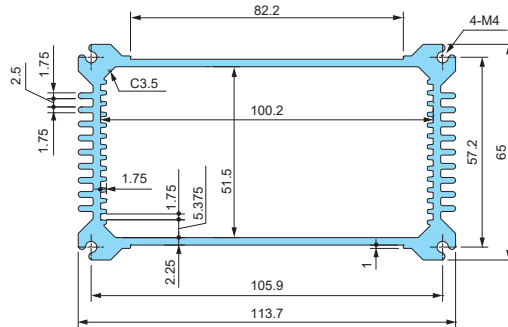

AW/AWN/AWP16-9-□
AWA15-8-□

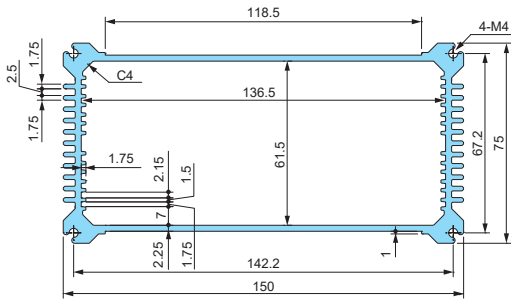

AW/AWN/AWP21-9-□
AWA20-8-□

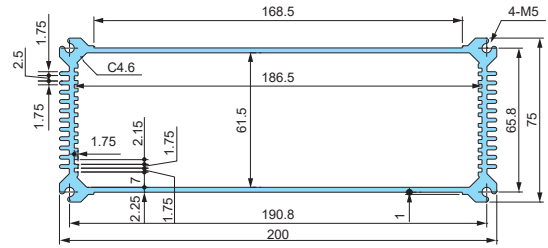

- ※ Thermal resistance test condition
- Ambient air cooling
 - Heat-sink fins are set perpendicular to the ground with temperature at 60°C.
 - Anodized aluminium extrusion
 - Heat source is applied on the opposite side (inner side) of the fins.

Product no.				Frame	※Thermal resistance rate (°C/W)
AW 5-4- 7	AWN 5-4- 7	—	AWA 5-3- 5	49.2	11.2
AW 5-4- 9	AWN 5-4- 9	—	AWA 5-3- 7	69.2	9.18
AW 5-4-11	AWN 5-4-11	—	AWA 5-3-10	94.2	7.64
AW 5-4-14	AWN 5-4-14	—	AWA 5-3-12	119.2	6.63
AW 7-7- 8	AWN 7-7- 8	AWP 7-7- 8	AWA 6-6- 7	64	4.41
AW 7-7-11	AWN 7-7-11	AWP 7-7-11	AWA 6-6-10	94	3.5
AW 7-7-15	AWN 7-7-15	AWP 7-7-15	AWA 6-6-14	134	2.83
AW 7-7-20	AWN 7-7-20	AWP 7-7-20	AWA 6-6-19	184	2.33
AW 7-7-25	AWN 7-7-25	AWP 7-7-25	AWA 6-6-24	234	2.02
AW 8-5- 9	AWN 8-5- 9	AWP 8-5- 9	AWA 8-4- 8	74	5.97
AW 8-5-12	AWN 8-5-12	AWP 8-5-12	AWA 8-4-10	99	5.01
AW 8-5-14	AWN 8-5-14	AWP 8-5-14	AWA 8-4-13	124	4.37
AW 8-5-18	AWN 8-5-18	AWP 8-5-18	AWA 8-4-16	159	3.76
AW 9-9-10	AWN 9-9-10	AWP 9-9-10	AWA 8-8- 9	81	3.1
AW 9-9-13	AWN 9-9-13	AWP 9-9-13	AWA 8-8-11	106	2.63
AW 9-9-17	AWN 9-9-17	AWP 9-9-17	AWA 8-8-16	151	2.12
AW 9-9-22	AWN 9-9-22	AWP 9-9-22	AWA 8-8-21	201	1.79
AW 9-9-28	AWN 9-9-28	AWP 9-9-28	AWA 8-8-26	256	1.54
AW11-6-11	AWN11-6-11	AWP11-6-11	AWA10-5-10	90.6	4.52
AW11-6-15	AWN11-6-15	AWP11-6-15	AWA10-5-14	130.6	3.62
AW11-6-19	AWN11-6-19	AWP11-6-19	AWA10-5-18	170.6	3.08
AW11-6-24	AWN11-6-24	AWP11-6-24	AWA10-5-23	220.6	2.64
AW12-8-11	AWN12-8-11	AWP12-8-11	AWA12-7- 9	85.6	3.6
AW12-8-14	AWN12-8-14	AWP12-8-14	AWA12-7-12	120.6	2.93
AW12-8-17	AWN12-8-17	AWP12-8-17	AWA12-7-17	160.1	2.47
AW12-8-22	AWN12-8-22	AWP12-8-22	AWA12-7-20	195.6	2.18
AW16-9-14	AWN16-9-14	AWP16-9-14	AWA15-5-12	115.6	2.64
AW16-9-18	AWN16-9-18	AWP16-9-18	AWA15-8-16	155.6	2.2
AW16-9-23	AWN16-9-23	AWP16-9-23	AWA15-8-21	205.6	1.86
AW16-9-28	AWN16-9-28	AWP16-9-28	AWA15-8-26	255.6	1.63
AW21-9-17	AWN21-9-17	AWP21-9-17	AWA20-8-15	147.8	2.3
AW21-9-21	AWN21-9-21	AWP21-9-21	AWA20-8-19	187.8	1.99
AW21-9-26	AWN21-9-26	AWP21-9-26	AWA20-8-24	237.8	1.72
AW21-9-31	AWN21-9-31	AWP21-9-31	AWA20-8-29	287.8	1.54

AWSP SERIES

SILICONE PROTECTOR

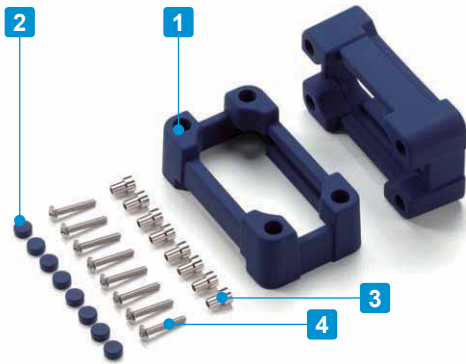

Color Type

Code	B Black	G Gray	N Navy	Y Yellow
Color				

- Silicone protector for AWN series.
- Protect switches and/or connectors on end panels from impact when dropped, etc.

AWSP dimensions

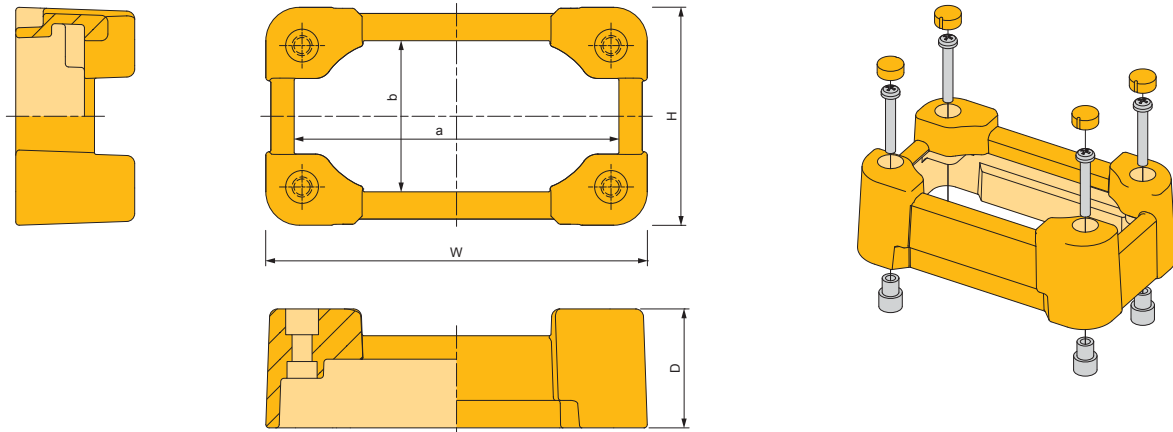

Components

No.	Part name	Pcs	Material	Color / Finish
1	Protector	2	Silicone	Black • Gray • Navy • Yellow
2	Blind cap	8	Silicone	Black • Gray • Navy • Yellow
3	Spacer	8	Brass	Nickel plated
4	Screw	8	Stainless steel	Unfinished

Product no. / Dimensions

■ Please suffix color code at the end of the product number.

Product no.	W	H	D	a	b	Screw size	Suitable enclosure	Weight (g)
AWSP 7-7□	72.4	73.6	31	58.4	56.6	M3	AWN 7-7-□	99
AWSP 8-5□	87.4	53.6	31	73.4	36.6	M3	AWN 8-5-□	100.5
AWSP 9-9□	93.9	95.1	35.5	76.9	75.1	M4	AWN 9-9-□	184.5
AWSP11-6□	113.9	65.1	35.5	96.9	45.1	M4	AWN11-6-□	186
AWSP12-8□	127.6	80.1	35.5	110.6	60.1	M4	AWN12-8-□	201
AWSP16-9□	163.9	90.1	35.5	145.9	69.1	M4	AWN16-9-□	235
AWSP21-9□	213.9	90.1	39.5	192.9	66.1	M5	AWN21-9-□	333

AWC SERIES

ALUMINIUM MOUNTING PLATE

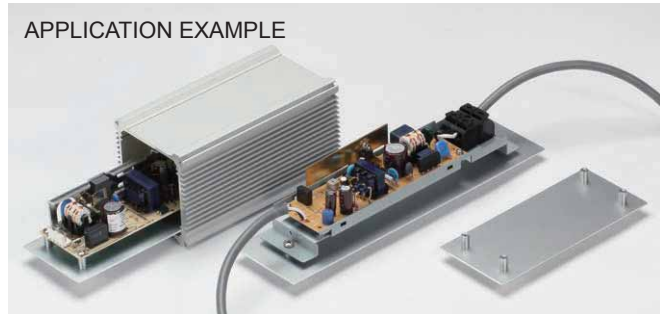
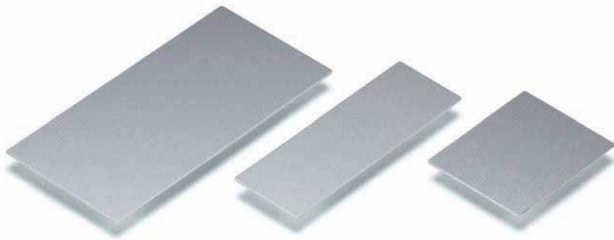

- Material: Aluminium A1050P t=1.5 / Silver anodized
- Mounting plate for AW, AWN, AWP, and AWA series enclosures.
- Utilize for mounting PCB, power supply, terminal blocks, etc.

■ DXF/DWG/PDF drawings available on our website.

Product no. / Dimensions

Product no.	W	D	Suitable enclosure
AWC 5- 7	38.9	49.2	AW • AWN 5-4-7 • AWA 5-3-5
AWC 5- 9	38.9	69.2	AW • AWN 5-4-9 • AWA 5-3-7
AWC 5-11	38.9	94.2	AW • AWN 5-4-11 • AWA 5-3-10
AWC 5-14	38.9	119.2	AW • AWN 5-4-14 • AWA 5-3-12
AWC 7- 8	47	64	AW • AWN • AWP 7-7-8 • AWA 6-6- 7
AWC 7-11	47	94	AW • AWN • AWP 7-7-11 • AWA 6-6-10
AWC 7-15	47	134	AW • AWN • AWP 7-7-15 • AWA 6-6-14
AWC 7-20	47	184	AW • AWN • AWP 7-7-20 • AWA 6-6-19
AWC 7-25	47	234	AW • AWN • AWP 7-7-25 • AWA 6-6-24
AWC 8- 9	61.8	74	AW • AWN • AWP 8-5-9 • AWA 8-4-8
AWC 8-12	61.8	99	AW • AWN • AWP 8-5-12 • AWA 8-4-10
AWC 8-14	61.8	124	AW • AWN • AWP 8-5-14 • AWA 8-4-13
AWC 8-18	61.8	159	AW • AWN • AWP 8-5-18 • AWA 8-4-16
AWC 9-10	66.5	81	AW • AWN • AWP 9-9-10 • AWA 8-8-9
AWC 9-13	66.5	106	AW • AWN • AWP 9-9-13 • AWA 8-8-11
AWC 9-17	66.5	151	AW • AWN • AWP 9-9-17 • AWA 8-8-16
AWC 9-22	66.5	201	AW • AWN • AWP 9-9-22 • AWA 8-8-21
AWC 9-28	66.5	256	AW • AWN • AWP 9-9-28 • AWA 8-8-26
AWC11-11	86.5	90.6	AW • AWN • AWP11-6-11 • AWA10-5-10
AWC11-15	86.5	130.6	AW • AWN • AWP11-6-15 • AWA10-5-14
AWC11-19	86.5	170.6	AW • AWN • AWP11-6-19 • AWA10-5-18
AWC11-24	86.5	220.6	AW • AWN • AWP11-6-24 • AWA10-5-23
AWC12-11	100.2	85.6	AW • AWN • AWP12-8-11 • AWA12-7-9
AWC12-14	100.2	120.6	AW • AWN • AWP12-8-14 • AWA12-7-12
AWC12-17	100.2	160.1	AW • AWN • AWP12-8-17 • AWA12-7-17
AWC12-22	100.2	195.6	AW • AWN • AWP12-8-22 • AWA12-7-20
AWC16-14	136.3	115.6	AW • AWN • AWP16-9-14 • AWA15-8-12
AWC16-18	136.3	155.6	AW • AWN • AWP16-9-18 • AWA15-8-16
AWC16-23	136.3	205.6	AW • AWN • AWP16-9-23 • AWA15-8-21
AWC16-28	136.3	255.6	AW • AWN • AWP16-9-28 • AWA15-8-26
AWC21-17	186.1	147.8	AW • AWN • AWP21-9-17 • AWA20-8-15
AWC21-21	186.1	187.8	AW • AWN • AWP21-9-21 • AWA20-8-19
AWC21-26	186.1	237.8	AW • AWN • AWP21-9-26 • AWA20-8-24
AWC21-31	186.1	287.8	AW • AWN • AWP21-9-31 • AWA20-8-29

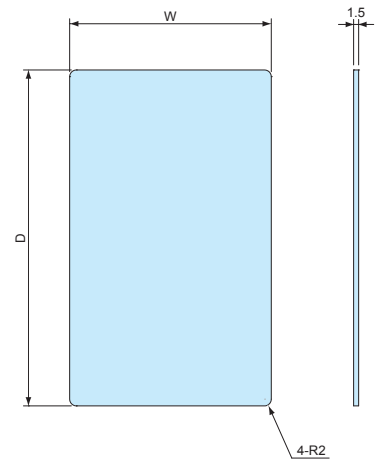

HCS SERIES

HEXAGON SOCKET HEAD SCREW

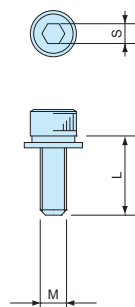

- Hexagon socket head screws for fastening the end panels of AW and AWN enclosures.
- Utilize for tamper-resistance functionality or for an elegant sleek look.

Product no. / Dimensions

Product no.	M	L	S	Material	Pack of
HCS3-12S	3	12	2.5	Stainless steel	8
HCS4-12S	4	12	3	Stainless steel	8
HCS5-12S	5	12	4	Stainless steel	8

AFS•AFM SERIES

ALUMINIUM ISOLATION FEET



- The surface treatment and finish allows the feet to exhibit a polished and luxurious feel.
- Non-slip NBR O-ring is present on the underside of the feet.
- Suitable for use in audio devices.

Available in both internal and external screw installation type.

External type / Shot blast finish (AFS series)



The external type is secured via screws from the underside / base of the feet to the enclosure. A thread hole is required for direct securing, while a circular hole is required for lock nut securing.

The shot blast finish provides a high quality surface finish look, and pairing well with various types of enclosure surfaces.

Available in both silver and black.

Internal type / Reflective finish (AFM series)



The internal type is secured via screws from the inside of the enclosure. A circular hole is required for securing into the pre-made threads in the top-side of the feet.

The reflective surface finish adds a high quality touch to the unit, allow it to have a luxurious look.

Available only in Silver.

Accessories (Optional parts)

Product no. / Dimensions

Product no.		D	H	Installation type	C	a	b	Pack of
● Silver	● Black							
AFS20- 8S	AFS20- 8B	20	8	Internal	Φ3.4	3	9	4
AFS25-10S	AFS25-10B	25	10	Internal	Φ4.5	4	12	4
AFS30-12S	AFS30-12B	30	12	Internal	Φ4.5	5	12	4
AFS35-14S	AFS35-14B	35	14	Internal	Φ4.5	5	12	4
AFS39-16S	AFS39-16B	39	16	Internal	Φ4.5	5	15	4
AFS44-18S	AFS44-18B	44	18	Internal	Φ4.5	5	20	4
AFS55-20S	AFS55-20B	55	20	Internal	Φ5.5	5	20	4
AFM15- 7S	-	15	7	External	M3	4	-	4
AFM20- 9S	-	20	9	External	M3	5	-	4
AFM25-12S	-	25	12	External	M4	7	-	4
AFM30-14S	-	30	14	External	M4	8	-	4
AFM35-16S	-	35	16	External	M4	10	-	4
AFM39-18S	-	39	18	External	M4	10	-	4
AFM44-20S	-	44	20	External	M4	10	-	4
AFM55-22S	-	55	22	External	M5	15	-	4

AFS • AFM dimensions

■ Drawings below are reference examples only.
DXF/DWG/PDF drawings available on our website.

AFS SERIES

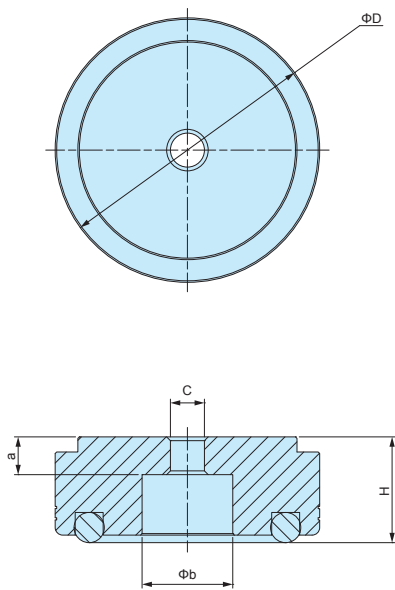

AFM SERIES

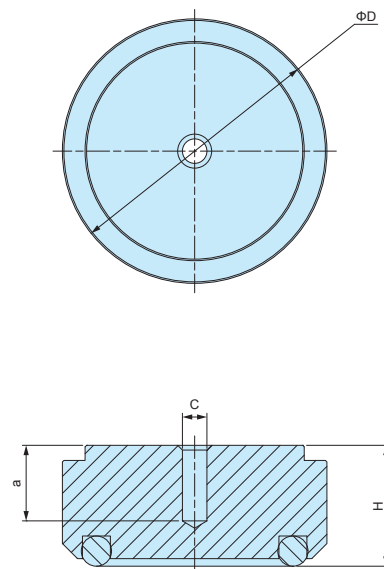

APPLICATION EXAMPLE



RS SERIES

PLATED PLASTIC FEET



- Suitable for audio equipment use.
- Elastomeric foam pad can be found at the underside of the feet.

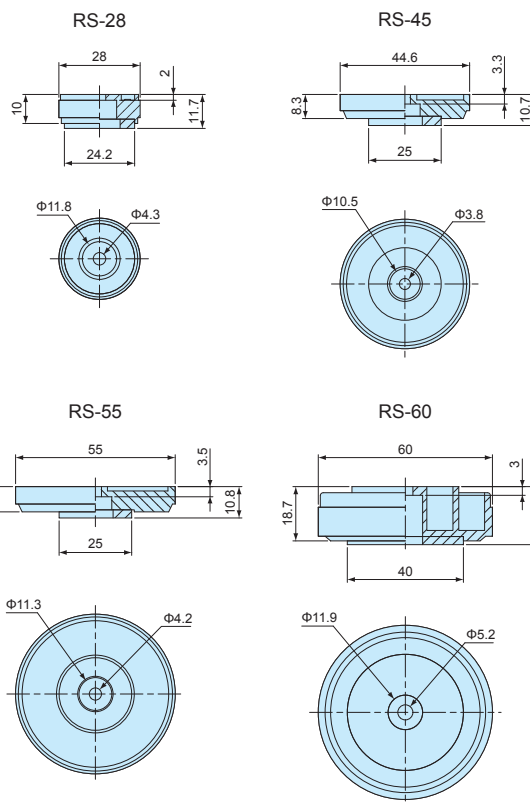

Product no. / Dimensions

Product no.		Material	Pack of
● Silver	● Gold		
RS-28S	RS-28G	ABS UL94HB / Polyester / EVA	4
RS-45S	RS-45G	ABS UL94HB / Polyester / EVA	4
RS-55S	RS-55G	ABS UL94HB / Polyester / EVA	4
RS-60S	RS-60G	ABS UL94HB / Polyester / EVA	4

TC SERIES

ALUMINIUM FEET



- Aluminium material gives it a refined and elegant look.
- Suitable for audio equipment use.
- Elastomeric foam pad can be found on the underside of the feet.

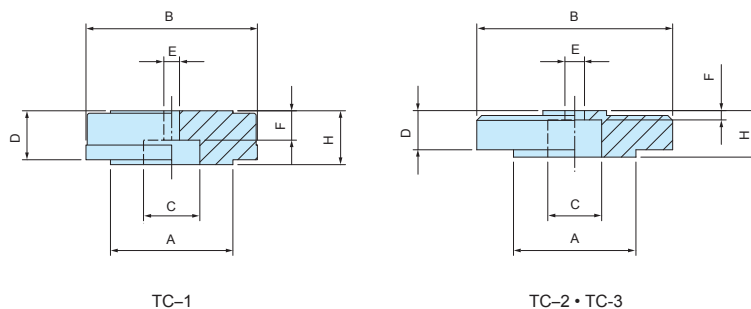

Product no. / Dimensions

Product no.		A	B	C	D	E	F	H	Material	Pack of
● Silver	● Gold									
TC-1S	TC-1G	25	35	11.5	9.7	3.4	5.6	11.5	ABS UL94HB / Aluminium / EVA	4
TC-2S	TC-2G	25	40	11	10.2	4.1	2.1	12	ABS UL94HB / Aluminium / EVA	4
TC-3S	TC-3G	25	45	11.7	12	4.2	7.5	15	ABS UL94HB / Aluminium / EVA	4

CNC MACHINING

CNC milling is a form of computer controlled machining. Similar in operation to drilling and cutting, it is able to create various hole styles and shapes by using a rotating cutting tool to bore into the object.



Extruded aluminium

- Mainly used for plastic, aluminium die-cast, and aluminium extrusion material types.
- Able to perform milling for various shapes and sizes.
- Recommended for small quantity customization.



Aluminium sheet



Diecast aluminium



Plastic enclosure



Large plastic box

ENGRAVING

By having the drill-head slightly milling the surface, the engraving of fine text or complex designs is able to be performed on a variety of surfaces, be it flat, curved, and so on. Suitable for small batch print, and/or simple lettering. Font shall be similar to VAG Rounded font type.

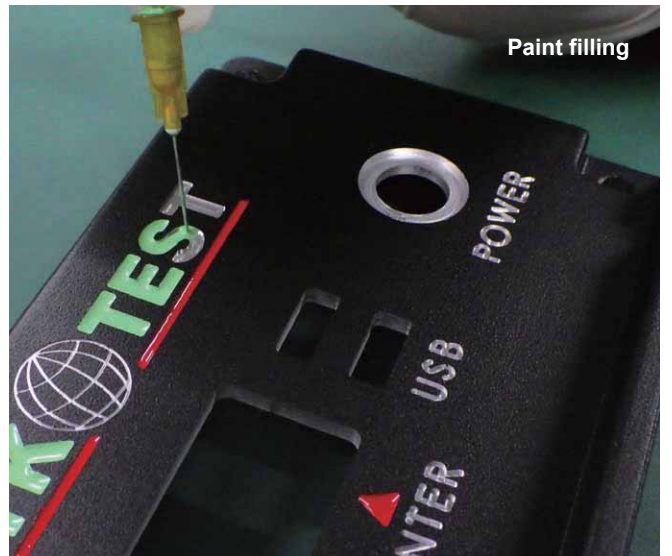
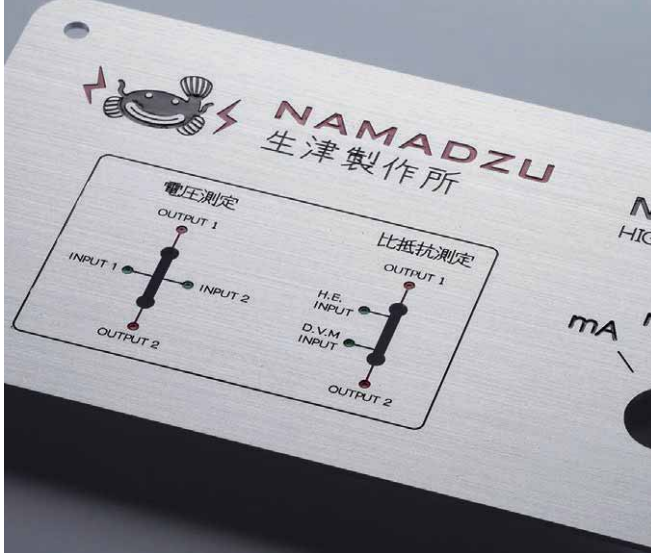

LASER CUTTING

Laser cutting utilizes a laser to perform cutting on an object, allowing various types and shapes of holes to be cut.

New fiber laser machine allows the processing of aluminium sheets with both high precision and speed. Processing of Pure Aluminium 1050 is also possible with minimal burr as compared to conventional CO² laser machines, which causes excessive burring.



PUNCHING PRESS

What is punching press? It is a type of machine press used to cut holes in material via the use of various sized die sets.

Punching press allows the realization of high cost performance due to its high speed automated turret punching process, which significantly reduces machining lead-time.

Due to its ability to create designated sized holes by means of rapid multiple hole punches, this enables it to punch holes of various sizes and types quickly and efficiently.

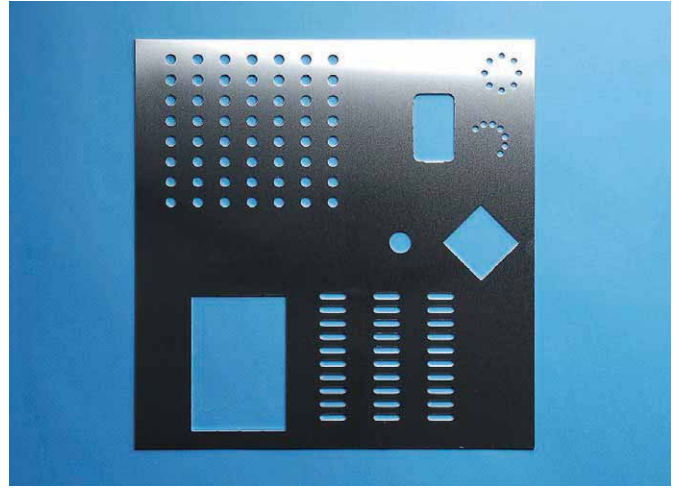
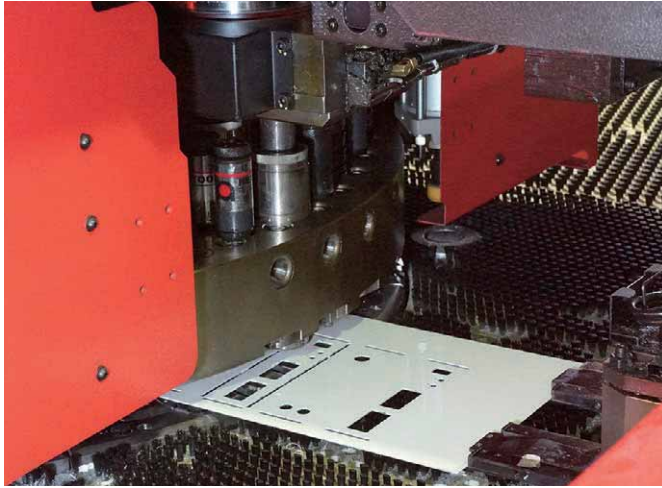

Circular hole

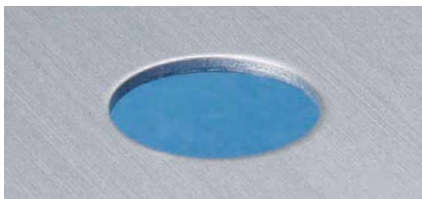

Circular holes as small as 1.0mm in diameter can be punched.

Nibbling press (rectangle)

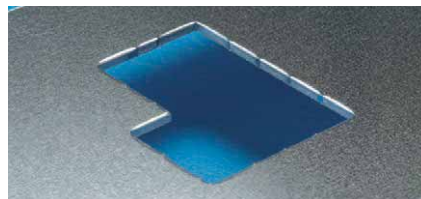

Complex or large rectangular shapes can be punched out with multiple presses.

Nibbling press (round)

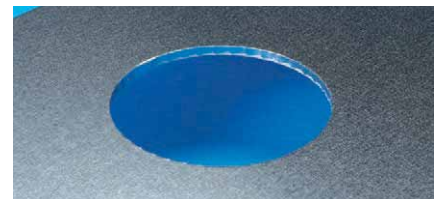

Punching of large circular holes with multiple smaller die strokes.

Common connector shapes

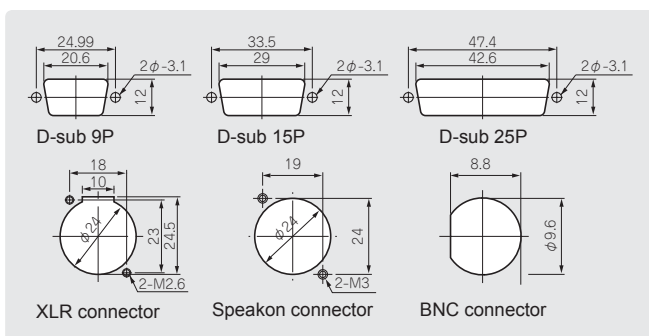

Unique shapes

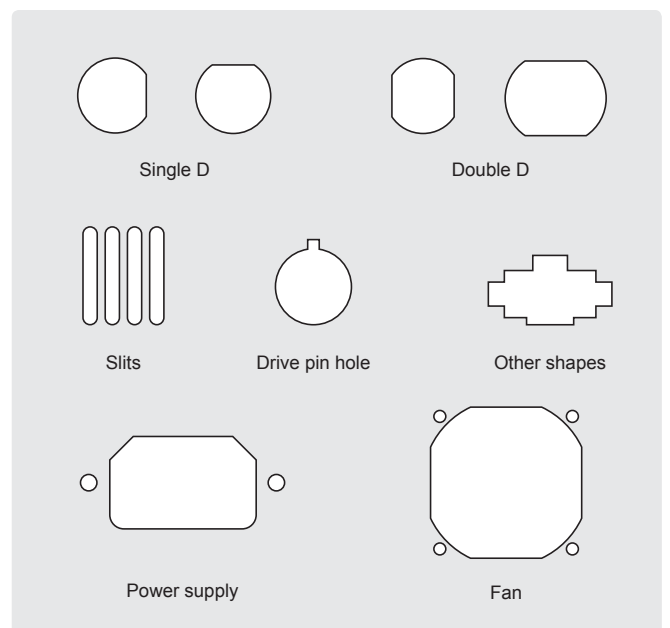

Burring punch



Increasing surface area on a thin metallic sheet for screw threads to bore into.

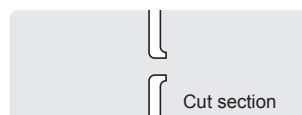

INKJET PRINTING



Full color digitally designed image can be printed in 1 run.
No cost difference regardless of the number of colors used.

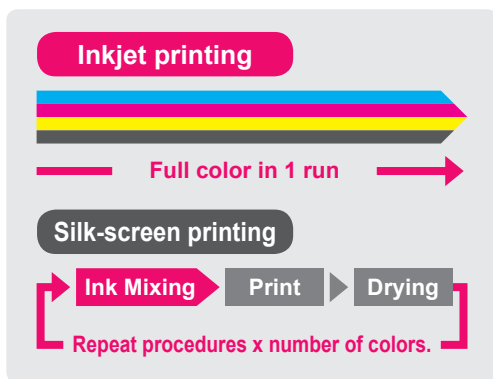

Low printing cost
Full color print possible in small quantities

Inkjet printing 1 run only for full color print

Printing cost Full color

Silk-screen printing Printing cost x number of colors

Printing cost Color 1	Printing cost Color 2	Printing cost Color 3	Printing cost Color 4
-----------------------	-----------------------	-----------------------	-----------------------

High quality printing of photo image and color gradation.

Print photo images in maximum 1,800 x 1,800 dpi quality.

Pictures, logos and unique designs with color gradation can be recreated in a high quality print.



Maximum printable enclosure size



Printable on surfaces with height differential

Printing is possible on recessed, sloped and rounded sections.

Gap difference is less than 2.0mm.

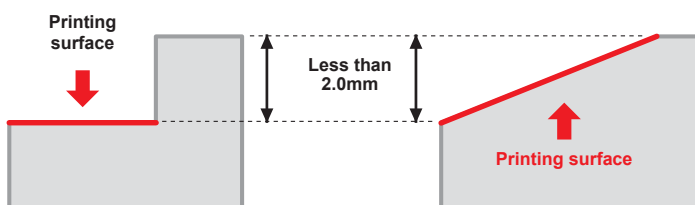

*Not suitable if height difference is more than 2.0mm.



Printed example

