

TAKACHI

SHOW IT THROUGH SKELETON CASE

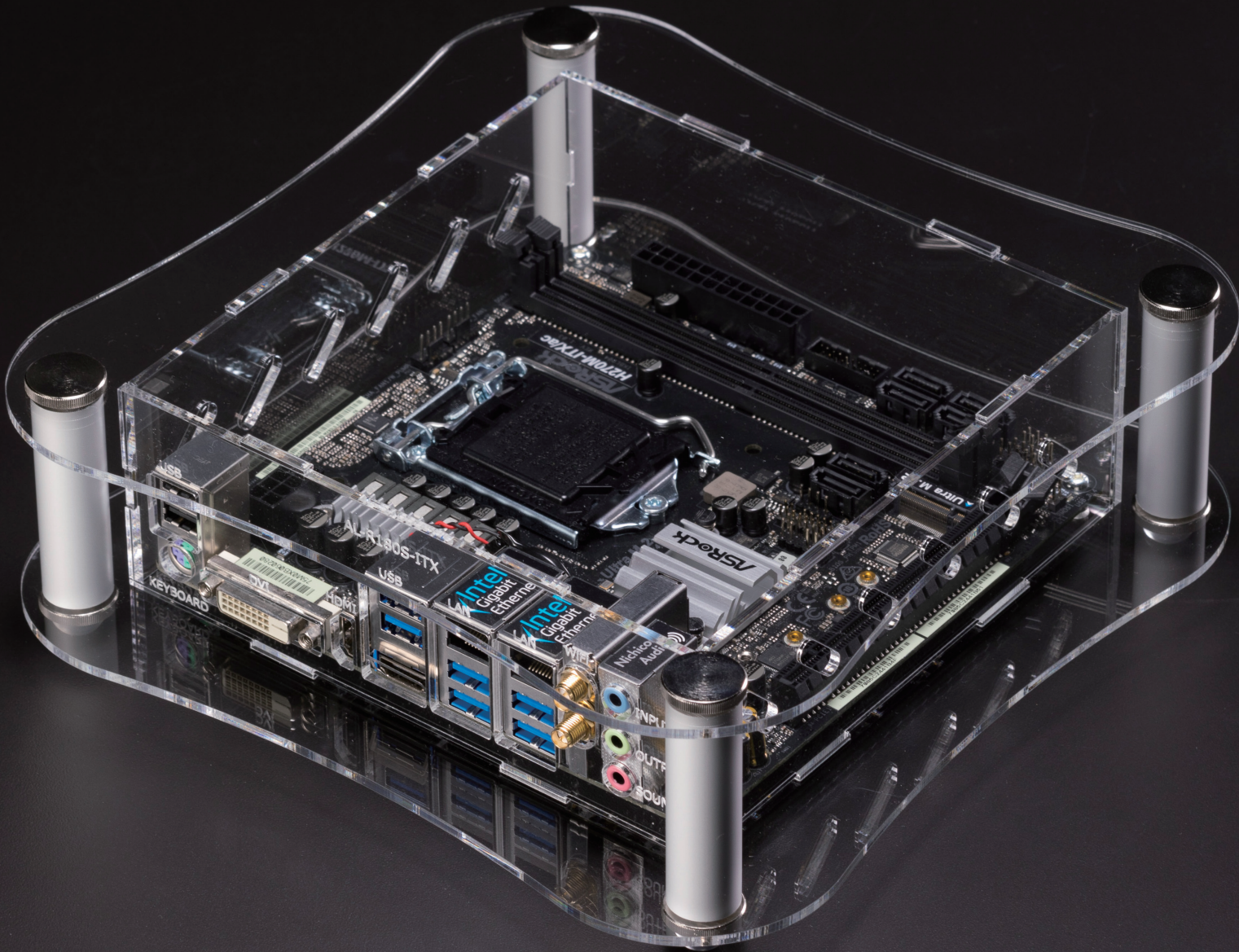

CASE BOX RACK & CUSTOM
TAKACHI ELECTRONICS ENCLOSURE CO., LTD.

Show inside for visual appeal with our transparent case.

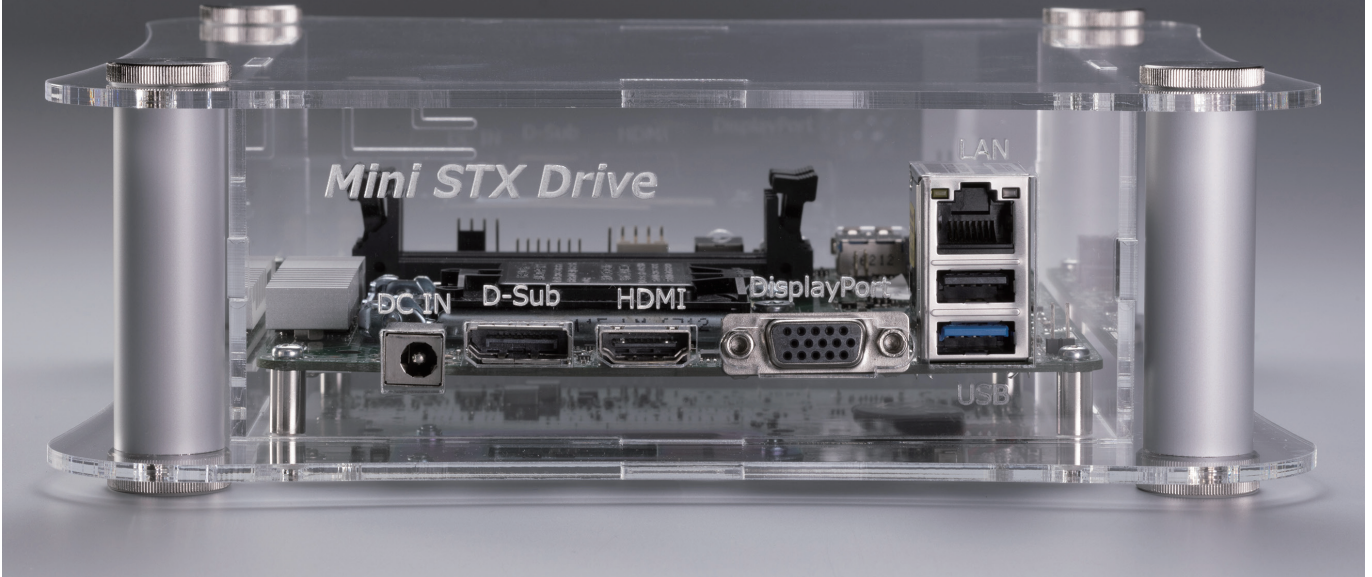

EMBEDDED COMPUTER

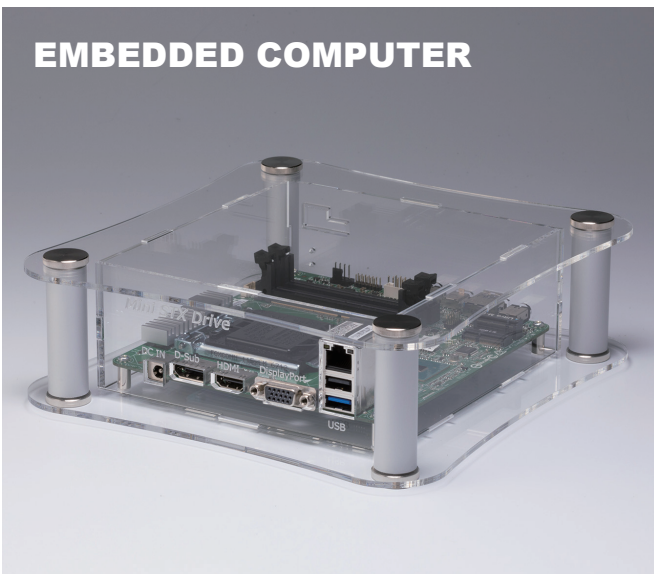

RASPBERRY PI CASE

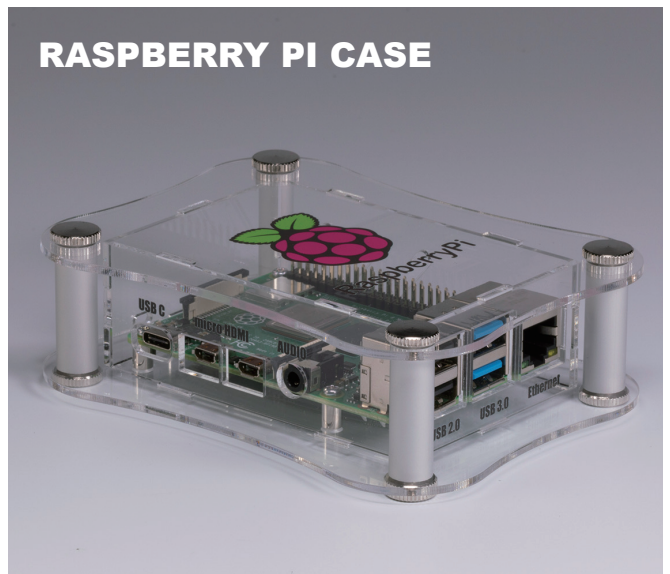

DISPLAY CASE



THERMOSTAT

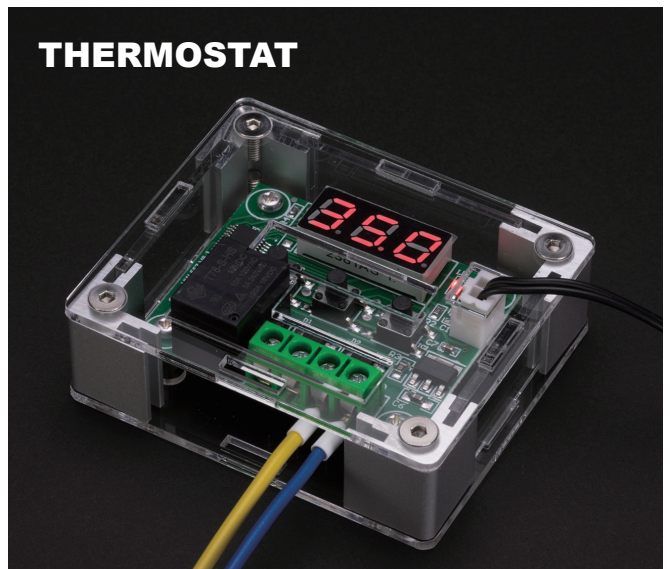

CUSTOMIZATION POSSIBILITIES

Inkjet Printing • Engraving

Print your logo, letters via inkjet printing with low initial cost from just 1 piece.
Engraving is also possible!

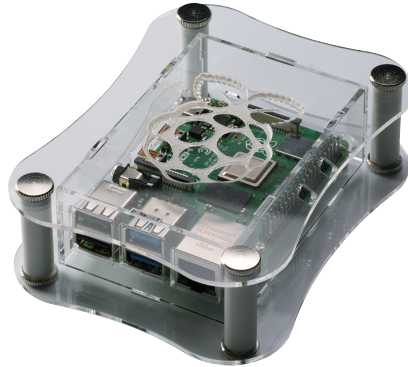

Developed Idea by using acrylic panels

Aluminium panels can be exchanged for an acrylic panel for display of internal components. Perfect for use as showcase models or product demonstrations. (Example: FC series)

Used as a visually appealing decorative front panel placing on a standard aluminium panel. (Example: AWA series)



COLOR VARIATION

Available in different color types, as well as smoked / tinted shades.

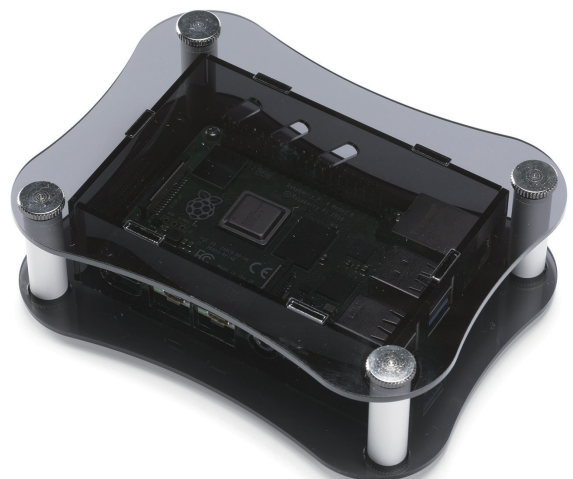
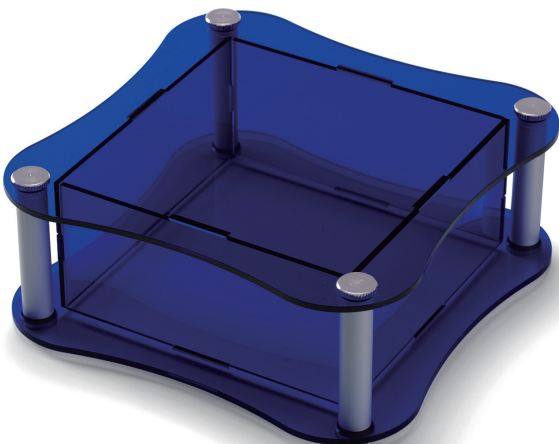

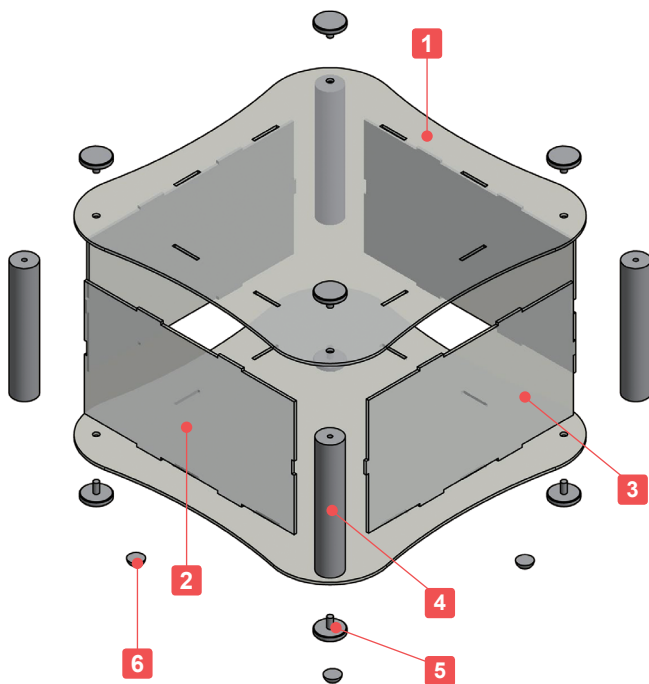

- Curved transparent acrylic case with corner support columns.
- 5 different sizes are available.
- Usable as a display enclosure for a unique and luxurious outlook.
- SKL11-5-17 and 11-8-17 models are compatible with the Euro Board.
- SKL18-7-18 and 18-10-18 models are compatible with the Mini ITX board.
- Possible to be used in a flat layout, or a standing layout.
- Knurled thumb screws for easy hand assembly.

- Custom sized case are available. See SKLF series catalog pages.

※Ethanol or other alcoholic solvents may cause the acrylic panel to crack. Use a neutral cleaner or specialized acrylic cleaning solvent for cleaning.

Components

No.	Part name	Pcs	Material	Color / Finish
1	Top · Bottom cover	1 each	Acrylic	Transparent
2	W panel	2	Acrylic	Transparent
3	D panel	2	Acrylic	Transparent
4	Pillar	4	Extruded aluminium A6063S-T5	Silver anodized
5	Knurled thumb screw	8	Brass	Nickel plated
6	Rubber feet	4	Polyurethane	Transparent

SKL dimensions

■ Drawings below are reference examples only.
DXF/DWG/PDF drawings available on our website.

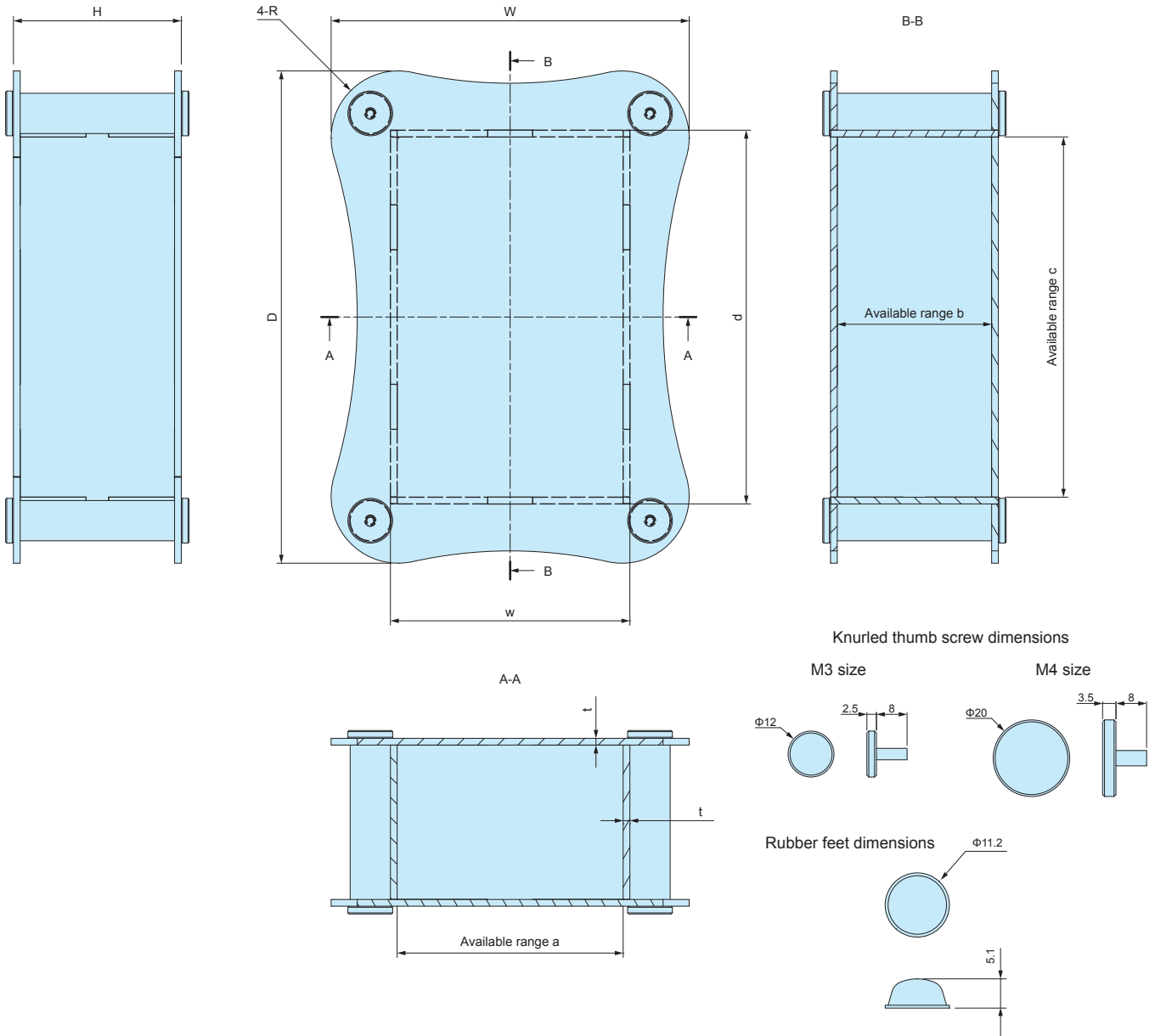

Product no. / Dimensions

Product no.	External dimensions			Case dimensions		Available range			R	t	Screw size	Weight (g)
	W	H	D	w	d	a	b	c				
SKL10- 5-10	141	51	141	105	105	101	47	101	25	2	M3	191.5
SKL11- 5-17	165	47	225	107	167	101	41	161	25	3	M4	507
SKL11- 8-17	165	77	225	107	167	101	71	161	25	3	M4	643
SKL18- 7-18	239	67	239	177	177	171	61	171	40	3	M4	762
SKL18-10-18	239	102	239	177	177	171	96	171	40	3	M4	940.5

■ Similar aluminium type design, as well as custom sizes are also available.



Custom sized skeleton case SKLF series
See page SKLF-1 ~ SKLF-4

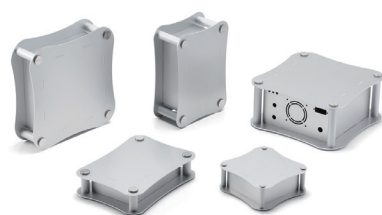

Arc design aluminium case ALR series
See page ALR-1 ~ ALR-4

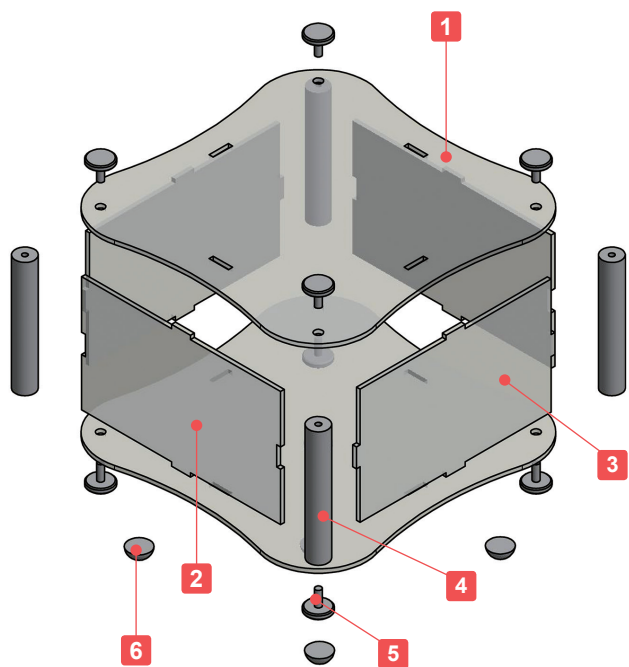

- Adjustable sizes available in 1mm intervals, with W and D dimensions from 50 ~ 500mm, and H dimensions from 30 ~ 500mm.
- Rubber feet can be provided if required in S (Φ11.2mm) or L (Φ15.7mm) sizes.
- Knurled thumb screws for easy hand assembly.

※Ethanol or other alcoholic solvents may cause the acrylic panel to crack. Use a neutral cleaner or specialized acrylic cleaning solvent for cleaning.

■ **Caution**

- On larger sized cases, the top cover may come loose if the middle part is held without support.



Components

No.	Part name	Pcs	Material	Color / Finish
1	Top · Bottom cover	1 each	Acrylic	Transparent
2	W panel	2	Acrylic	Transparent
3	D panel	2	Acrylic	Transparent
4	Pillar	4	Extruded aluminium A6063S-T5	Silver anodized
5	Knurled thumb screw	8	Brass	Nickel plated
6	Rubber feet	0 or 5	Polyurethane	Transparent

SKLF Type Chart

Refer to the below chart for S10 or S18 type selection by W & D dimensions.

[S10] type : t = 2.0mm · M3 screw · Φ10.0 pillar

[S18] type : t = 3.0mm · M4 screw · Φ18.0 pillar

W	H	D									
		50~100	101~150	151~200	201~250	251~300	301~350	351~400	401~450	451~500	
50~100	30~100										
	101~200										
	201~300										
	301~400										
	401~500										
101~150	30~100	[S10] type									
	101~200										
	201~300										
	301~400										
	401~500										
151~200	30~100										
	101~200										
	201~300										
	301~400										
	401~500										
201~250	30~100										
	101~200										
	201~300										
	301~400										
	401~500										
251~300	30~100										
	101~200										
	201~300										
	301~400										
	401~500										
301~350	30~100										
	101~200										
	201~300										
	301~400										
	401~500										
351~400	30~100										
	101~200										
	201~300										
	301~400										
	401~500										
401~450	30~100										
	101~200										
	201~300										
	301~400										
	401~500										
451~500	30~100										
	101~200										
	201~300										
	301~400										
	401~500										

SKLF dimensions

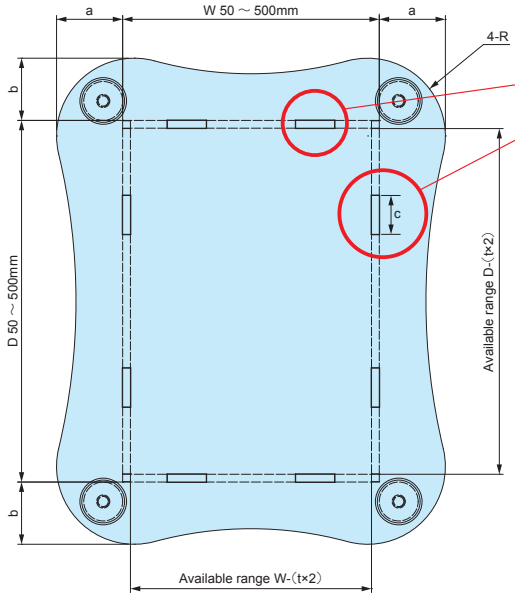

Number of joints vary by specified W / D dimensions. Refer to the below chart for more information.

W dimension	Joints (one side)	D dimension	Joints (one side)
50~150	1	50~150	1
151~200	2	151~200	2
201~300	3	201~300	3
301~400	4	301~400	4
401~500	5	401~500	5

Joint c dimension = 20.0mm

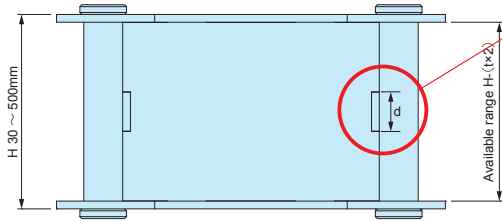

Number of joints vary by specified H dimensions. Refer to the below chart for more information.

H dimension	Joint d dimension	Joints (one side)
30~100	10mm	1
101~200	20mm	1
201~300	20mm	2
301~400	20mm	3
401~500	20mm	4

D dimension	50~100			101~150			151~200			201~250			251~300		
	a	b	R	a	b	R	a	b	R	a	b	R	a	b	R
50~100	17	17	15	17	17	15	29	28	15	29	28	15	30	28	15
101~150	17	17	15	18	18	25	29	29	25	30	29	25	30	29	25
151~200	28	29	15	29	29	25	31	31	40	31	31	40	32	31	40
201~250	28	29	15	29	30	25	31	31	40	33	33	50	33	33	50
251~300	28	30	15	29	30	25	31	32	40	33	33	50	35	35	60
301~350	35	37	15	36	38	25	38	39	40	40	41	50	42	42	60
351~400	35	38	15	36	38	25	38	40	40	40	41	50	42	43	60
401~450	35	38	15	36	39	25	38	40	40	40	42	50	42	43	60
451~500	35	39	15	36	39	25	38	41	40	40	42	50	42	44	60

D dimension	301~350			351~400			401~450			451~500		
	a	b	R	a	b	R	a	b	R	a	b	R
50~100	37	35	15	38	35	15	38	35	15	39	35	15
101~150	38	36	25	38	36	25	39	36	25	39	36	25
151~200	39	38	40	40	38	40	40	38	40	41	38	40
201~250	41	40	50	41	40	50	42	40	50	42	40	50
251~300	42	42	60	43	42	60	43	42	60	44	42	60
301~350	44	44	70	44	44	70	45	44	70	45	44	70
351~400	44	44	70	46	46	80	46	46	80	47	46	80
401~450	44	45	70	46	46	80	48	48	90	48	48	90
451~500	44	45	70	46	47	80	48	48	90	50	50	100