

**SG SERIES**

**RUBBER MEMBRANE GROMMET**

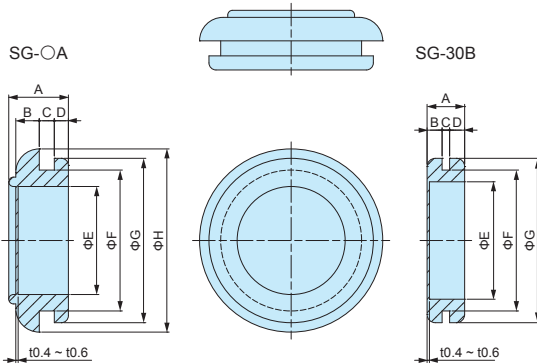

■ DXF/DWG/PDF drawings available on our website.



**Technical Data**

Operating temperature: -30°C ~ +100°C

**Components**

Material	Hardness	Color
EPDM	55°±5°	Black

■ Membrane thickness = 0.4 ~ 0.6mm

**Product no. / Dimensions**

Product no.	A	B	C	D	E	F	G	H	Pack of
SG- 9A	8.5	3.5	2.3	2	4.5	9	13	16	10
SG-12A	6.3	2.5	1.6	1.5	7	12	16	19	10
SG-14A	8	2.7	2.3	2	9	14	18	21	10
SG-16A	8.1	3.5	1.6	2	11	16	20	23	10
SG-18A	8.8	3.5	2.3	2	13	18	22	25	10
SG-20A	9.1	4	1.6	2.5	15	20	24	27	10
SG-22A	9.8	4	2.3	2.5	17	22	26	29	10
SG-24A	11.3	5	2.3	3	19	24	28	31	10
SG-26A	12.2	5	3.2	3	19	26	31	35	10
SG-28A	11.8	5	2.3	3	21	28	33	37	10
SG-30A	12.7	5	3.2	3	23	30	35	39	10
SG-30B	8	3.2	1.6	3.2	25	30	35	—	10
SG-32A	11.8	5	2.3	3	25	32	37	41	10
SG-34A	12.7	5	3.2	3	27	34	39	43	10
SG-36A	13.8	6	2.3	4	28	36	42	45	10
SG-38A	14.7	6	3.2	4	30	38	44	48	10
SG-42A	14.7	6	3.2	4	34	42	48	52	10

**NG SERIES**

**RUBBER GROMMET**



■ DXF/DWG/PDF drawings available on our website.

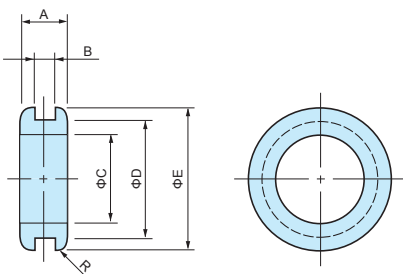

**Technical Data**

Operating temperature: -30°C ~ +100°C

**Components**

Material	Hardness	Color
EPDM	50° ~ 55°	Black

**Product no. / Dimensions**

Product no.	A	B	C	D	E	R	Pack of
NG-79-1	3.7	1.2	3.5	6	9	0.6	10
NG-79-A1	4	1	5	8	11	0.6	10
NG-79-A	4.5	1.5	5	8	11	0.6	10
NG-79-A2	5	2	5	8	11	0.6	10
NG-79-B	6	3	5	8	11	0.6	10
NG-79-C	4.5	1.5	7	10	13	0.6	10
NG-79-D	6	3	7	10	13	0.6	10
NG-79-E	4.5	1.5	9	12	15	0.6	10
NG-79-F	6	3	9	12	15	0.6	10
NG-79-G	5.5	1.5	11	15	19	1	10
NG-79-H	7	3	11	15	19	1	10
NG-79-J	5.5	1.5	13	17	21	1	10
NG-79-K	7	3	13	17	21	1	10
NG-79-L	5.5	1.5	15	19	23	1	10
NG-79-M	7	3	15	19	23	1	10
NG-79-N	6.5	1.5	20	25	30	1.2	10
NG-79-O	8	3	20	25	30	1.2	10
NG-79-P	6.5	1.5	25	30	35	1.2	10
NG-79-Q	8	3	25	30	35	1.2	10
NG-79-R	7.5	1.5	30	36	42	1.2	10
NG-79-S	9	3	30	36	42	1.2	10
NG-74	4	1	3	5	7	1	10
NG-742	5	2	3	5	7	1	10