

MD SERIES

EXTERNAL BATTERY BOX



- External battery box.
 - Simple construction for easy opening and closing.
 - MD-006P box can be used with battery holder (see page SN • MP • BH211-1 ~ SN • MP • BH211-4).
 - ⊕ ⊖ markings are available to avoid incorrect placement of the battery.
 - Battery dimensions may vary depending on country and brand.
- Use optional battery cushion sponge to preventing rattling.

Technical Data

Operating temperature: -10°C ~ +60°C

Accessories (Optional parts)

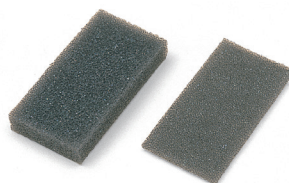

Battery cushion sponge SCM series
See page BH9V-2 • SCM-1

MD dimensions

MD-006P

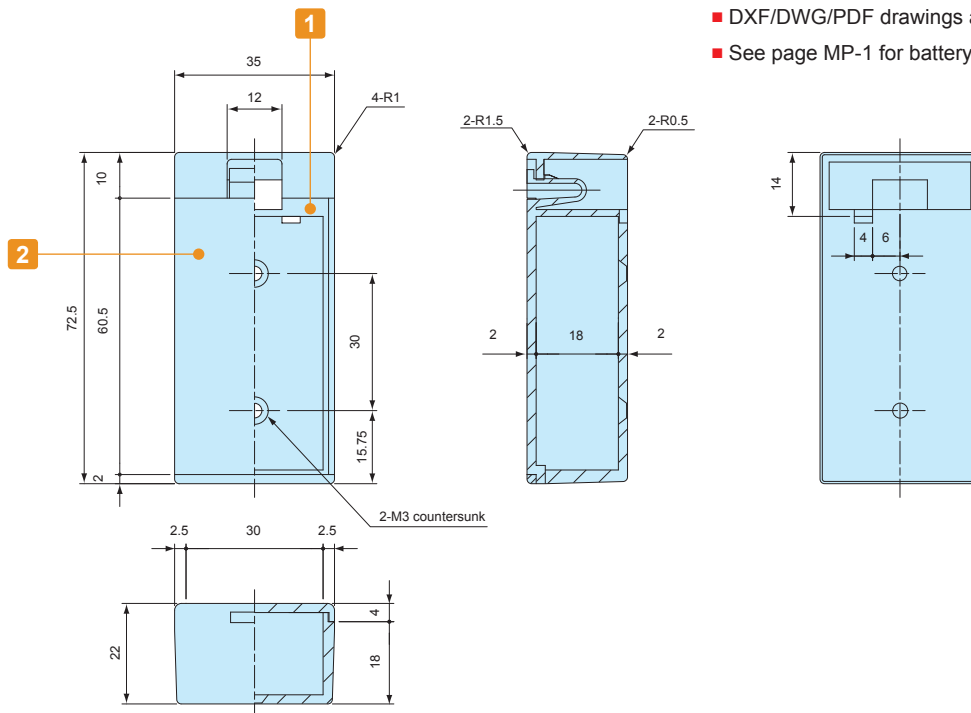

- DXF/DWG/PDF drawings available on our website.
- See page MP-1 for battery snap information.

Components (MD-006P)

No.	Part name	Material	Color
1	Box	ABS UL94V-0	Black • Light gray
2	Cover	ABS UL94V-0	Black • Light gray
-	Battery snap (MP-ILN)	ABS UL94HB • PVC + Copper wire (UL1007 AWG26)	Black • Red/Black

Components (MD-2 • MD-4)

No.	Part name	Material	Color
1	Box	ABS UL94V-0	Black • Light gray
2	Cover	ABS UL94V-0	Black • Light gray
3	Battery contact (IT-3 models)	Brass t = 0.3 • Steel wire Φ0.6	Nickel plated

MD-2

DXF/DWG/PDF drawings available on our website.

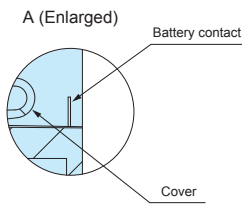
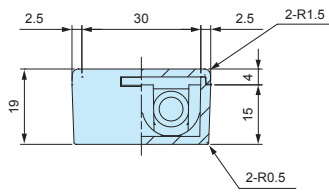
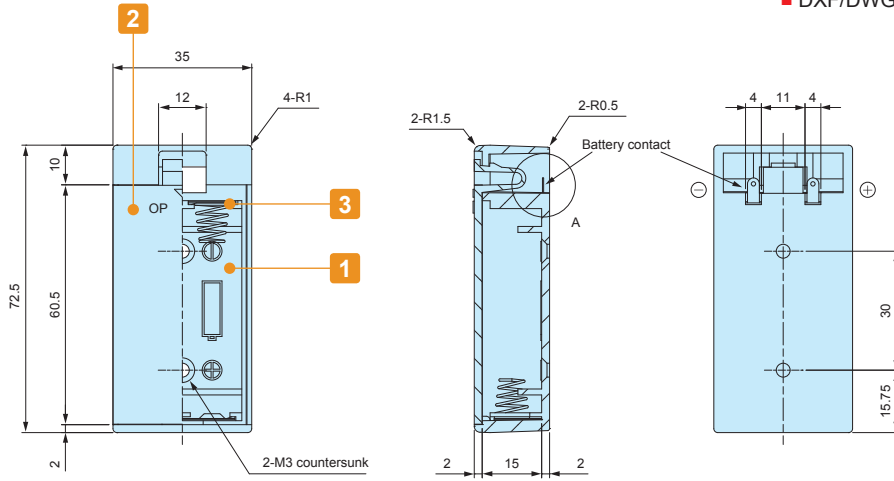

Caution

Remove cover when soldering to prevent it from being deformed by heat.

MD-4

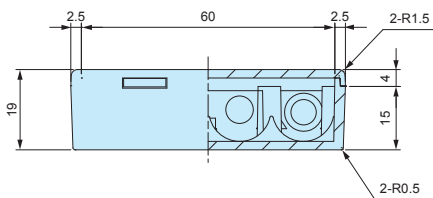
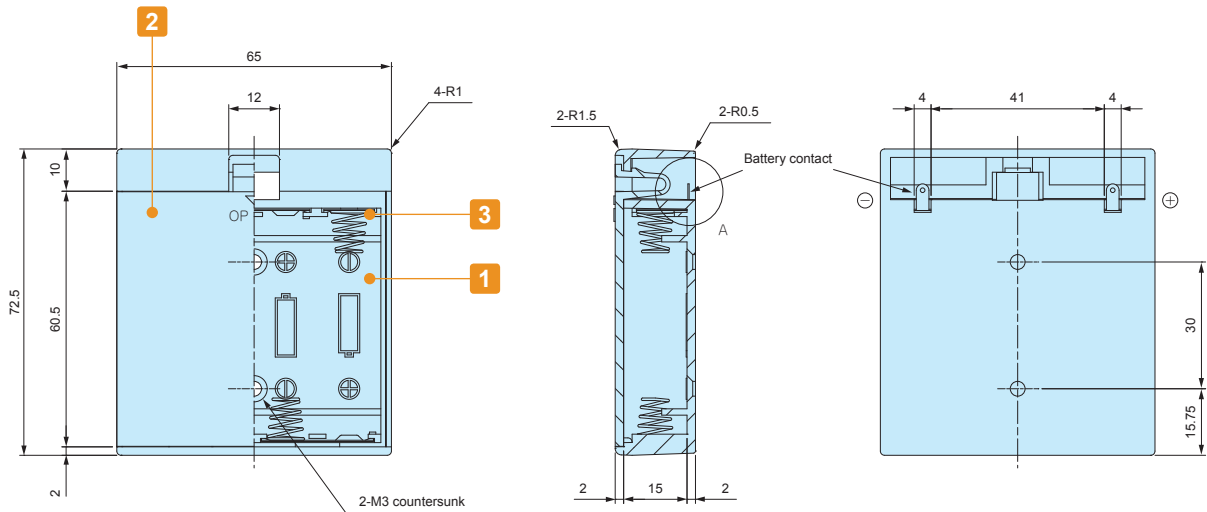

Product no. / Feature

Product no.		Matching battery	Weight (g)	Suitable cushion sponge
● Black	● Light gray			
MD-006PB	MD-006PG	9V x 1	24	SCM-1
MD-2B	MD-2G	AA x 2	22	SCM-1
MD-4B	MD-4G	AA x 4	38	SCM-1

BH-9V-2

9V BATTERY HOLDER

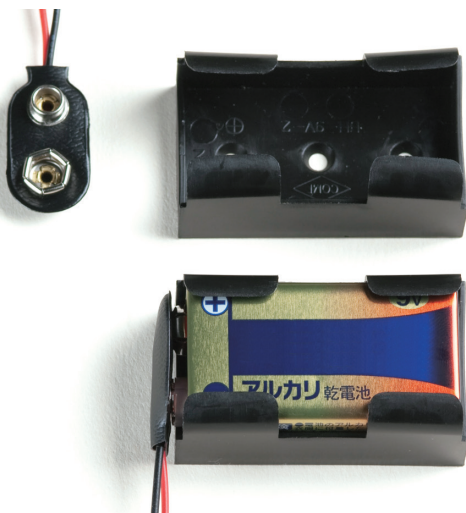

■ DXF/DWG/PDF drawings available on our website.

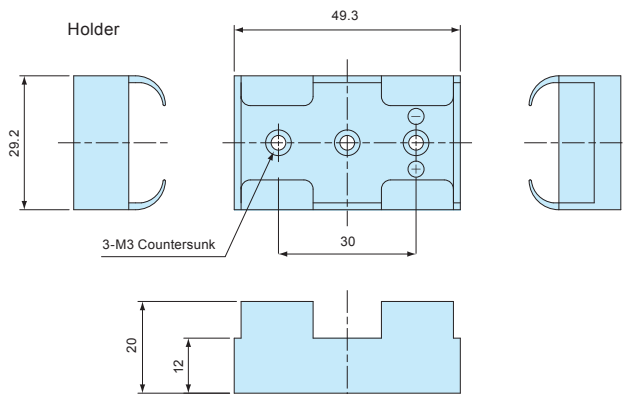

- 9V battery holder
- Battery snap comes with holder.

Technical Data
Operating temperature: -10°C ~ +60°C

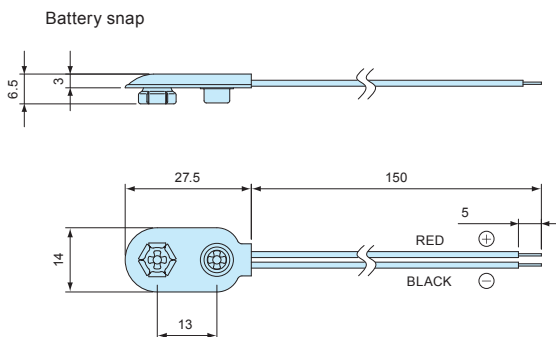

Components

Holder material	Holder color	Lead wire	Contact material	Battery snap cover	Contact surface finish
PP	Black	UL1007 AWG26 L=150	Brass	PVC	Nickel plated

Product no. / Feature

Product no.	Battery	Battery snap (included)	Weight (g)	Pack of
BH-9V-2	9V x 1	MP-1SN	6.8	1

SCM SERIES

BATTERY CUSHION SPONGE

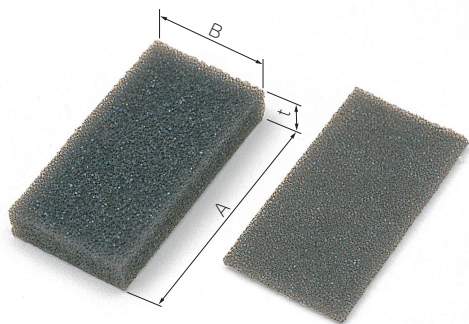

- Flame resistant moltoprene sponge with adhesive on the back side.
- Use to prevent battery from rattling inside the holder.

■ Material : Moltoprene (UL94HF-1)

Suitable battery holder

Product no.	Suitable battery holder
SCM-1	MD-2, MD-4, MD-006P, LD-2, LD-3, LD-4, LDN-2, LDN-3, LDN-4
SCM-2	LD-006P, LDN-006P
SCM-3	MD-006P

Product no. / Dimensions

Product no.	A	B	t	Pack of
SCM-1	50	25	2	10
SCM-2	50	25	4	10
SCM-3	50	25	7.5	10