

Technical Data
Operating temperature: -10°C ~ +60°C

- Snap-in battery box for enclosures.
- Suitable to be installed into enclosures with a panel thickness of 1.0mm to 3.0mm.
- Screw mounting is also possible with built-in M3 countersunk holes.
- ⊕ ⊖ markings are available to avoid incorrect placement of the battery.
- LD-006P box can be used with battery holder (see page SN • MP • BH211-1 ~ SN • MP • BH211-4).
- Battery dimensions may vary depending on country and brand.  
Use optional battery cushion sponge to preventing rattling.

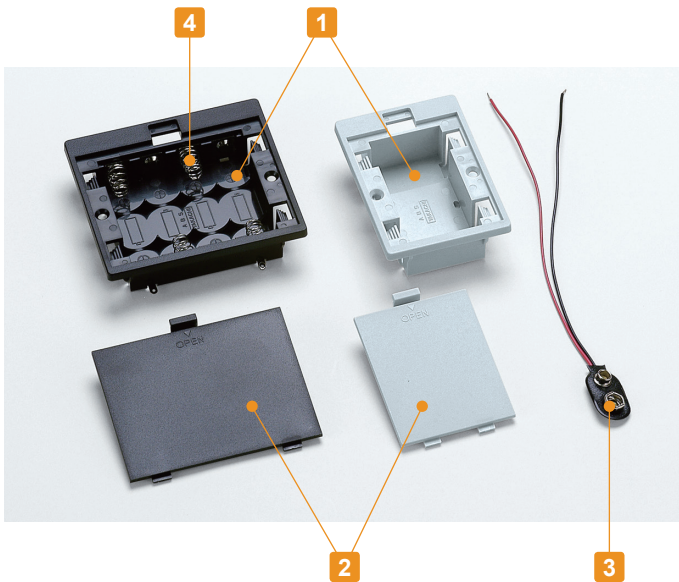

Accessories (Optional parts)

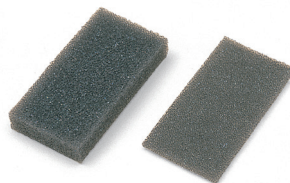

Battery cushion sponge SCM series  
See page BH9V-2 • SCM-1

Components (LD-006P models)

No.	Part name	Material	Color
1	Box	ABS (UL94HB) • PC+ABS (UL94V-0)	Black • Light gray • White
2	Cover	ABS (UL94HB) • PC+ABS (UL94V-0)	Black • Light gray • White
-	Battery snap (MP-ISN)	PVC + Copper wire (UL1007 AWG26)	Black • Red/Black

Components (LD-2 • LD-3 • LD-4 models)

No.	Part name	Material	Color
1	Box	ABS (UL94HB) • PC+ABS (UL94V-0)	Black • Light gray • White
2	Cover	ABS (UL94HB) • PC+ABS (UL94V-0)	Black • Light gray • White
3	Battery contact (IT-3 models)	Brass t = 0.3 • Steel wire Φ0.6	Nickel plated

**LD dimensions**

- DXF/DWG/PDF drawings available on our website.
- Battery contact position vary by models.
- See page MP-1 for the details of battery snap.

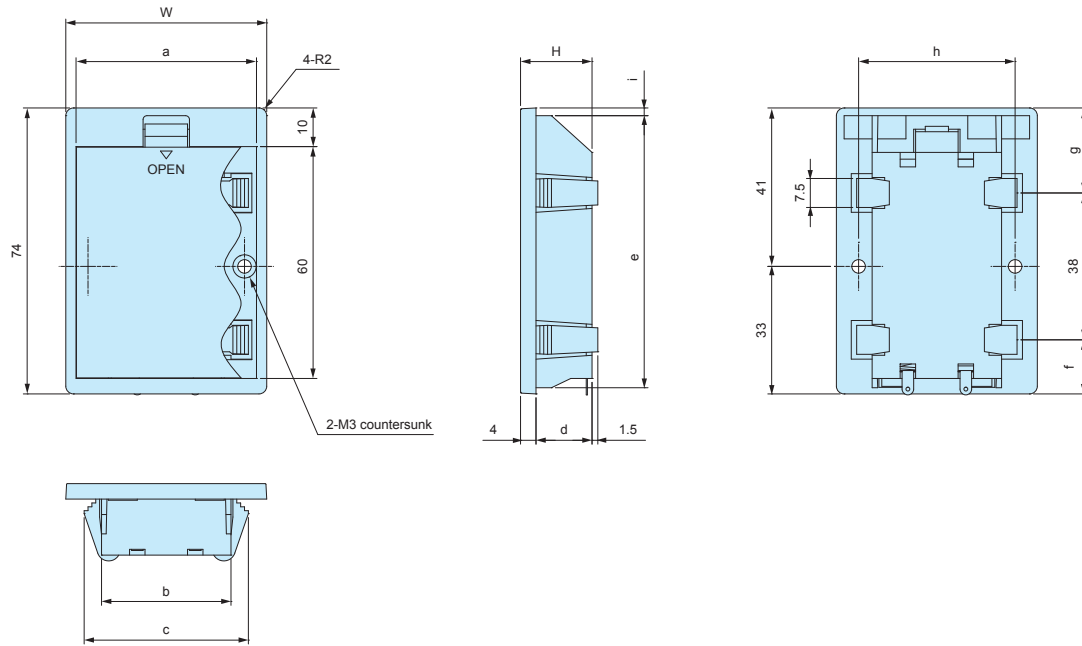

Product no.	W	H	a	b	c	d	e	f	g	h	i
LD-006P□	52	21.5	46.7	33.5	42.5	17.5	70.4	14	22	40.5	2
LD-2□	52	18.5	46.7	33.5	42.5	14.5	70.4	14	22	40.5	2
LD-3□	64.5	18.5	60.5	48	56.5	14.5	70.2	14.25	21.75	53	2.1
LD-4□	82	18.5	77	63.5	72.5	14.5	70.4	14	22	70.1	2

**Mounting hole**

※Snap-in mounting hole required would be  $D_1 \times W_1 \sim W_3$ .

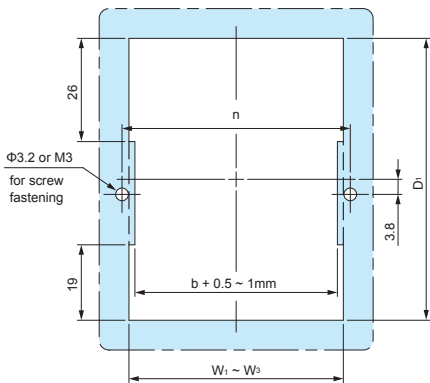

**Hole dimensions**

Product no.	W1 (thickness t = 1.0)	W2 (thickness t = 2.0)	W3 (thickness t = 3.0)	D <sub>1</sub>	n
LD-006P□ • LD-2□	36.5	38.5	40.5	70.6	40.5
LD-3□	51	52.5	54	70.4	53
LD-4□	66.5	68.5	70.5	70.6	70.1

- $W_1 \sim W_3$  values differ depending on panel thickness; see above table to determine required dimension.
- For mounting on panel thickness not listed above, please confirm before proceeding.

**Product no. / Feature**

Product no.			Matching battery	Weight (g)	Suitable cushion sponge
ABS	PC+ABS				
● Black	● Light gray	● White			
LD-006PB	LD-006PG	LD-006PW	9V x 1	24	SCM-2
LD-2B	LD-2G	LD-2W	AA x 2	24	SCM-1
LD-3B	LD-3G	LD-3W	AA x 3	26	SCM-1
LD-4B	LD-4G	LD-4W	AA x 4	35	SCM-1

**BH-9V-2**

**9V BATTERY HOLDER**

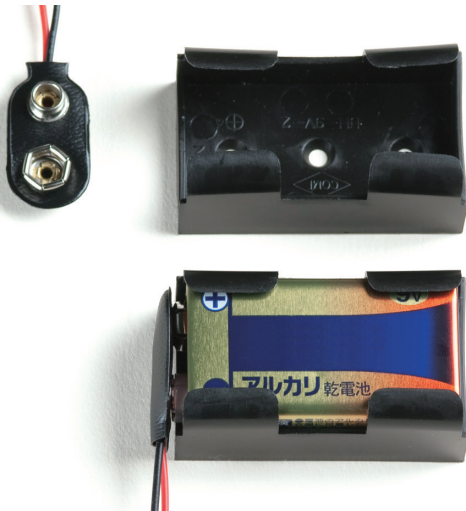

■ DXF/DWG/PDF drawings available on our website.

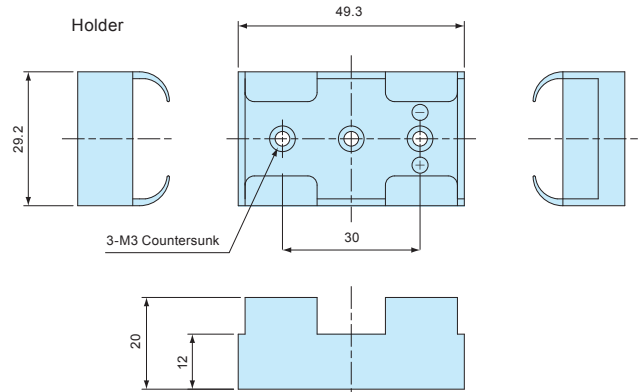

- 9V battery holder
- Battery snap comes with holder.

Technical Data
Operating temperature: -10°C ~ +60°C

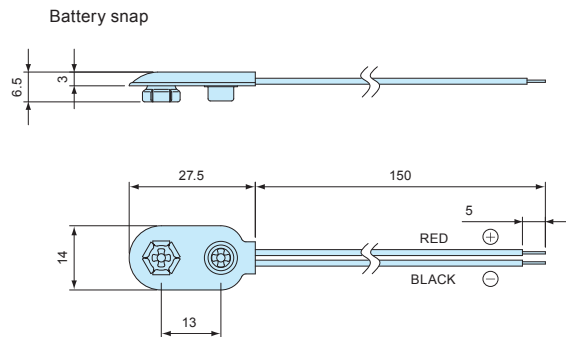

**Components**

Holder material	Holder color	Lead wire	Contact material	Battery snap cover	Contact surface finish
PP	Black	UL1007 AWG26 L=150	Brass	PVC	Nickel plated

**Product no. / Feature**

Product no.	Battery	Battery snap (included)	Weight (g)	Pack of
BH-9V-2	9V x 1	MP-1SN	6.8	1

**SCM SERIES**

**BATTERY CUSHION SPONGE**

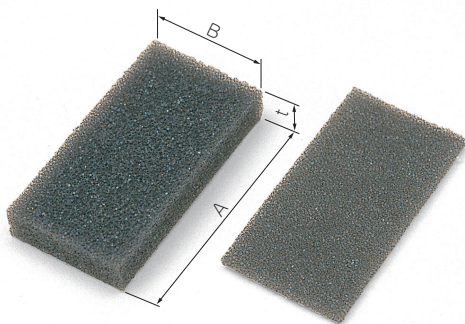

- Flame resistant moltoprene sponge with adhesive on the back side.
- Use to prevent battery from rattling inside the holder.

■ Material : Moltoprene (UL94HF-1)

**Suitable battery holder**

Product no.	Suitable battery holder
SCM-1	MD-2, MD-4, MD-006P, LD-2, LD-3, LD-4, LDN-2, LDN-3, LDN-4
SCM-2	LD-006P, LDN-006P
SCM-3	MD-006P

**Product no. / Dimensions**

Product no.	A	B	t	Pack of
SCM-1	50	25	2	10
SCM-2	50	25	4	10
SCM-3	50	25	7.5	10