

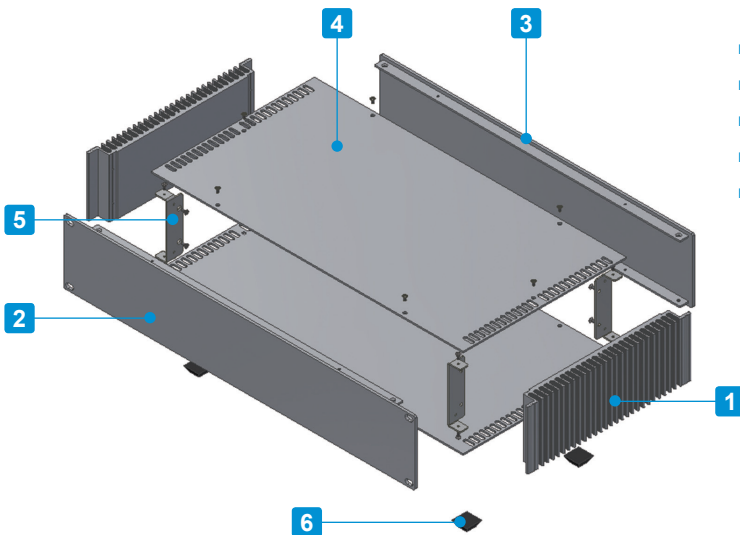

Heat Resistant



Technical Data
Protection class: IP40



- 8 different sizes, each with 2 color types available for selection.
- Stylish and elegantly designed with a hairline finish.
- Excellent cooling performance with the heat-sink side plates.
- Tough and robust enclosure from using aluminium extrusion parts.
- Simple and easy to assemble construction.

Components

No.	Part name	Pcs	Material	Color / Finish
1	Heat-sink side plate	2	Extruded aluminium A6063S-T5	Silver • Black / Anodized
2	Front panel	1	Extruded aluminium A6063S-T5	Silver • Black / Hairline brushed & Anodized
3	Rear panel	1	Extruded aluminium A6063S-T5	Silver • Black / Hairline brushed & Anodized
4	Top • Bottom cover	2	Aluminium A1050P t=2.0	Silver • Black / Hairline brushed & Anodized
5	Corner support	4	Steel SPCC t=1.6	Trivalent chromate
6	Rubber feet	4	Polyurethane	Black
-	Screw	1 set	Steel M3	Nickel plated • Black trivalent chromate

Accessories (Optional parts)

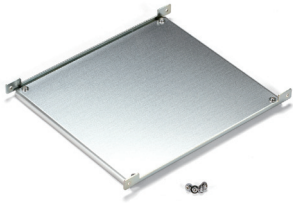

Mounting plate HYC series
See page HYC • HYCL-1



L-bracket HYCL series
See page HYC • HYCL-1



TORX screw MR3-5Z series
See page HY • HYR • HYRH-2



HYR dimensions (outside view)

■ Drawings below are reference examples only.
DXF/DWG/PDF drawings available on our website.

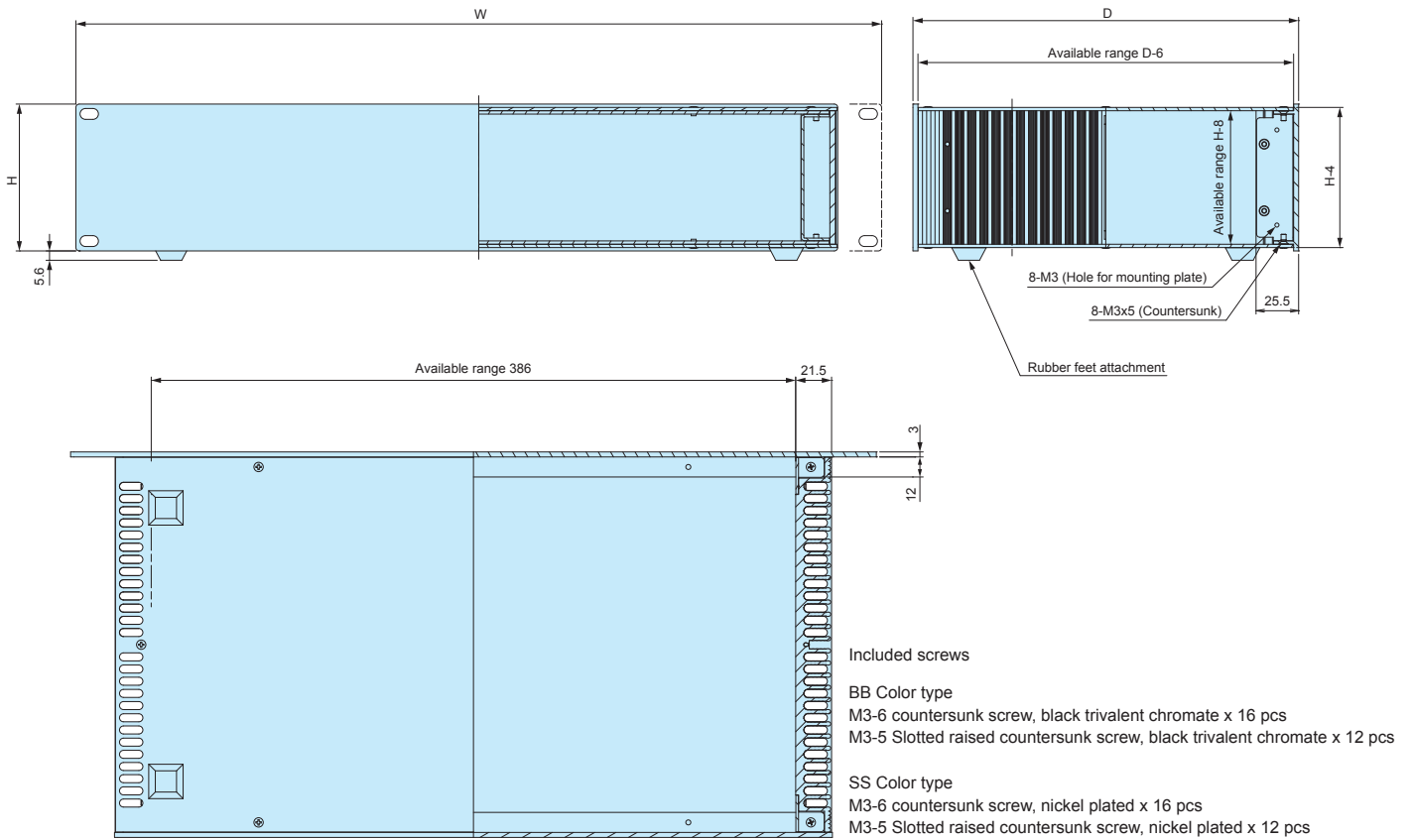

Product no. / Dimensions

Product no.		W	H	D	Standard	Weight (kg)
● Silver	● Black					
HYR 44-43-23SS	HYR 44-43-23BB	482.6	44	231	EIA	1.9
HYR 44-43-33SS	HYR 44-43-33BB	482.6	44	330	EIA	2.6
HYR 88-43-23SS	HYR 88-43-23BB	482.6	88	231	EIA	2.8
HYR 88-43-33SS	HYR 88-43-33BB	482.6	88	330	EIA	3.7
HYR133-43-23SS	HYR133-43-23BB	482.6	132.5	231	EIA	3.6
HYR133-43-33SS	HYR133-43-33BB	482.6	132.5	330	EIA	4.7
HYR177-43-23SS	HYR177-43-23BB	482.6	177	231	EIA	4.5
HYR177-43-33SS	HYR177-43-33BB	482.6	177	330	EIA	5.9

HYC SERIES

MOUNTING PLATE for HY · HYR · HYRH

■ Mounting plate and L-bracket set.

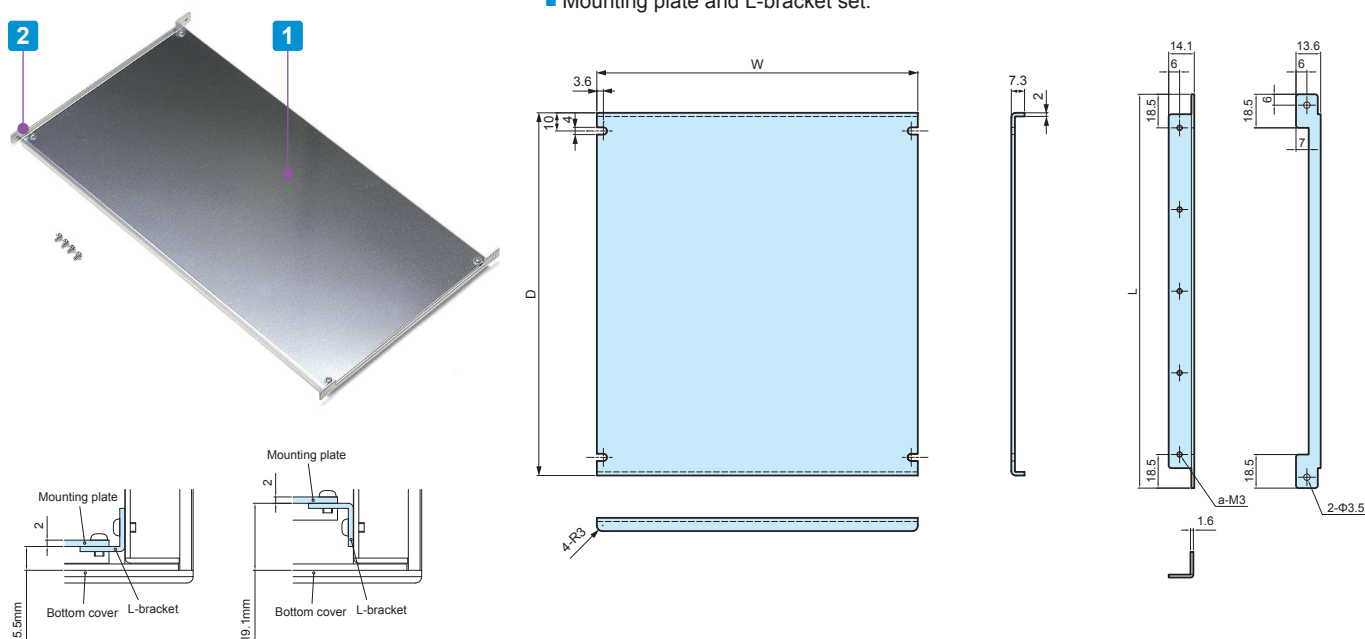

Components

No.	Part name	Pcs	Material	Color / Finish
1	Mounting plate	1	Aluminium A1050P t=2.0	Unfinished
2	L-bracket	2	Steel SPCC t=1.6	Tivalent chromate
?	Screw	1 set	Steel M3	Tivalent chromate

Product no. / Dimensions

Product no.	W	D	L	a	Suitable models	Weight (g)
HYC23-23	177	200	217	5	HY□-23-23	300
HYC23-28	227	200	217	5	HY□-28-23	350
HYC23-33	277	200	217	5	HY□-33-23	410
HYC23-43	377	200	217	5	HY□-43-23	520
HYC33-23	177	299	316	7	HY□-23-33	450
HYC33-28	227	299	316	7	HY□-28-33	550
HYC33-33	277	299	316	7	HY□-33-33	710
HYC33-43	377	299	316	7	HY□-43-33	800

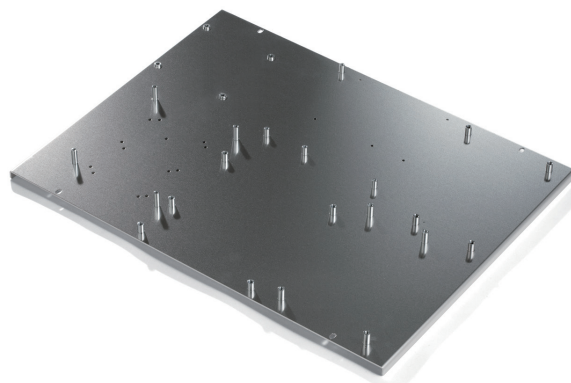

Clinching stud customization service available.

HYCL SERIES

L-bracket for HY · HYR · HYRH

- Simple L-bracket and screw set.
- Use with your original mounting plate or PCB.

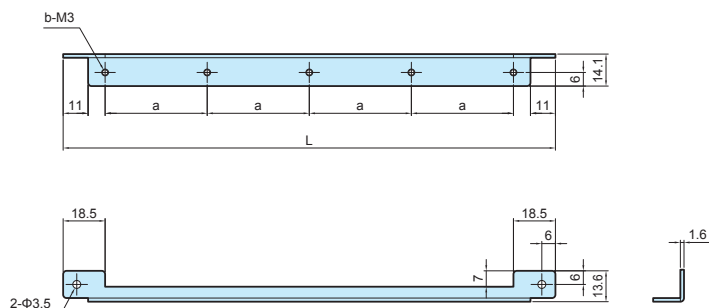

Components

No.	Part name	Material	Color / Finish
1	L-bracket	Steel t=1.6	Tivalent chromate
2	Screw	Steel M3	Tivalent chromate

Product no. / Dimensions

Product no.	L	a	b	Pack of
HYCL-23	217	45	5	2
HYCL-33	316	46.5	7	2

HY dimensions (outside view)

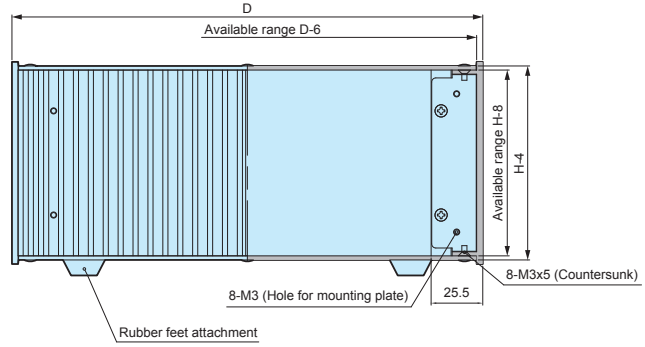
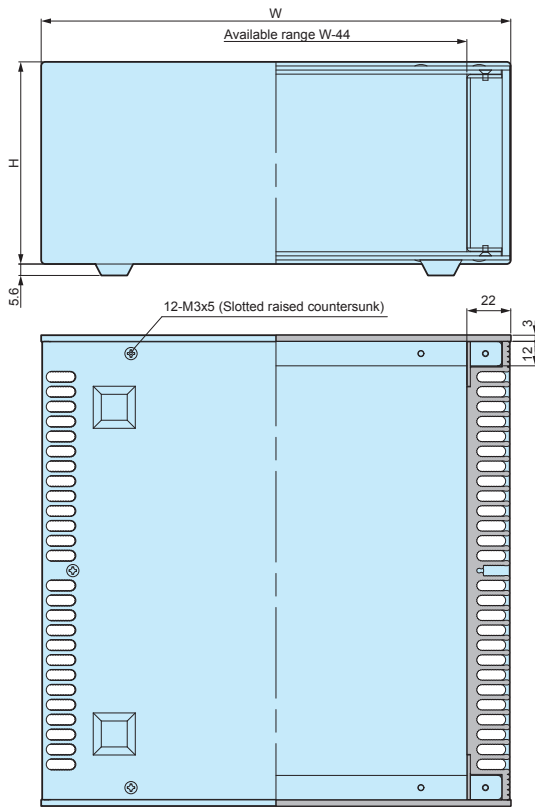

Included screws

BB Color type

M3-6 countersunk screw, black trivalent chromate x 16 pcs

M3-5 Slotted raised countersunk screw, black trivalent chromate x 12 pcs

SS Color type

M3-6 countersunk screw, nickel plated x 16 pcs

M3-5 Slotted raised countersunk screw, nickel plated x 12 pcs

Component Parts Drawings

HY • HYR • HYRH top / bottom cover

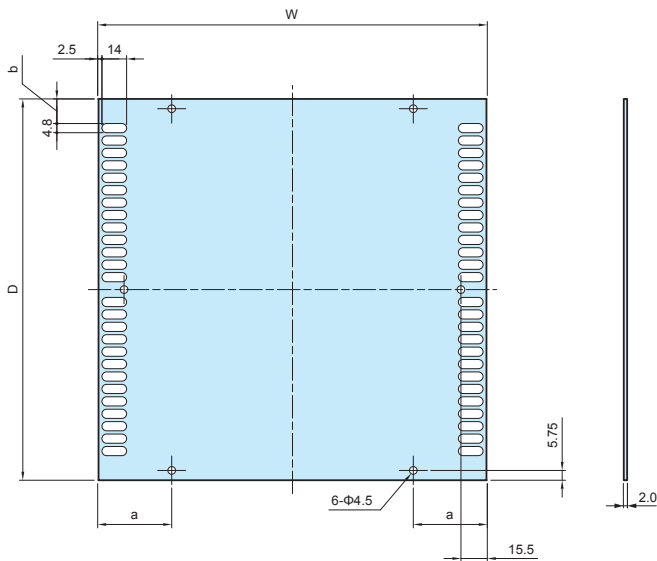

Color Type

Code	Material	Color / Finish
SS	Aluminium A1050P t = 2.0	Silver / Hairline brushed & Anodized
BB	Aluminium A1050P t = 2.0	Black / Hairline brushed & Anodized

Dimensions

Enclosure W x D	W	D	a	b
230 x 231	229	224.5	45.7	14.95
230 x 330	229	323.5	45.7	15.1
280 x 231	279	224.5	55.8	14.95
280 x 330	279	323.5	55.8	15.1
330 x 231	329	224.5	65.8	14.95
330 x 330	329	323.5	65.8	15.1
430 x 231	429	224.5	85.8	14.95
430 x 330	429	323.5	85.8	15.1

HY front / rear panels & HYR • HYRH rear panel

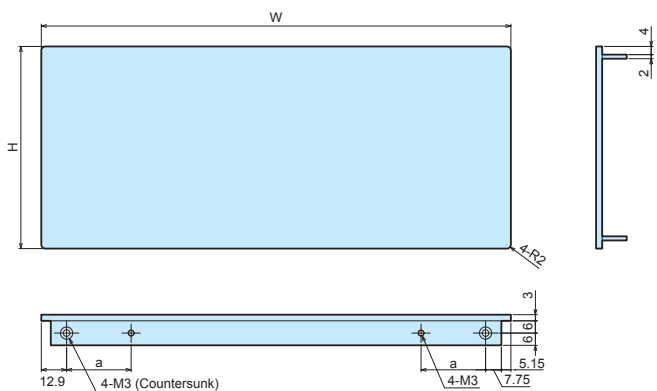

Color Type

Code	Material	Color / Finish
SS	Extruded aluminium A6063S-T5	Silver / Hairline brushed & Anodized
BB	Extruded aluminium A6063S-T5	Black / Hairline brushed & Anodized

Dimensions

Enclosure W	W	a	H(44)	H(70)	H(88)	H(99)	H(132.5)	H(149)	H(177)
230	230	33.3	44	70	88	99	132.5	149	177
280	280	43.4	44	70	88	99	132.5	149	177
330	330	53.4	44	70	88	99	132.5	149	177
430	430	73.4	44	70	88	99	132.5	149	177

HY • HYR • HYRH heat-sink side plate

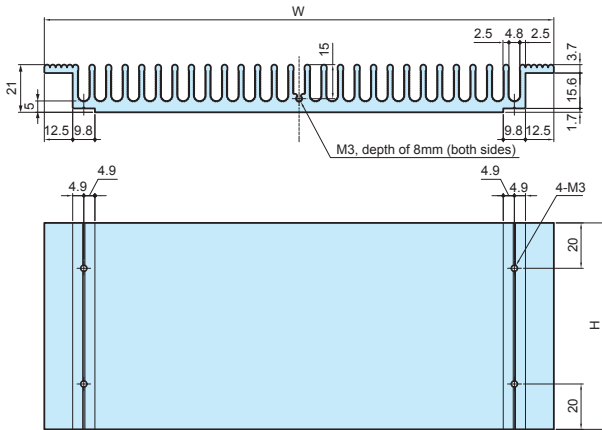

Color Type

Code	Material	Color / Finish
SS	Extruded aluminium A6063S-T5	Silver / Anodized
BB	Extruded aluminium A6063S-T5	Black / Anodized

Dimensions

Enclosure D x H	W	H	Thermal resistance (°C/W)
231 × 44	224.6	36	2.41
330 × 44	323.6	36	1.89
231 × 70	224.6	62	1.49
330 × 70	323.6	62	1.36
231 × 88	224.6	80	1.49
330 × 88	323.6	80	1.17
231 × 99	224.6	91	1.38
330 × 99	323.6	91	1.08
231 × 132.5	224.6	124.5	1.14
330 × 132.5	323.6	124.5	0.89
231 × 149	224.6	141	1.06
330 × 149	323.6	141	0.83
231 × 177	224.6	169	0.95
330 × 177	323.6	169	0.74

■ Thermal resistance calculation is based on the fins being perpendicular to the ground with temperature at 60°C.

HY • HYR • HYRH corner support

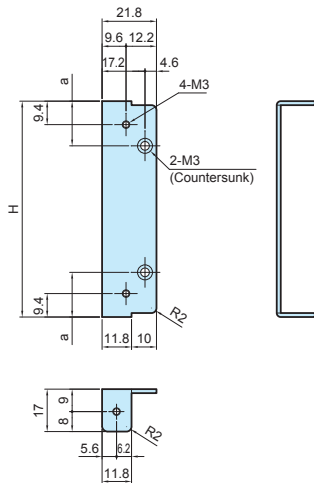

Part Information

Part name	Material	Finish
Corner support	Steel t=1.6	Trivalent chromate

Dimensions

Enclosure H	H	a
44	31.8	10.9
70	57.8	17.9
88	75.8	17.9
99	86.8	17.9
132.5	120.3	17.9
149	136.8	17.9
177	164.8	17.9

HY • HYR • HYRH rubber feet

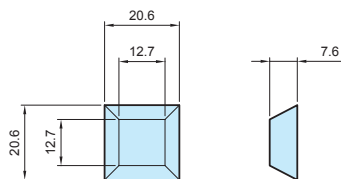

Part Information

Part name	Material	Color
Rubber feet	Polyurethane	Black

Accessories (Optional parts)

MR SERIES

SLOTTED RAISED COUNTERSUNK TORX SCREW



- For use with top/bottom cover.
- Recommended for aesthetic purposes, or for tampering resistance.
- Requires the use of a specialized screwdriver.

Product no. / Dimensions

Product no.	M	L	TORX head no.	Material	Color / Finish	Pack of
MR3-5ZS	3	5	T10	Steel	Nickel plated	20
MR3-5ZB	3	5	T10	Steel	Black trivalent chromate	20