

HYR series Rack Mount
HYRH series Rack Mount with handle
Variations of HY series, HYR and HYRH series are also available. See website for more details.

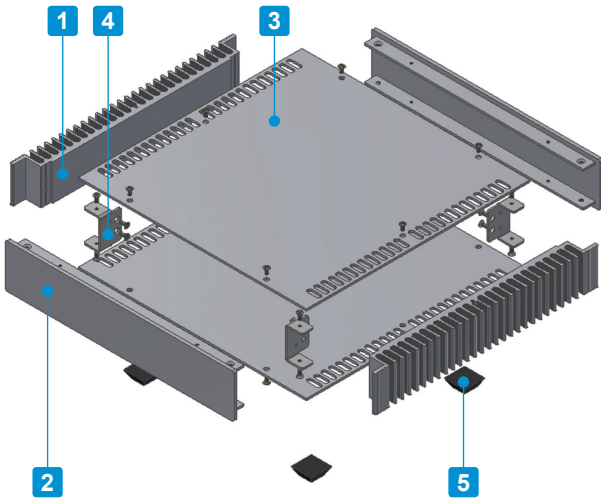

- Stylish and elegantly designed with a hairline finish.
- Excellent cooling performance with the heat-sink side plates.
- Now available in 56 sizes, and 2 different colors.
- Tough and robust enclosure from using aluminium extrusion parts.
- Simple and easy to assemble construction.
- Flat back heat-sink plates for more effective heat spreading.

Included screws

BB color type

M3-6 countersunk • Black trivalent chromate x 16 pcs
M3-5 Slotted raised countersunk • Black trivalent chromate x 12 pcs

SS color type

M3-6 countersunk • Nickel plated x 16 pcs
M3-5 Slotted raised countersunk • Nickel plated x 12 pcs

Components

No.	Part name	Pcs	Material	Color / Finish
1	Heat-sink side plate	2	Extruded aluminium A6063S-T5	Silver • Black / Anodized
2	Panel	2	Extruded aluminium A6063S-T5	Silver • Black / Hairline brushed & Anodized
3	Top • Bottom cover	2	Aluminium A1050P t=2.0	Silver • Black / Hairline brushed & Anodized
4	Corner support	4	Steel SPCC t=1.6	Trivalent chromate
5	Rubber feet	4	Polyurethane	Black

※HL = Hairline brushed

Accessories (Optional parts)

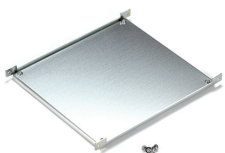

Mounting plate HYC series
See page HYC • HYCL-1



L-bracket HYCL series
See page HYC • HYCL-1



Aluminium isolation feet AFS • AFM series
See page AFS • AFM-1 ~ 2



TORX screw - for top / bottom cover MR3-5Z series
See page HY • HYR • HYRH-2



■ Drawings below are reference examples only.
DXF/DWG/PDF drawings available on our website.

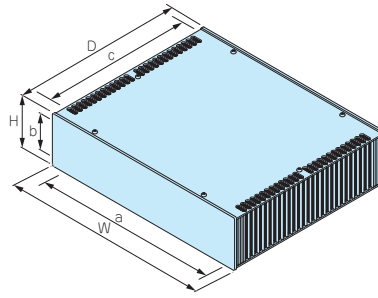

Product no.		Dimensions (External)			Dimensions (Internal)			Weight (kg)
● Silver	● Black	W	H	D	a	b	c	
HY 44-23-23SS	HY 44-23-23BB	230	44	231	186	36	225	1.1
HY 44-23-33SS	HY 44-23-33BB	230	44	330	186	36	324	1.6
HY 44-28-23SS	HY 44-28-23BB	280	44	231	196	36	225	1.4
HY 44-28-33SS	HY 44-28-33BB	280	44	330	196	36	324	1.9
HY 44-33-23SS	HY 44-33-23BB	330	44	231	286	36	225	1.5
HY 44-33-33SS	HY 44-33-33BB	330	44	330	286	36	324	2.2
HY 44-43-23SS	HY 44-43-23BB	430	44	231	386	36	225	1.9
HY 44-43-33SS	HY 44-43-33BB	430	44	330	386	36	324	2.6
HY 70-23-23SS	HY 70-23-23BB	230	70	231	186	62	225	1.6
HY 70-23-33SS	HY 70-23-33BB	230	70	330	186	62	324	2.2
HY 70-28-23SS	HY 70-28-23BB	280	70	231	196	62	225	1.8
HY 70-28-33SS	HY 70-28-33BB	280	70	330	196	62	324	2.5
HY 70-33-23SS	HY 70-33-23BB	330	70	231	286	62	225	2.0
HY 70-33-33SS	HY 70-33-33BB	330	70	330	286	62	324	2.8
HY 70-43-23SS	HY 70-43-23BB	430	70	231	386	62	225	2.3
HY 70-43-33SS	HY 70-43-33BB	430	70	330	386	62	324	3.2
HY 88-23-23SS	HY 88-23-23BB	230	88	231	186	80	225	1.9
HY 88-23-33SS	HY 88-23-33BB	230	88	330	186	80	324	2.6
HY 88-28-23SS	HY 88-28-23BB	280	88	231	196	80	225	2.1
HY 88-28-33SS	HY 88-28-33BB	280	88	330	196	80	324	2.8
HY 88-33-23SS	HY 88-33-23BB	330	88	231	286	80	225	2.3
HY 88-33-33SS	HY 88-33-33BB	330	88	330	286	80	324	3.1
HY 88-43-23SS	HY 88-43-23BB	430	88	231	386	80	225	2.7
HY 88-43-33SS	HY 88-43-33BB	430	88	330	386	80	324	3.6
HY 99-23-23SS	HY 99-23-23BB	230	99	231	186	91	225	2.1
HY 99-23-33SS	HY 99-23-33BB	230	99	330	186	91	324	2.7
HY 99-28-23SS	HY 99-28-23BB	280	99	231	196	91	225	2.3
HY 99-28-33SS	HY 99-28-33BB	280	99	330	196	91	324	3.1
HY 99-33-23SS	HY 99-33-23BB	330	99	231	286	91	225	2.5
HY 99-33-33SS	HY 99-33-33BB	330	99	330	286	91	324	3.4
HY 99-43-23SS	HY 99-43-23BB	430	99	231	386	91	225	2.9
HY 99-43-33SS	HY 99-43-33BB	430	99	330	386	91	324	3.9
HY133-23-23SS	HY133-23-23BB	230	132.5	231	186	124.5	225	2.6
HY133-23-33SS	HY133-23-33BB	230	132.5	330	186	124.5	324	3.4
HY133-28-23SS	HY133-28-23BB	280	132.5	231	196	124.5	225	2.8
HY133-28-33SS	HY133-28-33BB	280	132.5	330	196	124.5	324	3.8
HY133-33-23SS	HY133-33-23BB	330	132.5	231	286	124.5	225	3.0
HY133-33-33SS	HY133-33-33BB	330	132.5	330	286	124.5	324	4.1
HY133-43-23SS	HY133-43-23BB	430	132.5	231	386	124.5	225	3.5
HY133-43-33SS	HY133-43-33BB	430	132.5	330	386	124.5	324	4.7
HY149-23-23SS	HY149-23-23BB	230	149	231	186	141	225	2.8
HY149-23-33SS	HY149-23-33BB	230	149	330	186	141	324	3.8
HY149-28-23SS	HY149-28-23BB	280	149	231	196	141	225	3.1
HY149-28-33SS	HY149-28-33BB	280	149	330	196	141	324	4.2
HY149-33-23SS	HY149-33-23BB	330	149	231	286	141	225	3.3
HY149-33-33SS	HY149-33-33BB	330	149	330	286	141	324	4.5
HY149-43-23SS	HY149-43-23BB	430	149	231	386	141	225	3.8
HY149-43-33SS	HY149-43-33BB	430	149	330	386	141	324	5.1
HY177-23-23SS	HY177-23-23BB	230	177	231	186	169	225	3.4
HY177-23-33SS	HY177-23-33BB	230	177	330	186	169	324	4.5
HY177-28-23SS	HY177-28-23BB	280	177	231	196	169	225	3.6
HY177-28-33SS	HY177-28-33BB	280	177	330	196	169	324	4.8
HY177-33-23SS	HY177-33-23BB	330	177	231	286	169	225	3.9
HY177-33-33SS	HY177-33-33BB	330	177	330	286	169	324	5.2
HY177-43-23SS	HY177-43-23BB	430	177	231	386	169	225	4.5
HY177-43-33SS	HY177-43-33BB	430	177	330	386	169	324	5.8

HY SERIES APPLICATION EXAMPLE

COMPLETE BALANCED SPECIAL TUNED DC HEADPHONE AMPLIFIER

Product by Sanyo Kasei (Japan)



ENERGY CREATION POWER CONDITIONER DEVELOPMENT KIT

Product by Smart Energy Laboratory (Japan)



LINEAR POWER SUPPLY

Product by UpTone Audio (USA)

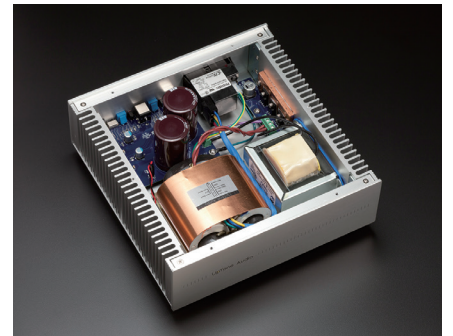

INDUSTRIAL FANLESS COMPUTER

Product by Techno Veins (Japan)

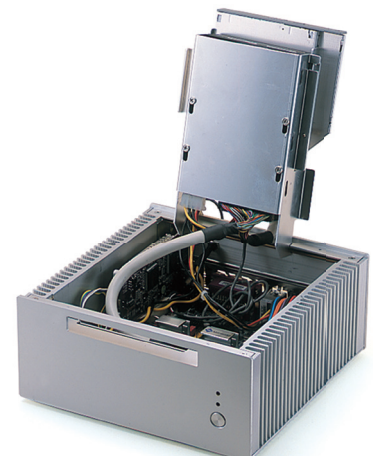

HYC SERIES

MOUNTING PLATE for HY · HYR · HYRH

■ Mounting plate and L-bracket set.

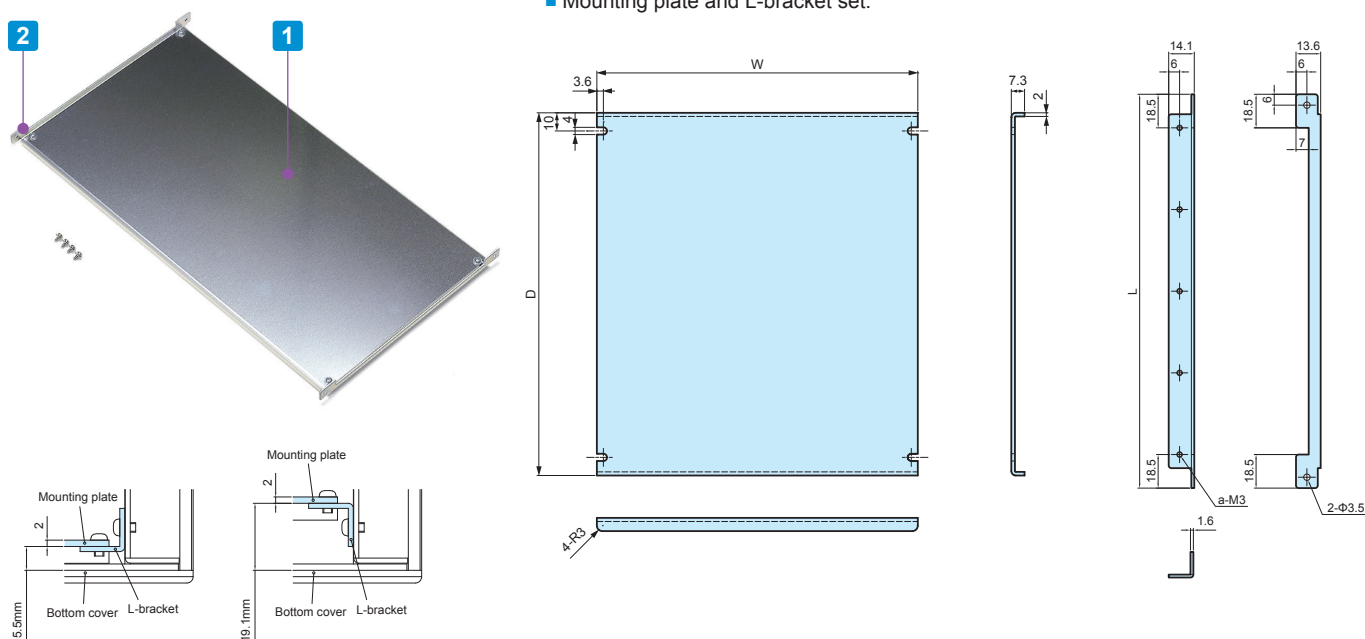

Components

No.	Part name	Pcs	Material	Color / Finish
1	Mounting plate	1	Aluminium A1050P t=2.0	Unfinished
2	L-bracket	2	Steel SPCC t=1.6	Tivalent chromate
?	Screw	1 set	Steel M3	Tivalent chromate

Product no. / Dimensions

Product no.	W	D	L	a	Suitable models	Weight (g)
HYC23-23	177	200	217	5	HY□-23-23	300
HYC23-28	227	200	217	5	HY□-28-23	350
HYC23-33	277	200	217	5	HY□-33-23	410
HYC23-43	377	200	217	5	HY□-43-23	520
HYC33-23	177	299	316	7	HY□-23-33	450
HYC33-28	227	299	316	7	HY□-28-33	550
HYC33-33	277	299	316	7	HY□-33-33	710
HYC33-43	377	299	316	7	HY□-43-33	800

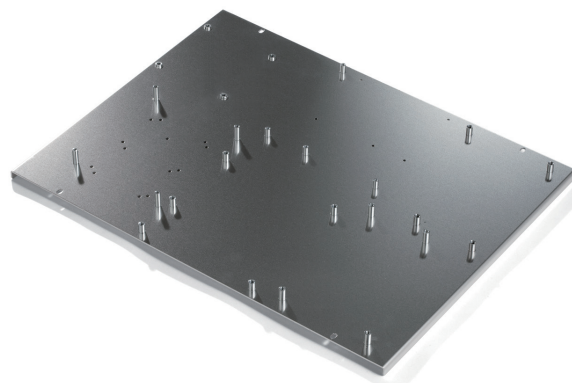

Clinching stud customization service available.

HYCL SERIES

L-bracket for HY · HYR · HYRH

- Simple L-bracket and screw set.
- Use with your original mounting plate or PCB.

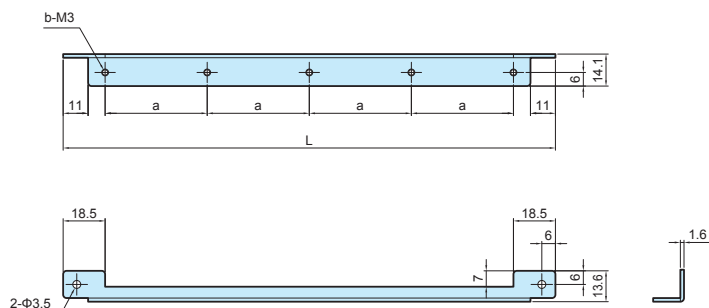

Components

No.	Part name	Material	Color / Finish
1	L-bracket	Steel t=1.6	Tivalent chromate
2	Screw	Steel M3	Tivalent chromate

Product no. / Dimensions

Product no.	L	a	b	Pack of
HYCL-23	217	45	5	2
HYCL-33	316	46.5	7	2

HY dimensions (outside view)

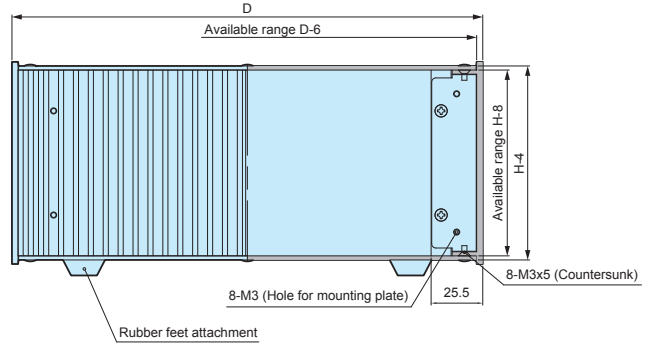
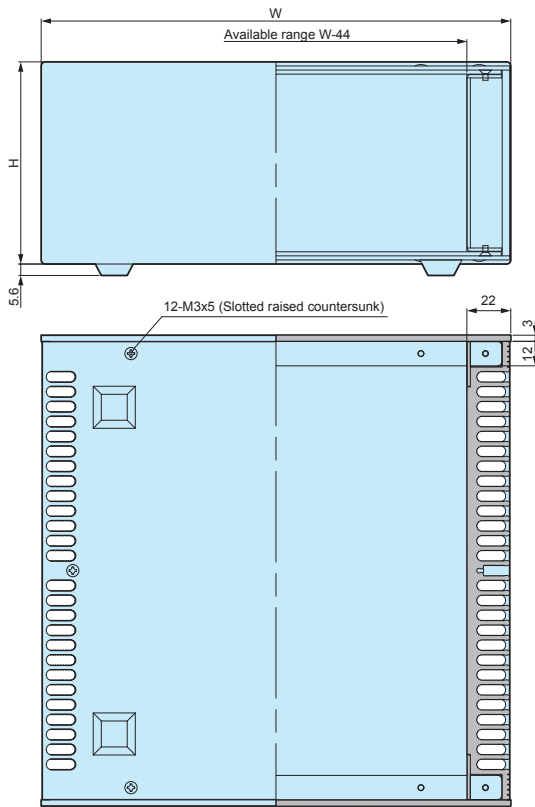

Included screws

BB Color type

M3-6 countersunk screw, black trivalent chromate x 16 pcs

M3-5 Slotted raised countersunk screw, black trivalent chromate x 12 pcs

SS Color type

M3-6 countersunk screw, nickel plated x 16 pcs

M3-5 Slotted raised countersunk screw, nickel plated x 12 pcs

Component Parts Drawings

HY • HYR • HYRH top / bottom cover

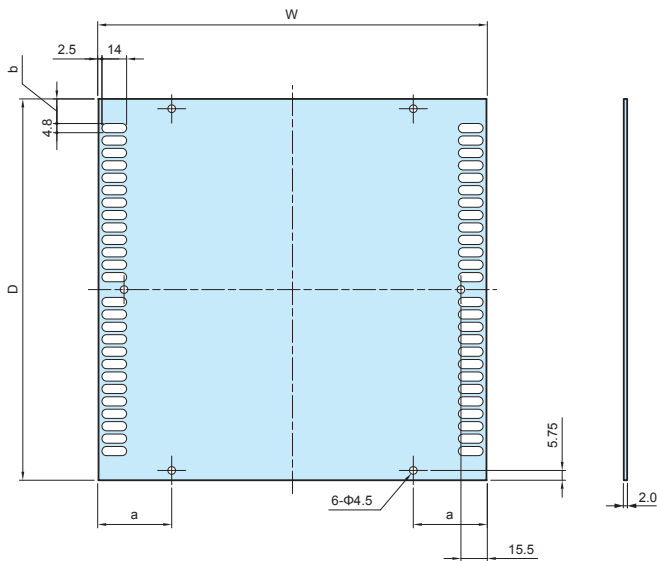

Color Type

Code	Material	Color / Finish
SS	Aluminium A1050P t = 2.0	Silver / Hairline brushed & Anodized
BB	Aluminium A1050P t = 2.0	Black / Hairline brushed & Anodized

Dimensions

Enclosure W x D	W	D	a	b
230 x 231	229	224.5	45.7	14.95
230 x 330	229	323.5	45.7	15.1
280 x 231	279	224.5	55.8	14.95
280 x 330	279	323.5	55.8	15.1
330 x 231	329	224.5	65.8	14.95
330 x 330	329	323.5	65.8	15.1
430 x 231	429	224.5	85.8	14.95
430 x 330	429	323.5	85.8	15.1

HY front / rear panels & HYR • HYRH rear panel

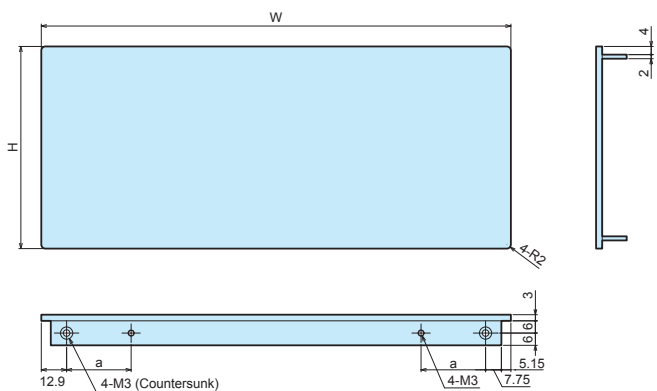

Color Type

Code	Material	Color / Finish
SS	Extruded aluminium A6063S-T5	Silver / Hairline brushed & Anodized
BB	Extruded aluminium A6063S-T5	Black / Hairline brushed & Anodized

Dimensions

Enclosure W	W	a	H(44)	H(70)	H(88)	H(99)	H(132.5)	H(149)	H(177)
230	230	33.3	44	70	88	99	132.5	149	177
280	280	43.4	44	70	88	99	132.5	149	177
330	330	53.4	44	70	88	99	132.5	149	177
430	430	73.4	44	70	88	99	132.5	149	177

HY • HYR • HYRH heat-sink side plate

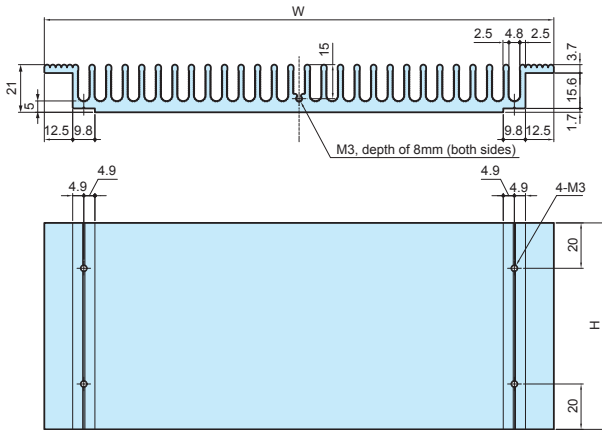

Color Type

Code	Material	Color / Finish
SS	Extruded aluminium A6063S-T5	Silver / Anodized
BB	Extruded aluminium A6063S-T5	Black / Anodized

Dimensions

Enclosure D x H	W	H	Thermal resistance (°C/W)
231 × 44	224.6	36	2.41
330 × 44	323.6	36	1.89
231 × 70	224.6	62	1.49
330 × 70	323.6	62	1.36
231 × 88	224.6	80	1.49
330 × 88	323.6	80	1.17
231 × 99	224.6	91	1.38
330 × 99	323.6	91	1.08
231 × 132.5	224.6	124.5	1.14
330 × 132.5	323.6	124.5	0.89
231 × 149	224.6	141	1.06
330 × 149	323.6	141	0.83
231 × 177	224.6	169	0.95
330 × 177	323.6	169	0.74

■ Thermal resistance calculation is based on the fins being perpendicular to the ground with temperature at 60°C.

HY • HYR • HYRH corner support

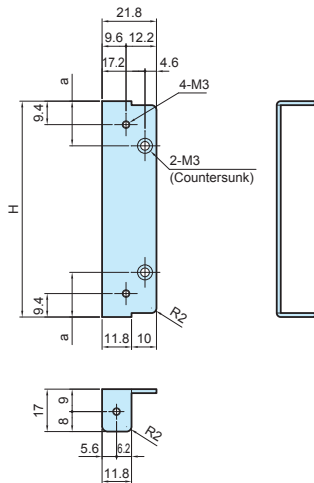

Part Information

Part name	Material	Finish
Corner support	Steel t=1.6	Trivalent chromate

Dimensions

Enclosure H	H	a
44	31.8	10.9
70	57.8	17.9
88	75.8	17.9
99	86.8	17.9
132.5	120.3	17.9
149	136.8	17.9
177	164.8	17.9

HY • HYR • HYRH rubber feet

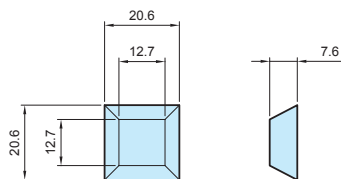

Part Information

Part name	Material	Color
Rubber feet	Polyurethane	Black

Accessories (Optional parts)

MR SERIES

SLOTTED RAISED COUNTERSUNK TORX SCREW



- For use with top/bottom cover.
- Recommended for aesthetic purposes, or for tampering resistance.
- Requires the use of a specialized screwdriver.

Product no. / Dimensions

Product no.	M	L	TORX head no.	Material	Color / Finish	Pack of
MR3-5ZS	3	5	T10	Steel	Nickel plated	20
MR3-5ZB	3	5	T10	Steel	Black trivalent chromate	20

AFS•AFM SERIES

ALUMINIUM ISOLATION FEET



- The surface treatment and finish allows the feet to exhibit a polished and luxurious feel.
- Non-slip NBR O-ring is present on the underside of the feet.
- Suitable for use in audio devices.

Available in both internal and external screw installation type.

External type / Shot blast finish (AFS series)



The external type is secured via screws from the underside / base of the feet to the enclosure. A thread hole is required for direct securing, while a circular hole is required for lock nut securing.

The shot blast finish provides a high quality surface finish look, and pairing well with various types of enclosure surfaces.

Available in both silver and black.

Internal type / Reflective finish (AFM series)



The internal type is secured via screws from the inside of the enclosure. A circular hole is required for securing into the pre-made threads in the top-side of the feet.

The reflective surface finish adds a high quality touch to the unit, allow it to have a luxurious look.

Available only in Silver.

Accessories (Optional parts)

Product no. / Dimensions

Product no.		D	H	Installation type	C	a	b	Pack of
● Silver	● Black							
AFS20- 8S	AFS20- 8B	20	8	External	Φ3.4	3	9	4
AFS25-10S	AFS25-10B	25	10	External	Φ4.5	4	12	4
AFS30-12S	AFS30-12B	30	12	External	Φ4.5	5	12	4
AFS35-14S	AFS35-14B	35	14	External	Φ4.5	5	12	4
AFS39-16S	AFS39-16B	39	16	External	Φ4.5	5	15	4
AFS44-18S	AFS44-18B	44	18	External	Φ4.5	5	20	4
AFS55-20S	AFS55-20B	55	20	External	Φ5.5	5	20	4
AFM15- 7S	-	15	7	Internal	M3	4	-	4
AFM20- 9S	-	20	9	Internal	M3	5	-	4
AFM25-12S	-	25	12	Internal	M4	7	-	4
AFM30-14S	-	30	14	Internal	M4	8	-	4
AFM35-16S	-	35	16	Internal	M4	10	-	4
AFM39-18S	-	39	18	Internal	M4	10	-	4
AFM44-20S	-	44	20	Internal	M4	10	-	4
AFM55-22S	-	55	22	Internal	M5	15	-	4

AFS • AFM dimensions

■ Drawings below are reference examples only.
DXF/DWG/PDF drawings available on our website.

AFS SERIES

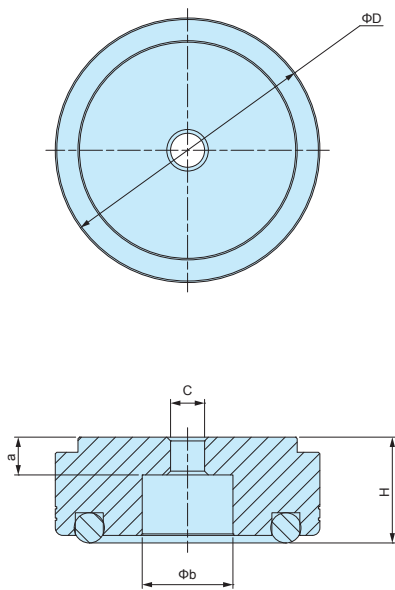

AFM SERIES

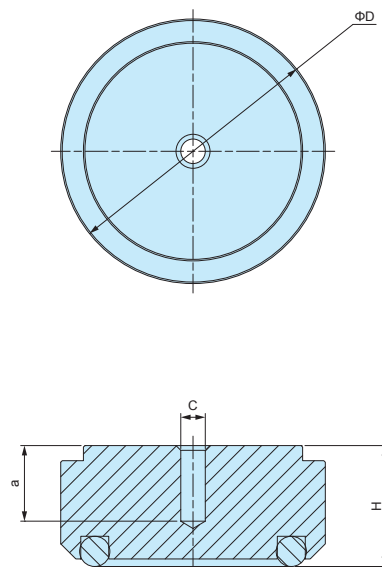

APPLICATION EXAMPLE

