

FCC SERIES

MOUNTING PLATE for FC • FCW

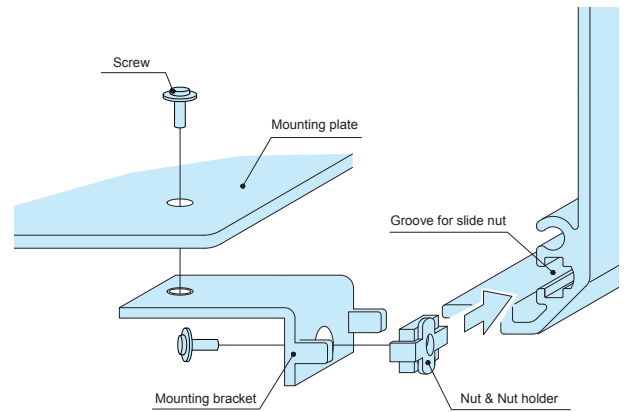
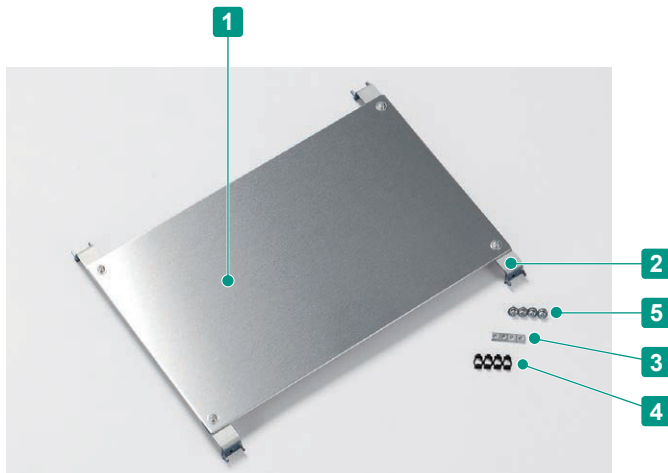

How to assemble

- ① Slide a M3 nut and nut holder into the groove on the frame.
- ② Screw the mounting bracket into the nut holder.
- ③ Screw the mounting plate onto the mounting bracket.

- The mounting bracket comes in 2 different height versions, 12mm and 22mm.
- Use 22mm height version when set on the open/close panel side of FCW series.
- Not suitable for FC4 (H = 37.9mm)
- Mounting brackets (FCK) are included with FCC series.
- DXF/DWG/PDF drawings available on our website.

Components

No.	Part name	Material	Color / Finish
1	Mounting plate	Aluminium A1050P t=2.0	Unfinished
2	Mounting bracket	Steel SECC t=1.6	Zinc coated
3	M3 nut	Steel SPCC t=1.6	Trivalent chromate
4	Nut holder	POM	Black
5	Screw	Steel M3-6	Trivalent chromate

For box size (W x D or D x W) 100 x 100mm to 350 x 300mm

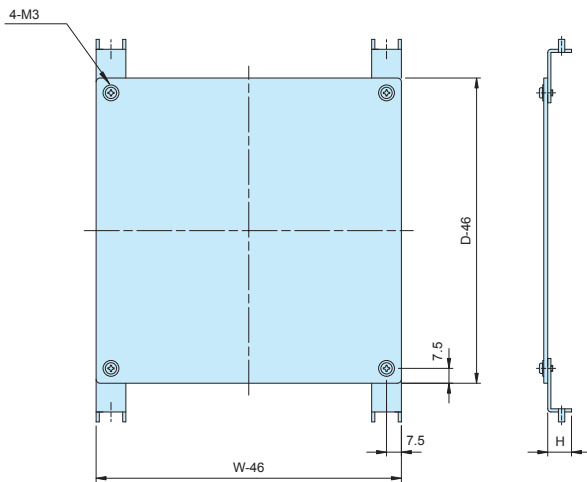

For box size (W x D or D x W) 400/500/600 x 200/250/300 mm

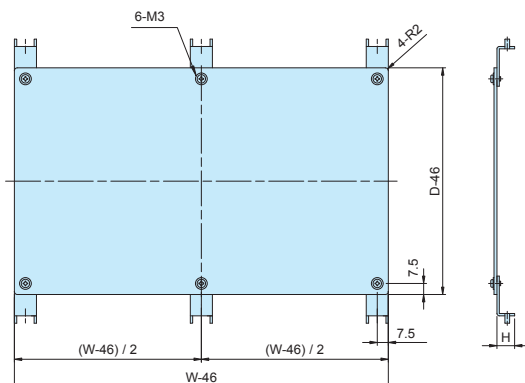

Product no. / Dimensions

Product no.	H	Box W x D or D x W	Product no.	H	Box W x D or D x W
FCC10-10-1	12	100×100	FCC10-10-2	22	100×100
FCC15-10-1	12	150×100	FCC15-10-2	22	150×100
FCC15-15-1	12	150×150	FCC15-15-2	22	150×150
FCC20-10-1	12	200×100	FCC20-10-2	22	200×100
FCC20-15-1	12	200×150	FCC20-15-2	22	200×150
FCC20-20-1	12	200×200	FCC20-20-2	22	200×200
FCC25-15-1	12	250×150	FCC25-15-2	22	250×150
FCC25-20-1	12	250×200	FCC25-20-2	22	250×200
FCC25-25-1	12	250×250	FCC25-25-2	22	250×250
FCC30-15-1	12	300×150	FCC30-15-2	22	300×150
FCC30-20-1	12	300×200	FCC30-20-2	22	300×200
FCC30-25-1	12	300×250	FCC30-25-2	22	300×250
FCC30-30-1	12	300×300	FCC30-30-2	22	300×300
FCC35-20-1	12	350×200	FCC35-20-2	22	350×200
FCC35-25-1	12	350×250	FCC35-25-2	22	350×250
FCC35-30-1	12	350×300	FCC35-30-2	22	350×300

Included screws: M3-6 pan head trivalent chromate with flat washer x 8 pcs

Product no. / Dimensions

Product no.	H	Box W x D or D x W	Product no.	H	Box W x D or D x W
FCC40-20-1	12	400×200	FCC40-20-2	22	400×200
FCC40-25-1	12	400×250	FCC40-25-2	22	400×250
FCC40-30-1	12	400×300	FCC40-30-2	22	400×300
FCC50-25-1	12	500×250	FCC50-25-2	22	500×250
FCC50-30-1	12	500×300	FCC50-30-2	22	500×300
FCC60-30-1	12	600×300	FCC60-30-2	22	600×300

Included screws: M3-6 pan head trivalent chromate with flat washer x 12 pcs

For box size (W x D or D x W) 400/500/600 x 400mm

■ DXF/DWG/PDF drawings available on our website.

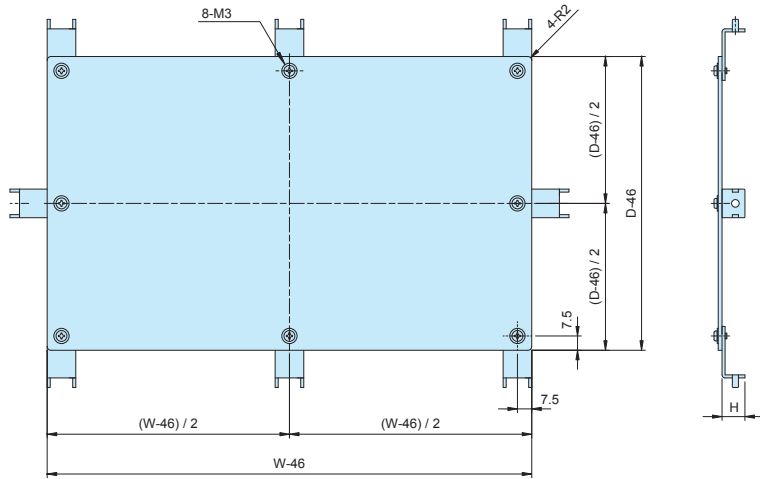

Product no. / Dimensions

Product no.	H	Box W x D or D x W	Product no.	H	Box W x D or D x W
FCC40-40-1	12	400x400	FCC40-40-2	22	400x400
FCC50-40-1	12	500x400	FCC50-40-2	22	500x400
FCC60-40-1	12	600x400	FCC60-40-2	22	600x400

Included screws: M3-6 pan head trivalent chromate with flat washer x 16 pcs

Accessories (Optional parts)

FCK SERIES MOUNTING BRACKET

■ DXF/DWG/PDF drawings available on our website.

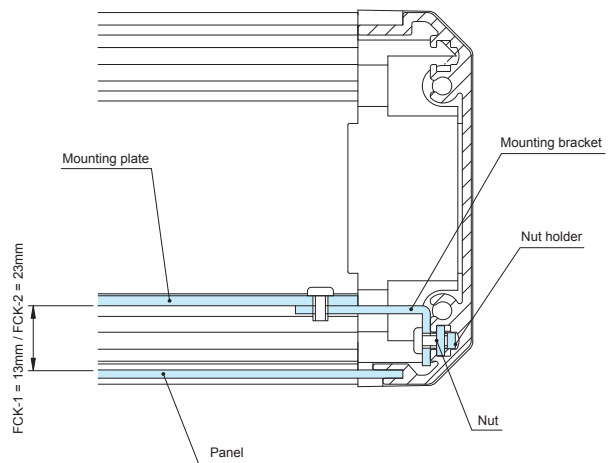
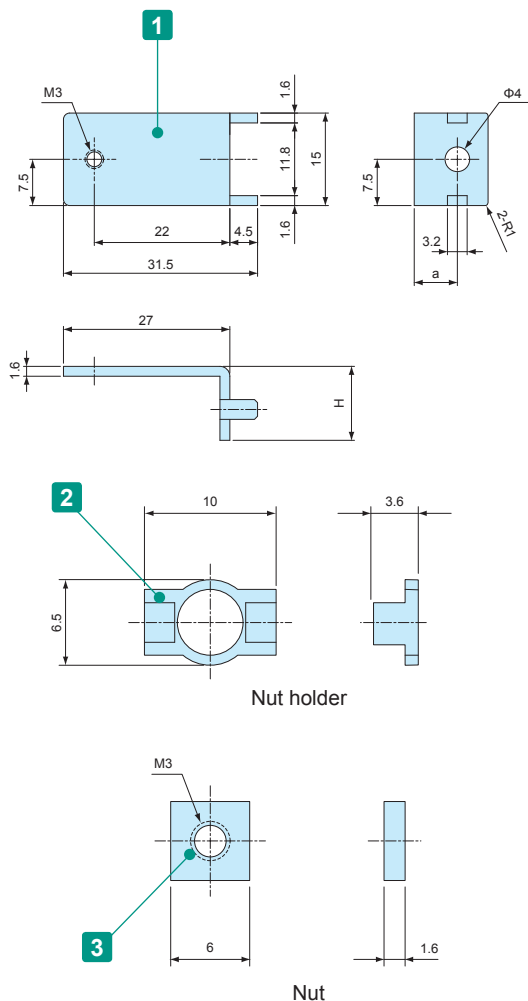

- 2 mounting brackets for PCB or DIN-Rail.
- FCK mounting bracket comes with FCC mounting plate.
Additional FCK is not necessary when purchasing FCC series.
- Not suitable for FC4 (H = 37.9mm).

Components

No.	Part name	Material	Color / Finish
1	Mounting bracket	Steel SECC t=1.6	Zinc coated
2	Nut holder	POM	Black
3	M3 nut	Steel SPCC t=1.6	Trivalent chromate

Product no. / Dimensions

Product no.	H	a	Pack of
FCK-1	12	7	10
FCK-2	22	17	10

Included screws: M3-6 pan head trivalent chromate with flat washer x 20 pcs