

FC SERIES ALUMINIUM CONTROL BOX

FC and FCW series are applicable for various purposes such as control and switch box, touch panel display, monitor box, and so on.

APPLICATION EXAMPLE

ULTRASONIC FLAW DETECTOR

Product by NOVOTEST (Ukraine)

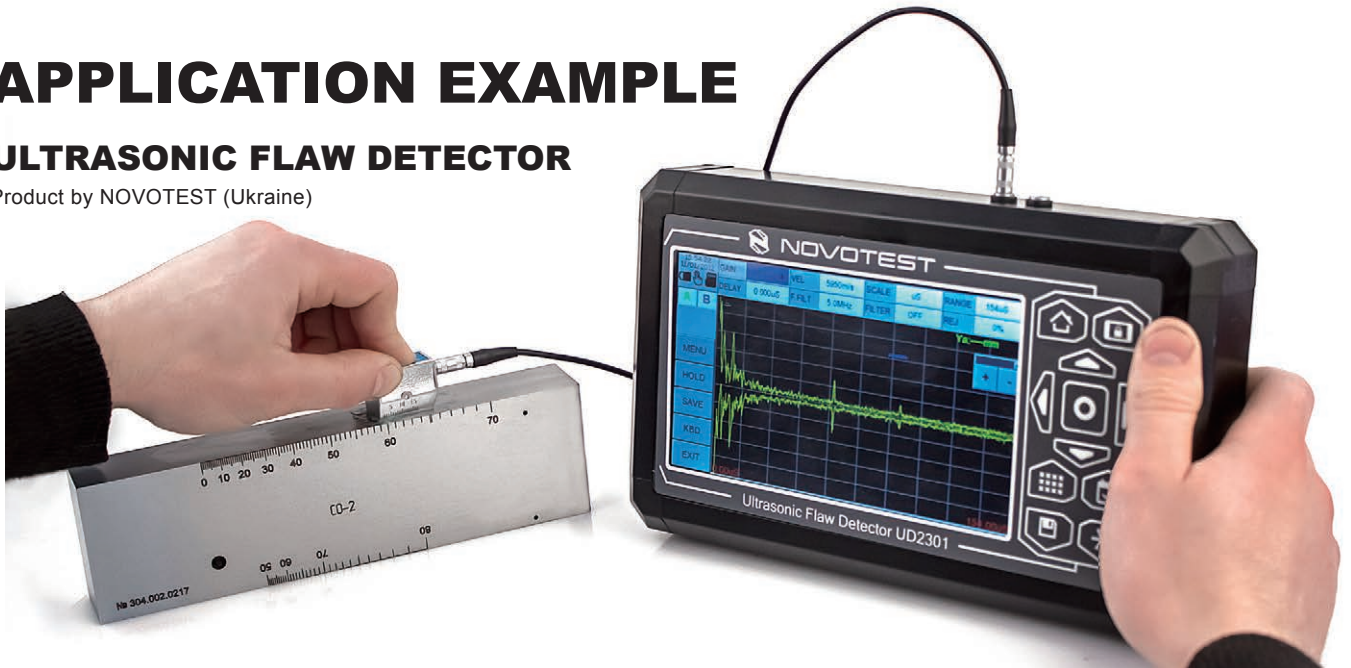

COIL WINDING MACHINE Product by TNK (Japan)



4-AXIS ROBOT CONTROLLER

Product by KDS (Japan)



STREAMING VIDEO PROVIDER



Product by StreamingVideoProvider (UK)

HAND-CARRY CONTROL BOX



Product by Coms (Japan)

SOLAR MONITORING SYSTEM

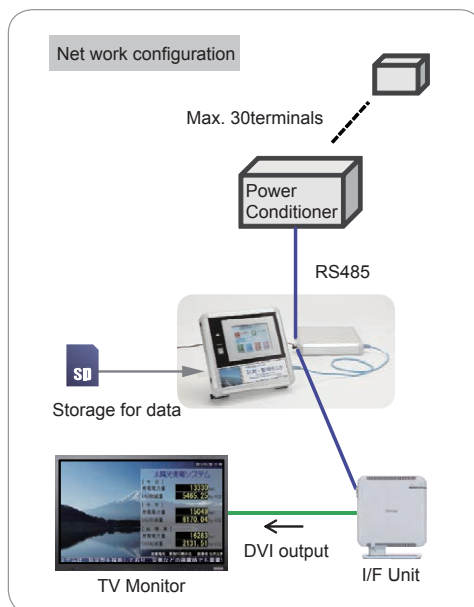
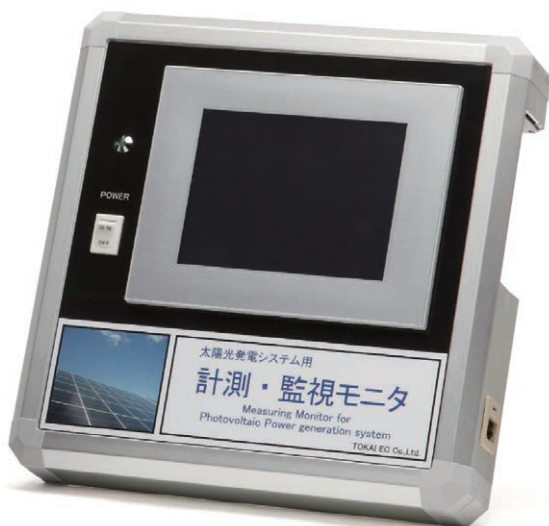

4 CHANNEL EDGE NODE

Product by SHINWA (Japan)



ACTIVE RFID TAG READER • TRIGGER

Product by Matrix (Japan)

Hands-free type



Touch type



COMPACT SOLAR POWER SUPPLY

Product by Elenagic (Japan)





Technical Data
Protection class: IP40

- 175 different sizes in 4 different color variations available.
- Simple designed aluminium utility box composed of extruded aluminium frames, aluminium panels and ABS corner joints.
- Suitable for touch panel display, industrial control equipment, and various other devices.

Custom width / length available in 1mm intervals

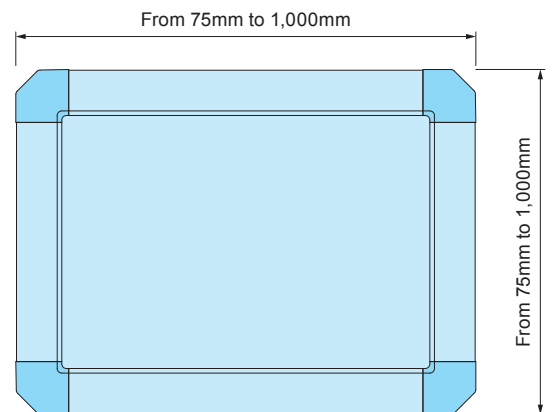

- Flexible frame width / length from 75mm to 1,000mm in 1mm intervals.
- No minimum order quantity and short lead time for small quantity order.

Assembly drawings

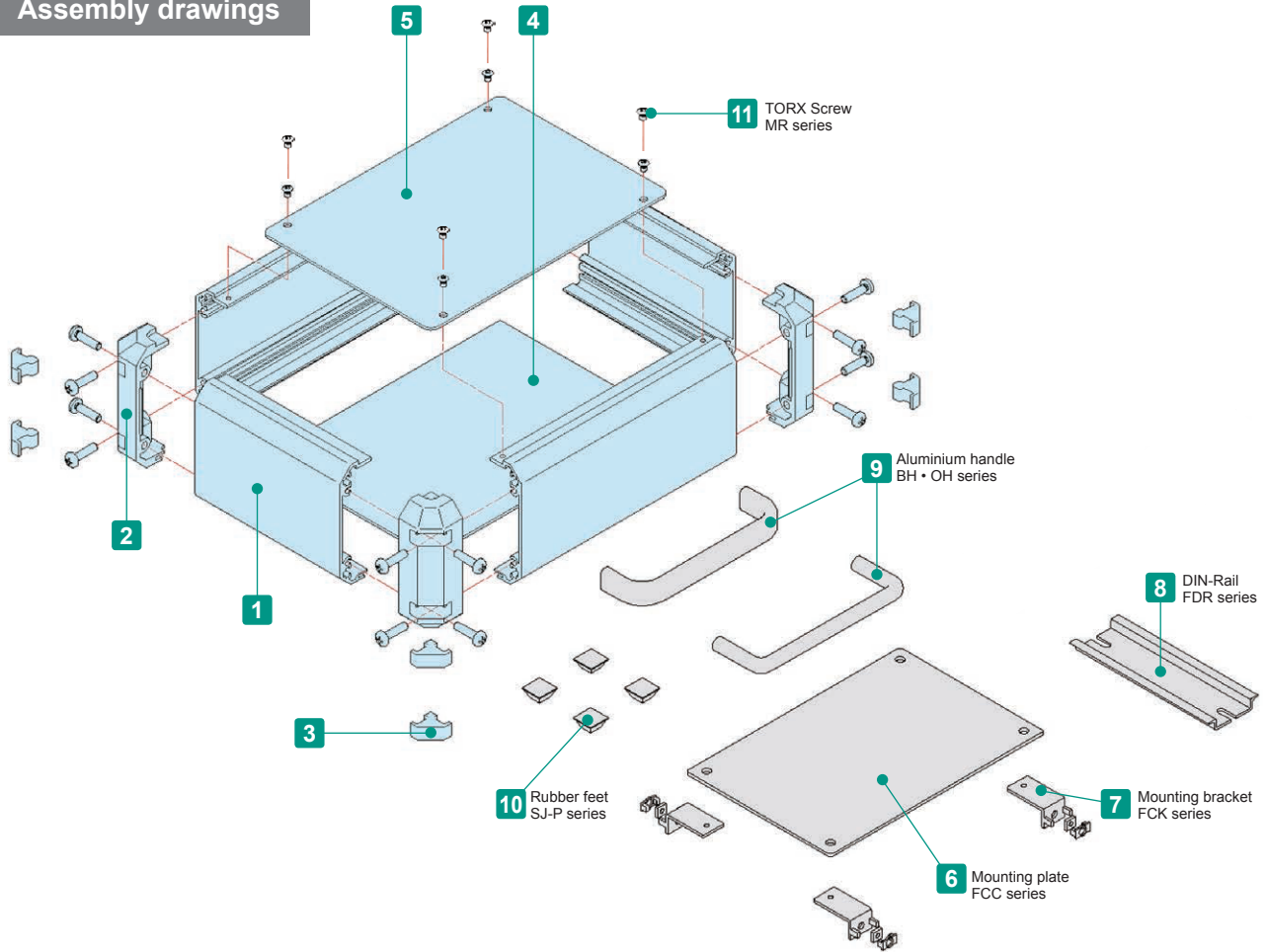

Included screws
M4-15 Trivalent chromate
(M3-15 for FC4 models)
M3-5 Slotted raised countersunk / Silver = Nickel plated, Black = Trivalent chromate

Components

No.	Part name	Pcs	Material	Color / Finish
1	Frame	4	Extruded aluminium A6063S-T5	Silver • Black / Anodized
2	Corner block	4	ABS UL94HB	Light gray • Black
3	Blind plug	8	TPE	Light gray • Black
4	Slide panel	1	Aluminium A1050P t=1.5	Silver / Hairline brushed & Anodized
			Aluminium A1100P t=1.5	Black / painted
5	Screwed panel	1	Aluminium A1050P t=1.5	Silver / Hairline brushed & Anodized
			Aluminium A1100P t=1.5	Black / painted

Accessories (Optional parts)



6 Mounting plate FCC series
See page FCC • FCK-1 ~ FCC • FCK-2

7 Mounting bracket FCK series
See page FCC • FCK-2

8 DIN-Rail FDR series
See MR • FDR-1

9 Aluminium handle BH • OH series
See page BH • Z-P-1 & OH • KH-1

10 Rubber feet SJ-P series
See page Feet-2



11 TORX screw MR3-5Z
See MR • FDR-1

FC dimensions

■ Drawings below are reference examples only.
DXF/DWG/PDF drawings available on our website.

FC4 models

■ Refer to page 211 ~ 212 for enclosure dimensions.

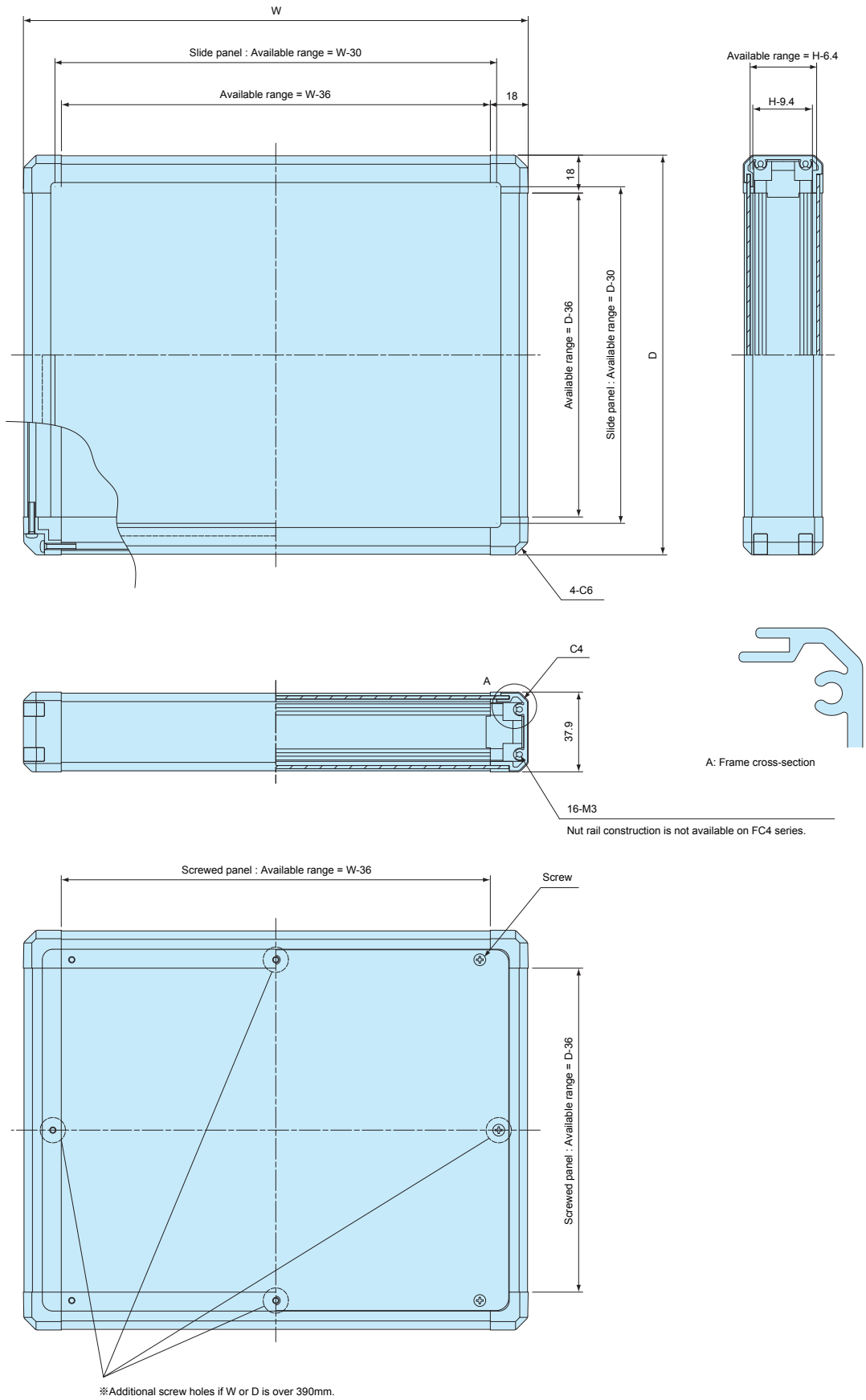

FC5 • FC6 • FC8 • FC10 • FC13 • FC15 models

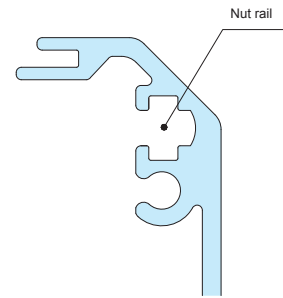
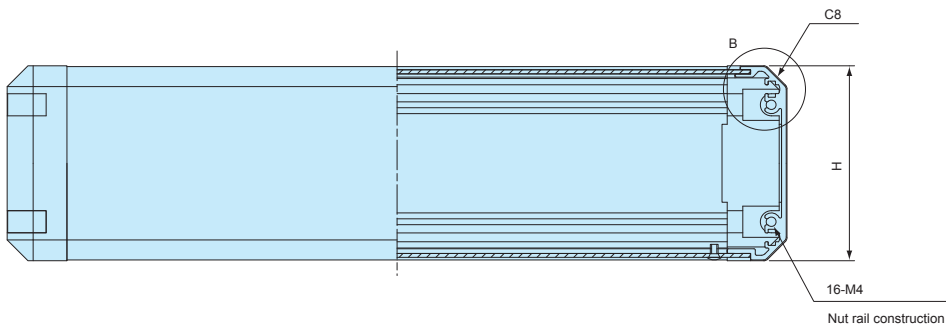
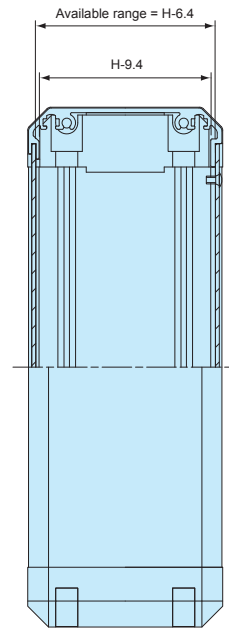
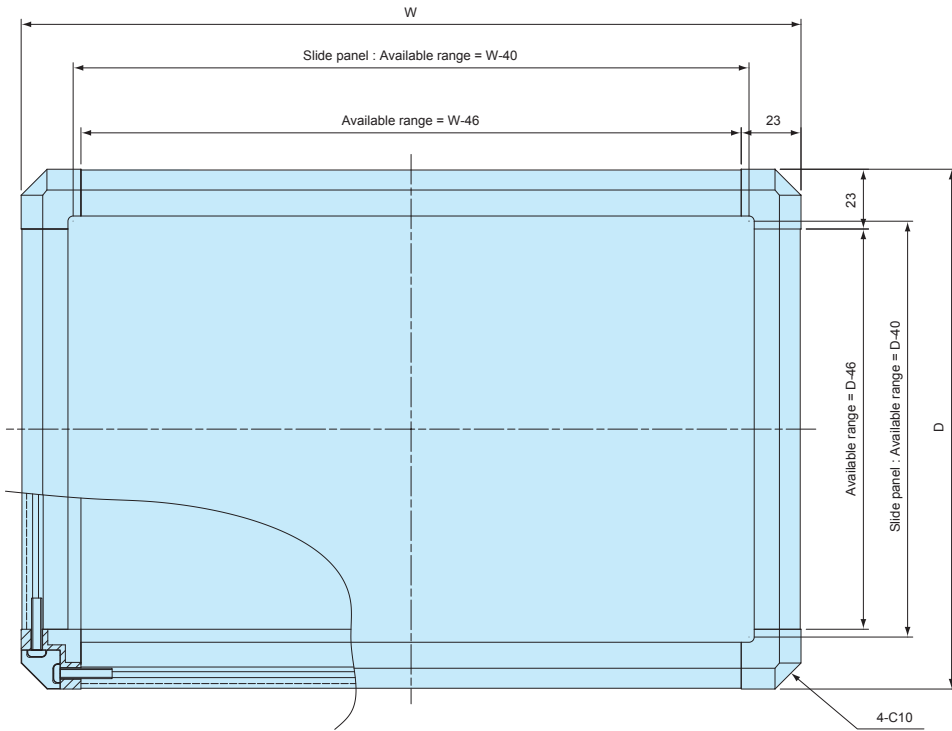



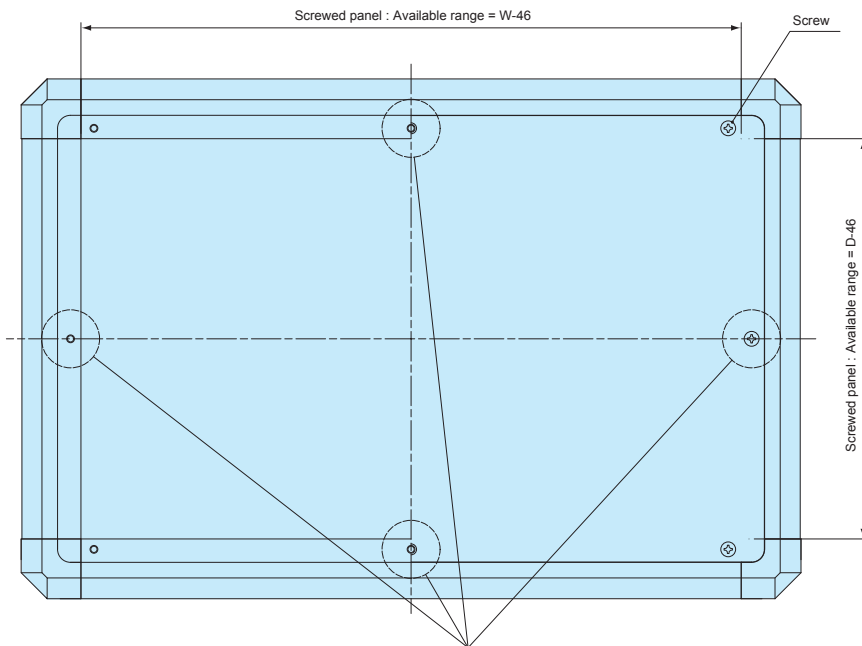

A: Frame cross-section



※ Additional screw holes if W or D is over 400mm.

Color Type

GS		BS		BX		BB	
							
Panel	Silver	Panel	Silver	Panel	Silver	Panel	Black
Frame	Silver	Frame	Silver	Frame	Black	Frame	Black
Corner	Light gray	Corner	Black	Corner	Black	Corner	Black

Product no. / Dimensions

■ Please suffix color code at the end of the product number.

Product no.	H	W	D	Weight (kg)	Panel mount screw pcs
FC4- 9- 9□	37.9	90	90	0.17	4
FC4-14- 9□	37.9	140	90	0.24	4
FC4-14-14□	37.9	140	140	0.33	4
FC4-19- 9□	37.9	190	90	0.31	4
FC4-19-14□	37.9	190	140	0.50	4
FC4-19-19□	37.9	190	190	0.53	4
FC4-24-14□	37.9	240	140	0.51	4
FC4-24-19□	37.9	240	190	0.64	4
FC4-24-24□	37.9	240	240	0.78	4
FC4-29-14□	37.9	290	140	0.60	4
FC4-29-19□	37.9	290	190	0.75	4
FC4-29-24□	37.9	290	240	0.91	4
FC4-29-29□	37.9	290	290	1.07	4
FC4-34-19□	37.9	340	190	0.87	4
FC4-34-24□	37.9	340	240	1.04	4
FC4-34-29□	37.9	340	290	0.94	4
FC4-39-19□	37.9	390	190	0.97	6
FC4-39-24□	37.9	390	240	1.17	6
FC4-39-29□	37.9	390	290	1.37	6
FC4-39-39□	37.9	390	390	1.77	8
FC4-49-24□	37.9	490	240	1.39	6
FC4-49-29□	37.9	490	290	1.64	6
FC4-49-39□	37.9	490	390	2.12	8
FC4-59-29□	37.9	590	290	1.92	6
FC4-59-39□	37.9	590	390	2.46	8
FC5-10-10□	50.4	100	100	0.24	4
FC5-15-10□	50.4	150	100	0.33	4
FC5-15-15□	50.4	150	150	0.44	4
FC5-20-10□	50.4	200	100	0.42	4
FC5-20-15□	50.4	200	150	0.55	4
FC5-20-20□	50.4	200	200	0.68	4
FC5-25-15□	50.4	250	150	0.66	4
FC5-25-20□	50.4	250	200	0.81	4
FC5-25-25□	50.4	250	250	0.97	4
FC5-30-15□	50.4	300	150	0.77	4
FC5-30-20□	50.4	300	200	0.94	4
FC5-30-25□	50.4	300	250	1.11	4
FC5-30-30□	50.4	300	300	1.29	4
FC5-35-20□	50.4	350	200	1.07	4
FC5-35-25□	50.4	350	250	1.26	4
FC5-35-30□	50.4	350	300	1.46	4
FC5-40-20□	50.4	400	200	1.20	6
FC5-40-25□	50.4	400	250	1.42	6
FC5-40-30□	50.4	400	300	1.64	6

Product no.	H	W	D	Weight (kg)	Panel mount screw pcs
FC5-40-40□	50.4	400	400	2.07	8
FC5-50-25□	50.4	500	250	1.66	6
FC5-50-30□	50.4	500	300	1.92	6
FC5-50-40□	50.4	500	400	2.44	8
FC5-60-30□	50.4	600	300	2.22	6
FC5-60-40□	50.4	600	400	2.81	8
FC6-10-10□	62.9	100	100	0.26	4
FC6-15-10□	62.9	150	100	0.35	4
FC6-15-15□	62.9	150	150	0.47	4
FC6-20-10□	62.9	200	100	0.45	4
FC6-20-15□	62.9	200	150	0.58	4
FC6-20-20□	62.9	200	200	0.72	4
FC6-25-15□	62.9	250	150	0.70	4
FC6-25-20□	62.9	250	200	0.85	4
FC6-25-25□	62.9	250	250	1.01	4
FC6-30-15□	62.9	300	150	0.81	4
FC6-30-20□	62.9	300	200	0.99	4
FC6-30-25□	62.9	300	250	1.16	4
FC6-30-30□	62.9	300	300	1.35	4
FC6-35-20□	62.9	350	200	1.12	4
FC6-35-25□	62.9	350	250	1.32	4
FC6-35-30□	62.9	350	300	1.52	4
FC6-40-20□	62.9	400	200	1.25	6
FC6-40-25□	62.9	400	250	1.47	6
FC6-40-30□	62.9	400	300	1.70	6
FC6-40-40□	62.9	400	400	2.15	8
FC6-50-25□	62.9	500	250	1.72	6
FC6-50-30□	62.9	500	300	1.99	6
FC6-50-40□	62.9	500	400	2.52	8
FC6-60-30□	62.9	600	300	2.29	6
FC6-60-40□	62.9	600	400	2.43	8
FC8-10-10□	75.4	100	100	0.28	4
FC8-15-10□	75.4	150	100	0.38	4
FC8-15-15□	75.4	150	150	0.50	4
FC8-20-10□	75.4	200	100	0.48	4
FC8-20-15□	75.4	200	150	0.62	4
FC8-20-20□	75.4	200	200	0.76	4
FC8-25-15□	75.4	250	150	0.74	4
FC8-25-20□	75.4	250	200	0.90	4
FC8-25-25□	75.4	250	250	1.07	4
FC8-30-15□	75.4	300	150	0.86	4
FC8-30-20□	75.4	300	200	1.04	4
FC8-30-25□	75.4	300	250	1.23	4
FC8-30-30□	75.4	300	300	1.42	4

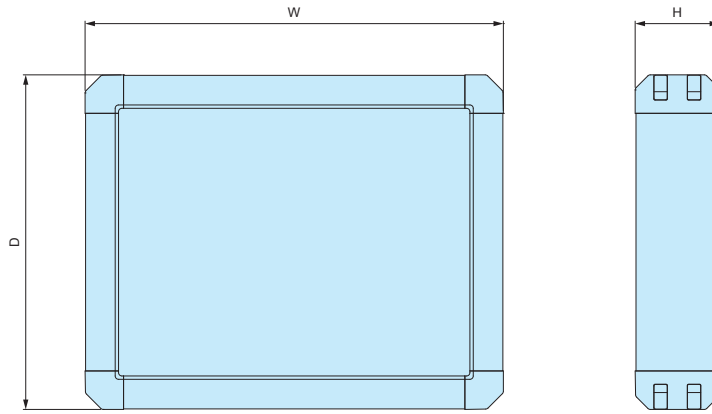

Product no.	H	W	D	Weight (kg)	Panel mount screw pcs
FC 8-35-20□	75.4	350	200	1.19	4
FC 8-35-25□	75.4	350	250	1.39	4
FC 8-35-30□	75.4	350	300	1.51	4
FC 8-40-20□	75.4	400	200	1.32	6
FC 8-40-25□	75.4	400	250	1.46	6
FC 8-40-30□	75.4	400	300	1.78	6
FC 8-40-40□	75.4	400	400	2.24	8
FC 8-50-25□	75.4	500	250	1.81	6
FC 8-50-30□	75.4	500	300	2.08	6
FC 8-50-40□	75.4	500	400	2.62	8
FC 8-60-30□	75.4	600	300	2.39	6
FC 8-60-40□	75.4	600	400	3.00	8
FC10-10-10□	100.4	100	100	0.31	4
FC10-15-10□	100.4	150	100	0.43	4
FC10-15-15□	100.4	150	150	0.56	4
FC10-20-10□	100.4	200	100	0.54	4
FC10-20-15□	100.4	200	150	0.70	4
FC10-20-20□	100.4	200	200	0.85	4
FC10-25-15□	100.4	250	150	0.83	4
FC10-25-20□	100.4	250	200	1.01	4
FC10-25-25□	100.4	250	250	1.19	4
FC10-30-15□	100.4	300	150	0.97	4
FC10-30-20□	100.4	300	200	1.16	4
FC10-30-25□	100.4	300	250	1.36	4
FC10-30-30□	100.4	300	300	1.57	4
FC10-35-20□	100.4	350	200	1.32	4
FC10-35-25□	100.4	350	250	1.54	4
FC10-35-30□	100.4	350	300	1.77	4
FC10-40-20□	100.4	400	200	1.47	6
FC10-40-25□	100.4	400	250	1.72	6
FC10-40-30□	100.4	400	300	1.96	6
FC10-40-40□	100.4	400	400	2.45	8
FC10-50-25□	100.4	500	250	1.99	6
FC10-50-30□	100.4	500	300	2.27	6
FC10-50-40□	100.4	500	400	2.84	8
FC10-60-30□	100.4	600	300	2.60	6
FC10-60-40□	100.4	600	400	2.70	8
FC13-10-10□	125.4	100	100	0.35	4
FC13-15-10□	125.4	150	100	0.47	4
FC13-15-15□	125.4	150	150	0.61	4
FC13-20-10□	125.4	200	100	0.59	4
FC13-20-15□	125.4	200	150	0.75	4
FC13-20-20□	125.4	200	200	0.92	4
FC13-25-15□	125.4	250	150	0.90	4

Product no.	H	W	D	Weight (kg)	Panel mount screw pcs
FC13-25-20□	125.4	250	200	1.08	4
FC13-25-25□	125.4	250	250	1.27	4
FC13-30-15□	125.4	300	150	1.04	4
FC13-30-20□	125.4	300	200	1.24	4
FC13-30-25□	125.4	300	250	1.44	4
FC13-30-30□	125.4	300	300	1.66	4
FC13-35-20□	125.4	350	200	1.40	4
FC13-35-25□	125.4	350	250	1.63	4
FC13-35-30□	125.4	350	300	1.86	4
FC13-40-20□	125.4	400	200	1.56	6
FC13-40-25□	125.4	400	250	1.81	6
FC13-40-30□	125.4	400	300	2.06	6
FC13-40-40□	125.4	400	400	2.56	8
FC13-50-25□	125.4	500	250	2.09	6
FC13-50-30□	125.4	500	300	2.38	6
FC13-50-40□	125.4	500	400	2.96	8
FC13-60-30□	125.4	600	300	2.89	6
FC13-60-40□	125.4	600	400	3.36	8
FC15-10-10□	150.4	100	100	0.40	4
FC15-15-10□	150.4	150	100	0.54	4
FC15-15-15□	150.4	150	150	0.70	4
FC15-20-10□	150.4	200	100	0.68	4
FC15-20-15□	150.4	200	150	0.85	4
FC15-20-20□	150.4	200	200	1.04	4
FC15-25-15□	150.4	250	150	1.02	4
FC15-25-20□	150.4	250	200	1.22	4
FC15-25-25□	150.4	250	250	1.42	4
FC15-30-15□	150.4	300	150	1.17	4
FC15-30-20□	150.4	300	200	1.40	4
FC15-30-25□	150.4	300	250	1.62	4
FC15-30-30□	150.4	300	300	1.85	4
FC15-35-20□	150.4	350	200	1.58	4
FC15-35-25□	150.4	350	250	1.82	4
FC15-35-30□	150.4	350	300	2.07	4
FC15-40-20□	150.4	400	200	1.76	6
FC15-40-25□	150.4	400	250	2.02	6
FC15-40-30□	150.4	400	300	2.29	6
FC15-40-40□	150.4	400	400	2.83	8
FC15-50-25□	150.4	500	250	2.32	6
FC15-50-30□	150.4	500	300	2.63	6
FC15-50-40□	150.4	500	400	3.25	8
FC15-60-30□	150.4	600	300	2.98	6
FC15-60-40□	150.4	600	400	3.66	8

FC • FCW cross-section view

■ Drawings below are reference examples only.
DXF/DWG/PDF drawings available on our website.

FC4 models

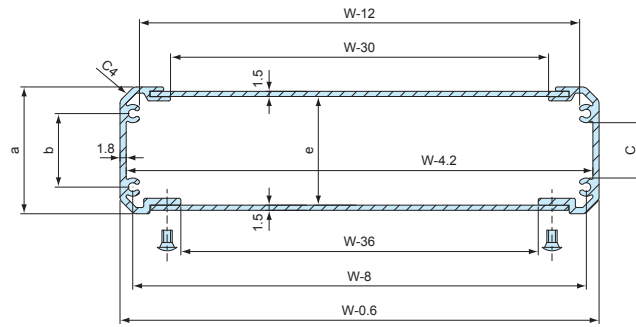

FC5 • FC6 • FC8 • FC10 • FC13 • FC15 models

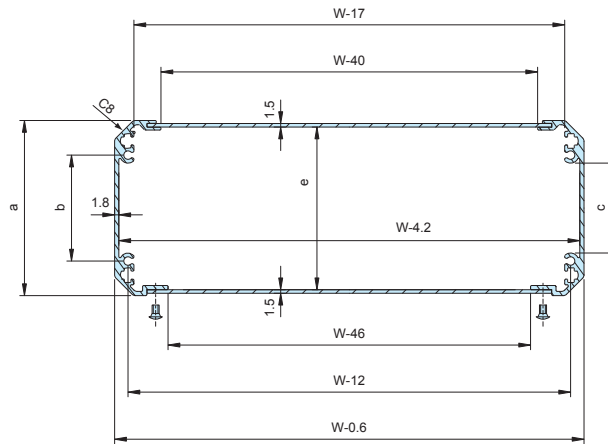

FCW series

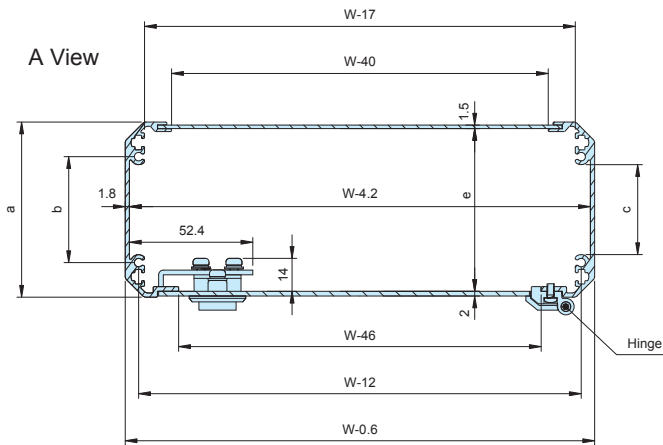

W Cross-section

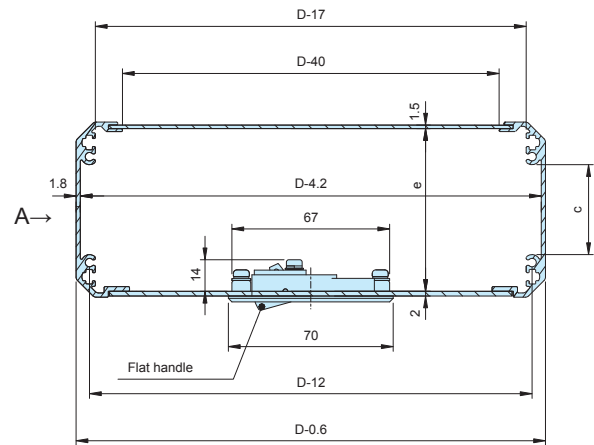

D cross-section

Box height	a	b	c	e
37.9	36.9	21.4	16.1	31.5
50.4	49.4	20	13.2	44
62.9	61.9	32.5	25.7	56.5
75.4	74.4	45	38.2	69
100.4	99.4	70	63.2	94
125.4	124.4	95	88.2	119
150.4	149.4	120	113.2	144

FC-BK SERIES BLIND PLUG

■ Spare / Replacement bling plug for FC • FCW series.

FC-BK-S□ (FC4 models) FC-BK-□ (Other FC models • FCW series)

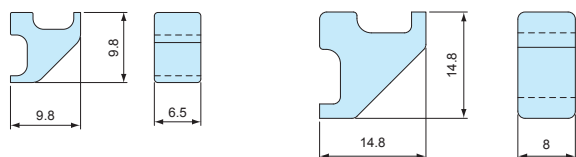

Product no.	Material	Color	Pack of
FC-BK-SG	TPE	Light gray	1 set (4 pcs)
FC-BK-SB	TPE	Black	1 set (4 pcs)
FC-BK-G	TPE	Light gray	1 set (4 pcs)
FC-BK-B	TPE	Black	1 set (4 pcs)

FW SERIES HINGE for FCW

■ Spare / Replacement hinge for FCW series.

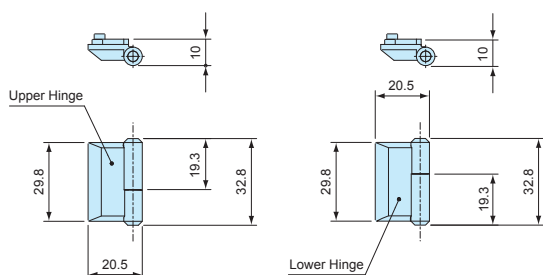

Product no.	Material	Color / Finish	Pack of
FW-2S	Diecast zinc	Silver / Painted	1 set (Upper/Lower)
FW-2B	Diecast zinc	Black / Painted	1 set (Upper/Lower)

PH-88 SERIES FLAT HANDLE for FCW

■ Spare / Replacement flat handle for FCW series.

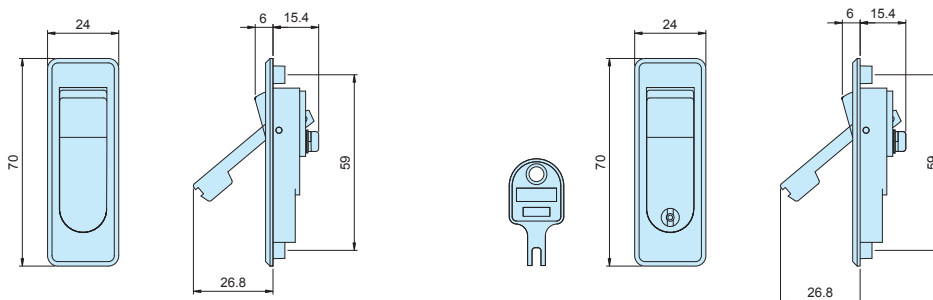

Normal type (without Key)

Key-lock type (with Key)

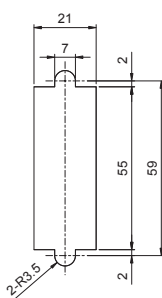

Mounting hole dimensions

Product no.	Key	Material	Color / Finish
PH-88A-2S	without	Diecast zinc	Silver / Painted
PH-88A-2B	without	Diecast zinc	Black / Painted
PH-88 -2S	with	Diecast zinc	Silver / Painted
PH-88 -2B	with	Diecast zinc	Black / Painted

FCC SERIES

MOUNTING PLATE for FC • FCW

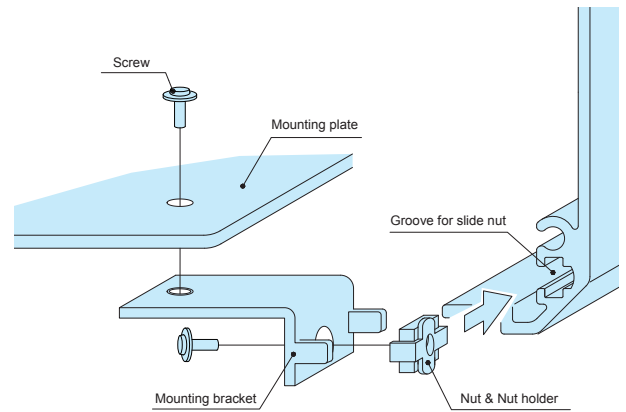
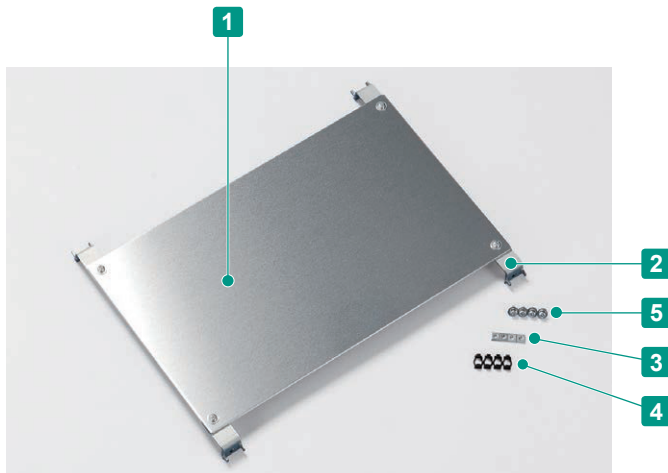

How to assemble

- ① Slide a M3 nut and nut holder into the groove on the frame.
- ② Screw the mounting bracket into the nut holder.
- ③ Screw the mounting plate onto the mounting bracket.

- The mounting bracket comes in 2 different height versions, 12mm and 22mm.
- Use 22mm height version when set on the open/close panel side of FCW series.
- Not suitable for FC4 (H = 37.9mm)
- Mounting brackets (FCK) are included with FCC series.
- DXF/DWG/PDF drawings available on our website.

Components

No.	Part name	Material	Color / Finish
1	Mounting plate	Aluminium A1050P t=2.0	Unfinished
2	Mounting bracket	Steel SECC t=1.6	Zinc coated
3	M3 nut	Steel SPCC t=1.6	Trivalent chromate
4	Nut holder	POM	Black
5	Screw	Steel M3-6	Trivalent chromate

For box size (W x D or D x W) 100 x 100mm to 350 x 300mm

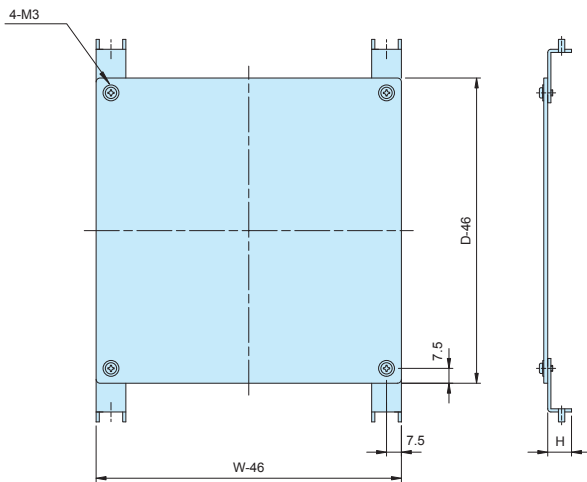

For box size (W x D or D x W) 400/500/600 x 200/250/300 mm

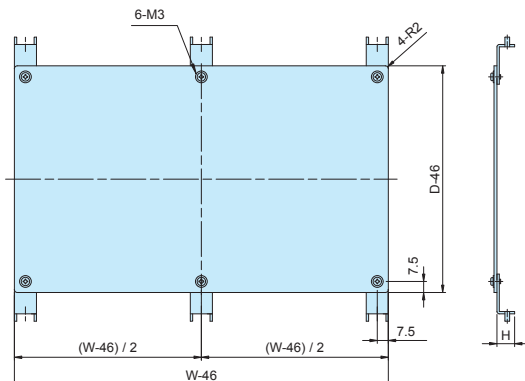

Product no. / Dimensions

Product no.	H	Box W x D or D x W	Product no.	H	Box W x D or D x W
FCC10-10-1	12	100×100	FCC10-10-2	22	100×100
FCC15-10-1	12	150×100	FCC15-10-2	22	150×100
FCC15-15-1	12	150×150	FCC15-15-2	22	150×150
FCC20-10-1	12	200×100	FCC20-10-2	22	200×100
FCC20-15-1	12	200×150	FCC20-15-2	22	200×150
FCC20-20-1	12	200×200	FCC20-20-2	22	200×200
FCC25-15-1	12	250×150	FCC25-15-2	22	250×150
FCC25-20-1	12	250×200	FCC25-20-2	22	250×200
FCC25-25-1	12	250×250	FCC25-25-2	22	250×250
FCC30-15-1	12	300×150	FCC30-15-2	22	300×150
FCC30-20-1	12	300×200	FCC30-20-2	22	300×200
FCC30-25-1	12	300×250	FCC30-25-2	22	300×250
FCC30-30-1	12	300×300	FCC30-30-2	22	300×300
FCC35-20-1	12	350×200	FCC35-20-2	22	350×200
FCC35-25-1	12	350×250	FCC35-25-2	22	350×250
FCC35-30-1	12	350×300	FCC35-30-2	22	350×300

Included screws: M3-6 pan head trivalent chromate with flat washer x 8 pcs

Product no. / Dimensions

Product no.	H	Box W x D or D x W	Product no.	H	Box W x D or D x W
FCC40-20-1	12	400×200	FCC40-20-2	22	400×200
FCC40-25-1	12	400×250	FCC40-25-2	22	400×250
FCC40-30-1	12	400×300	FCC40-30-2	22	400×300
FCC50-25-1	12	500×250	FCC50-25-2	22	500×250
FCC50-30-1	12	500×300	FCC50-30-2	22	500×300
FCC60-30-1	12	600×300	FCC60-30-2	22	600×300

Included screws: M3-6 pan head trivalent chromate with flat washer x 12 pcs

For box size (W x D or D x W) 400/500/600 x 400mm

■ DXF/DWG/PDF drawings available on our website.

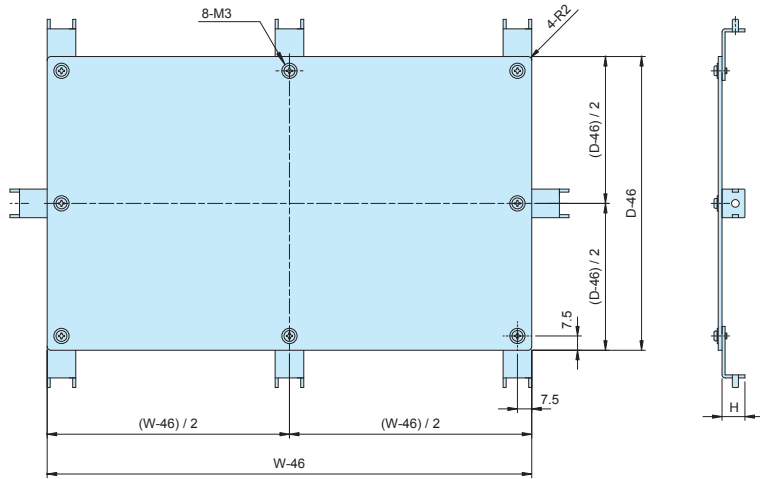

Product no. / Dimensions

Product no.	H	Box W x D or D x W	Product no.	H	Box W x D or D x W
FCC40-40-1	12	400x400	FCC40-40-2	22	400x400
FCC50-40-1	12	500x400	FCC50-40-2	22	500x400
FCC60-40-1	12	600x400	FCC60-40-2	22	600x400

Included screws: M3-6 pan head trivalent chromate with flat washer x 16 pcs

Accessories (Optional parts)

FCK SERIES MOUNTING BRACKET

■ DXF/DWG/PDF drawings available on our website.

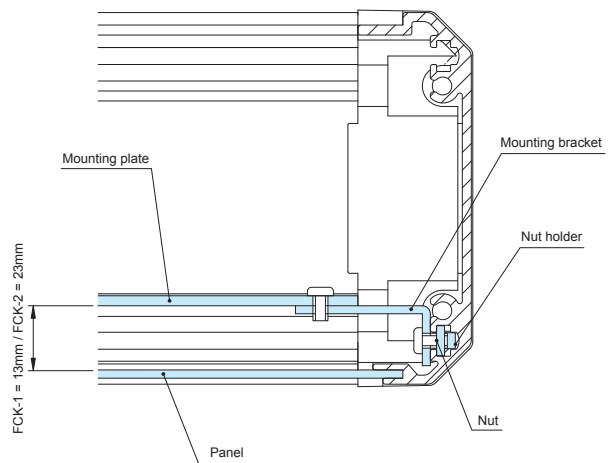
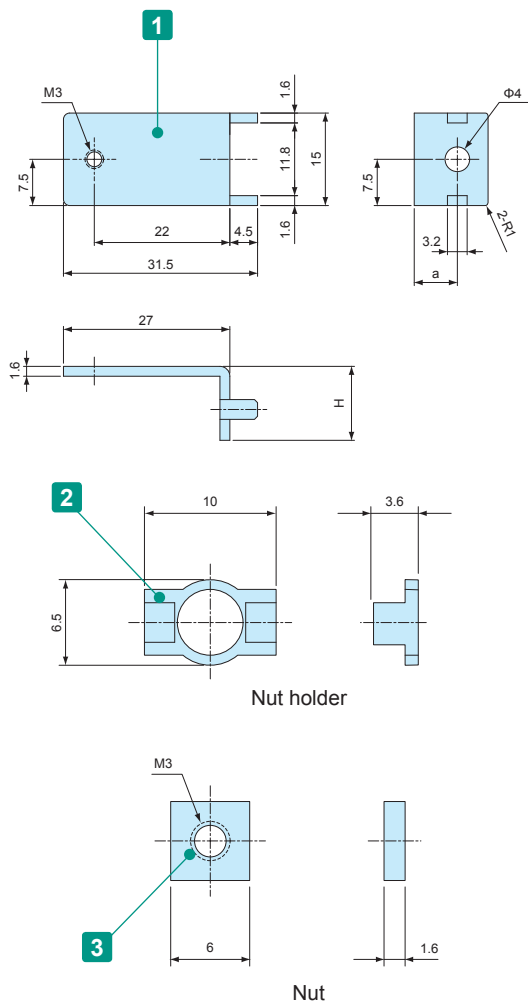

- 2 mounting brackets for PCB or DIN-Rail.
- FCK mounting bracket comes with FCC mounting plate. Additional FCK is not necessary when purchasing FCC series.
- Not suitable for FC4 (H = 37.9mm).

Components

No.	Part name	Material	Color / Finish
1	Mounting bracket	Steel SECC t=1.6	Zinc coated
2	Nut holder	POM	Black
3	M3 nut	Steel SPCC t=1.6	Trivalent chromate

Product no. / Dimensions

Product no.	H	a	Pack of
FCK-1	12	7	10
FCK-2	22	17	10

Included screws: M3-6 pan head trivalent chromate with flat washer x 20 pcs

MR SERIES

SLOTTED RAISED COUNTERSUNK TORX SCREW



- For use with top / bottom cover.
- Recommended for aesthetic purposes, or for tampering resistance.
- Requires the use of a specialized screwdriver.

Product no. / Dimensions

Product no.	M	L	TORX head no.	Material	Color / Finish	Pack of
MR3-5ZS	3	5	T10	Steel	Nickel plated	20
MR3-5ZB	3	5	T10	Steel	Black trivalent chromate	20

FDR SERIES

DIN-RAIL

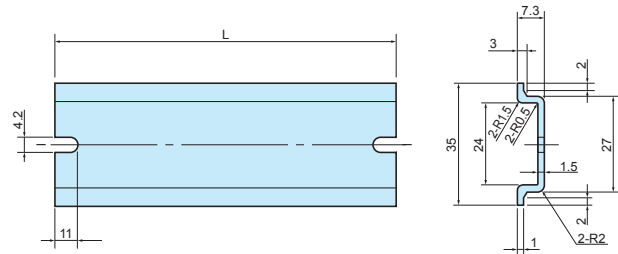
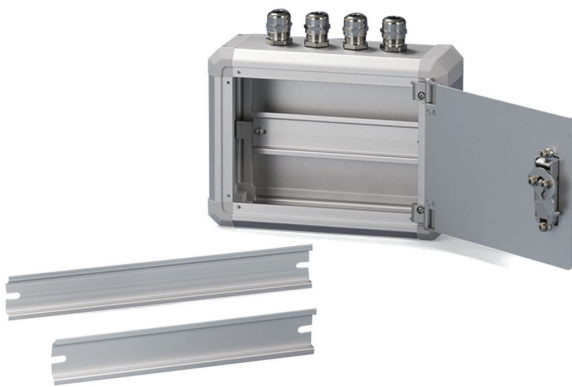

Components

Material	Color / Finish
Aluminium A6063S-T5	Silver / Anodized

Product no. / Dimensions

Product no.	L	Box length
FDR- 50	50	100
FDR-100	100	150
FDR-150	150	200
FDR-205	205	250
FDR-249	249	300
FDR-300	300	350
FDR-350	350	400
FDR-450	450	500
FDR-550	550	600

- FCK mounting bracket is required for installation.
- Not suitable for FC4 (H = 37.9mm).

BH SERIES ROUNDED ALUMINIUM HANDLE

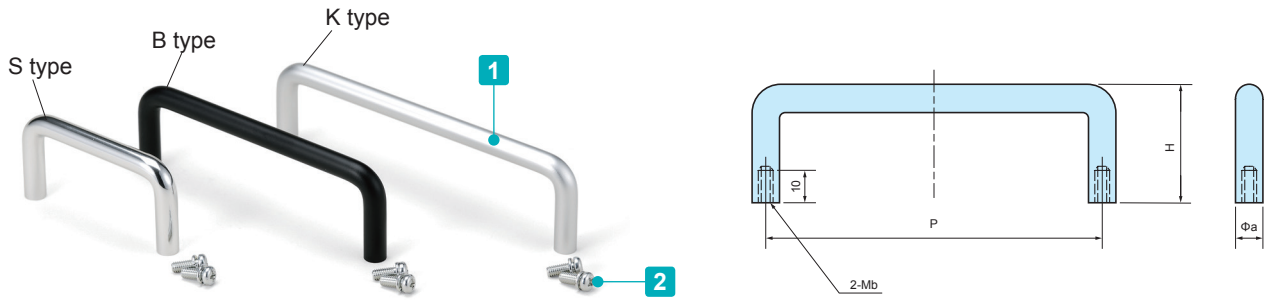

Components

No.	Part name	Pcs	Material	Color / Finish
1	Handle	1	Extruded aluminium A5056S	Polished • Matte anodized
2	Screw	2	Steel	Trivalent chromate

Product no. / Dimensions

■ K type only available on BH-100, 120, 150, and 180 models.

Product no.			P	H	a	b	Pack of
● Silver polished	● Black matte anodized	● Silver matte anodized					
BH- 26S	BH- 26B	-	26	25	6	3	2
BH- 30S	BH- 30B	-	30	35	8	4	2
BH- 50S	BH- 50B	-	50	35	8	4	2
BH- 60S	BH- 60B	-	60	35	8	4	2
BH- 70S	BH- 70B	-	70	35	8	4	2
BH- 80S	BH- 80B	-	80	35	8	4	2
BH-100S	BH-100B	BH-100K	100	35	8	4	2
BH-110S	BH-110B	-	110	35	8	4	2
BH-120S	BH-120B	BH-120K	120	35	8	4	2
BH-150S	BH-150B	BH-150K	150	35	8	4	2
BH-180S	BH-180B	BH-180K	180	35	8	4	2

Z-P SERIES WASHER for HANDLE

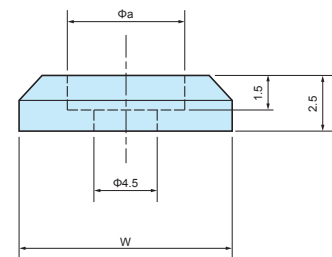
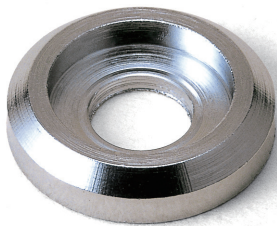

■ Brass washer for BH • KH series.

Product no. / Dimensions

■ Material / Brass

Product no.		W	a	Pack of
Chrome plated	Black painted			
Z-P6S	Z-P6B	10	6.2	10
Z-P8S	Z-P8B	12	8.2	10

OH SERIES ALUMINIUM HANDLE

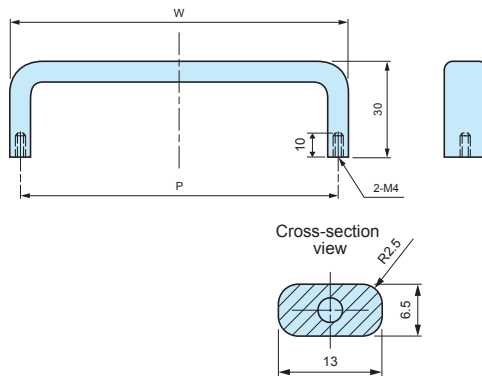
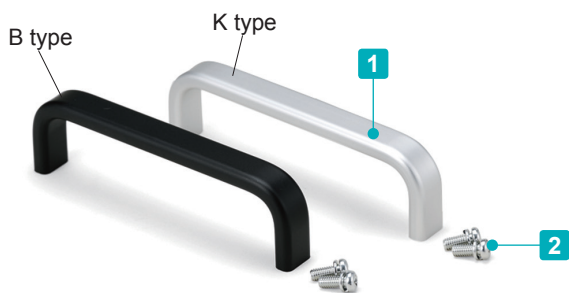

Components

No.	Part name	Pcs	Material	Color / Finish
1	Handle	1	Extruded aluminium A6063S-T5	Matte anodized
2	Screw (M4-10 Pan head with spring washer)	2	Steel	Trivalent chromate

Product no. / Dimensions

Product no.		P	W	Pack of
● Black matte anodized	● Silver matte anodized			
OH- 55B	OH- 55K	55	61.5	2
OH- 70B	OH- 70K	70	76.5	2
OH- 85B	OH- 85K	85	91.5	2
OH-100B	OH-100K	100	106.5	2
OH-120B	OH-120K	120	126.5	2
OH-140B	OH-140K	140	146.5	2
OH-170B	OH-170K	170	176.5	2

KH SERIES ANGLED ALUMINIUM HANDLE

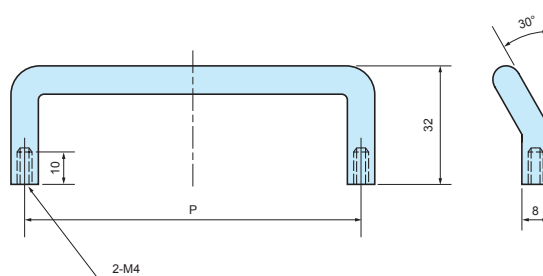

Components

No.	Part name	Pcs	Material	Color / Finish
1	Handle	1	Extruded aluminium A5056S	Polished • Matte anodized
2	Screw (M4-10 Pan head with spring washer)	2	Steel	Trivalent chromate

Product no. / Dimensions

Product no.		P	Pack of
● Silver polished	● Black matte anodized		
KH- 70S	KH- 70B	70	2
KH-100S	KH-100B	100	2

B SERIES ADHESIVE RUBBER FEET

DXF/DWG/PDF drawings available on our website.

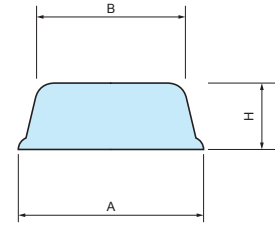

Injection molded type.

Product no. / Dimensions

Material : Synthetic rubber

Product no.	A	B	H	Color	Pack of
B 6-2	6	5	1.8	Black	10
B 8-4	8	7.7	3.5	Black	10
B10-4	10	9.2	4.2	Black	10
B11-3	10.8	10.2	3	Black	10
B11-5	11	9.6	5	Black	10
B12-4	12.7	10	3.8	Black	10
B15-5	15.4	14.8	5.1	Black	10
B16-7	16	13	7	Black	10
B19-4	19	15.8	4.2	Black	10
B21-7	21	17	7	Black	10
B23-5	22.8	22.4	5	Black	10
B26-11	26	20	11	Black	10
B 6-2G	6	5	1.8	Gray	10
B11-3G	10.8	10.2	3	Gray	10
B15-5G	15.4	14.8	5.1	Gray	10
B21-7G	21	17	7	Gray	10
B26-11G	26	20	11	Gray	10

B-P SERIES ADHESIVE RUBBER FEET

DXF/DWG/PDF drawings available on our website.

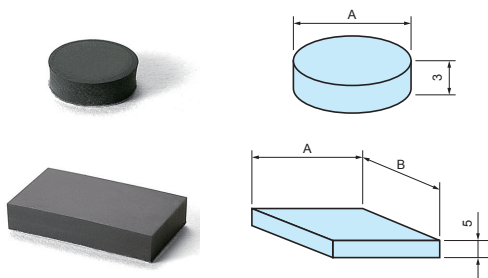

Press-punched type.

Product no. / Dimensions

Material / Color : Synthetic rubber / Black

Product no.	A	Pack of
B-P21	10	10
B-P22	20	10
B-P23	15	10

Product no. / Dimensions

Material / Color : Synthetic rubber / Black

Product no.	A	B	Pack of
B-P31	28	16	10
B-P32	46	26	10

TB SERIES ROUNDED ADHESIVE RUBBER FEET



DXF/DWG/PDF drawings available on our website.

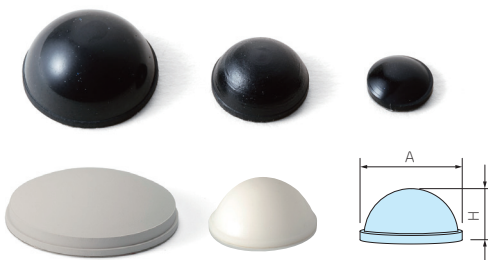

Product no. / Dimensions

Material : Synthetic rubber

Product no.	Product no.		A	H	Pack of
	● Black	● White (W) ● White gray (G)			
TB- 7	-	-	6.7	4.2	10
TB- 8	NEW TB- 8W	-	8	2.6	10
TB-10	-	-	10	2.8	10
TB-12	NEW TB-12W	-	11.3	5.6	10
TB-14	-	-	14	8	10
TB-16	NEW TB-16W	-	15.9	8	10
TB-21	-	-	21.6	8.5	10
TB-27	TB-27G	-	27.8	7.4	10

SF SERIES

SQUARE ADHESIVE RUBBER FEET - LOW COST TYPE

■ DXF/DWG/PDF drawings available on our website.

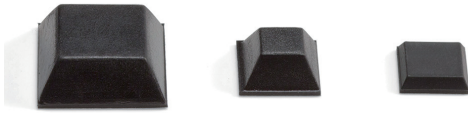

■ Square-shaped adhesive rubber feet.

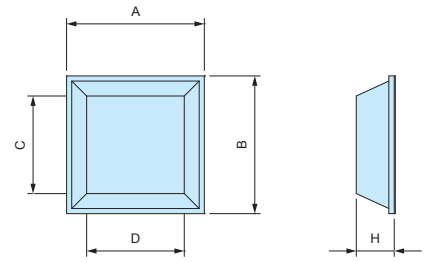

Product no. / Dimensions ■ Material / Color : Synthetic rubber / Black

Product no.	A	B	H	C	D	Pack of
SF11-3	10.5	10.5	2.5	8.6	8.6	10
SF13-4	12.7	12.7	3.5	9	9	10
SF13-6	12.7	12.7	6	7	7	10
SF20-8	20	20	7.6	14	14	10

SJ-P SERIES

SQUARE ADHESIVE POLYURETHANE FEET

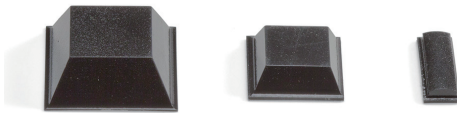

■ Strong adhesive strength with the use of rubber pressure sensitive adhesive.
 ■ Polyurethane material is resistant against color migration.

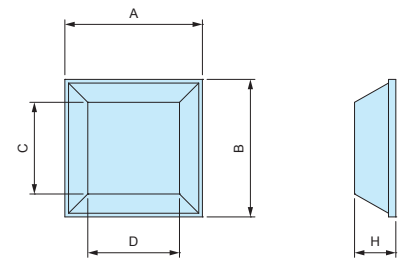

Product no. / Dimensions ■ Material / Color : Polyurethane / Black

Product no.	A	B	H	C	D	Pack of
SJ-P5007	10.4	10.4	2.5	7.5	7.5	10
SJ-P5008	12.7	12.7	3	9.5	9.5	10
SJ-P5018	12.7	12.7	5.8	7	7	10
SJ-P1004	15	15	4.5	10	10	10
SJ-P5023	20.6	20.6	7.6	12.7	12.7	10
SJ-P1011	15.5	5.5	2	4.5	14.5	10

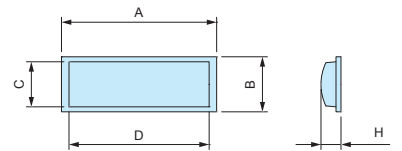

SJ-P1011

TN-27

OVAL ADHESIVE RUBBER FEET

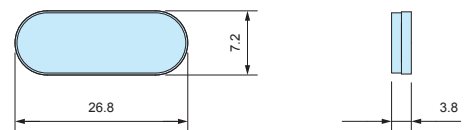
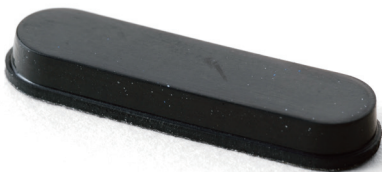

Product no. / Feature ■ Material / Color : Synthetic rubber / Black

Product no.	Pack of
TN-27	10

B-P SERIES

SCREW MOUNT RUBBER FEET

■ DXF/DWG/PDF drawings available on our website.



- Built-in washer and non-washer types are available.
- Installation screws are separately sold.

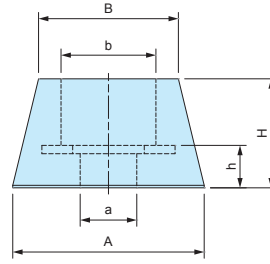

B-P1S, P1M, P1L, P2S, P4, P5

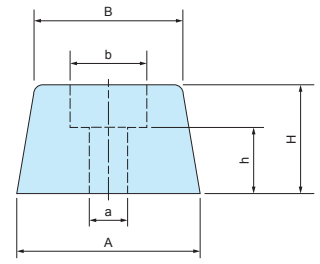

B-P1, P2, P3

Product no. / Dimensions

■ Color : Black

Product no.	A	B	H	a	b	h	Washer	Material	Pack of
B-P1S	11.5	8.4	7.2	3.4	5.7	3.2	○	Synthetic rubber	10
B-P1M	15	15	4	3.5	7.4	2.2	○	Synthetic rubber	10
B-P1	15	13	7.7	3	6	4.2	×	Synthetic rubber	10
B-P1L	16	13	7.8	3	6	3.7	○	Synthetic rubber	10
B-P2S	18	15	11	3	6	5	○	Synthetic rubber	10
B-P2	19	15	8	3	6	4.5	×	Synthetic rubber	10
B-P3	22	18	13	3	7.5	7	×	Synthetic rubber	10
B-P4	32	26	20	5	15	10	○	EPDM	10
B-P5	32	28	15	5	14	10	○	EPDM	10

B-P SERIES

SNAP-IN RUBBER FEET

■ DXF/DWG/PDF drawings available on our website.



- Hole milling required for installation.

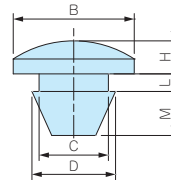

B-P10

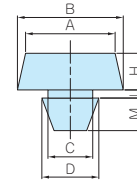

B-P10S, P11, P12

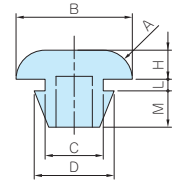

B-P13, P14, P15

Product no. / Dimensions

Product no.	A	B	H	C	D	L	M	Material	Color	Pack of
B-P10S	8	8	2	5	5.6	0.9	3	Silicone UL94V-0	Black	10
B-P10	—	11	3	6.3	7.6	1.6	4	Silicone UL94V-0	Black	10
B-P11	11	13	4.5	5.5	7	1	4	Synthetic rubber	Black	10
B-P12	15	17	4.5	5.5	7	1	4	Synthetic rubber	Black	10
B-P13	R3	12	3	5	7	1.6	4	EPDM	Black	10
B-P14	R4	14	4	6	9	1.6	5	EPDM	Black	10
B-P15	R4	16	4	8	11	1.6	5	EPDM	Black	10

A-P SERIES

SCREW MOUNT ELASTOMER FEET

■ DXF/DWG/PDF drawings available on our website.

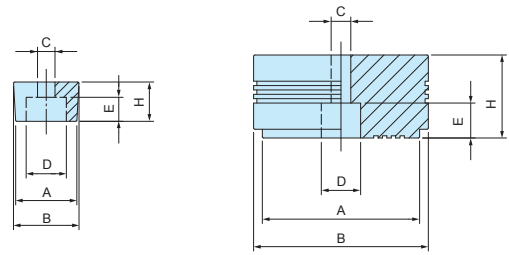

A-P1 ~ A-P5

A-P6

- Prepare screws for installation.
- Resistant against color migration.

Product no. / Dimensions

■ Material / Color : Elastomer / Black

Product no.	A	B	H	C	D	E	Pack of
A-P1	9.4	10.8	4	3.3	6.8	2	10
A-P2	13.4	14.2	5.5	3	8	3.5	10
A-P3	14	15	9	4	9.5	6	10
A-P4	20	21	8	4	8.2	5	10
A-P5	20	24	14	5.5	8.6	8	10
A-P6	36	40	19	4.5	9	7.5	10

TP SERIES

SNAP-IN ELASTOMER FEET

■ DXF/DWG/PDF drawings available on our website.

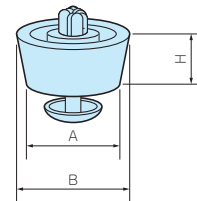

- Easy installation with snap-in pin.
- Require a hole for installation.
- Resistant against color migration.

Product no. / Dimensions

■ Material / Color : (Feet) LDPE • (PIN) PP / Black

Product no.	A	B	H	Mounting hole	Panel thickness	Pack of
TP-1	12	12.7	4.4	5	1.0 ~ 2.0	10
TP-2	15	15.7	4.4	5	1.0 ~ 2.0	10
TP-3	17.2	19.2	7.9	8	0.8 ~ 1.2	10
TP-4	18	20	10	8	1.0 ~ 2.5	10
TP-5	19.8	20.8	6.4	8	1.0 ~ 2.5	10
TP-6	19.5	23.7	13.7	8	1.0 ~ 2.5	10
TP-7	26.5	29.4	15	10	1.0 ~ 3.5	10

TM SERIES

PLASTIC FEET

■ DXF/DWG/PDF drawings available on our website.

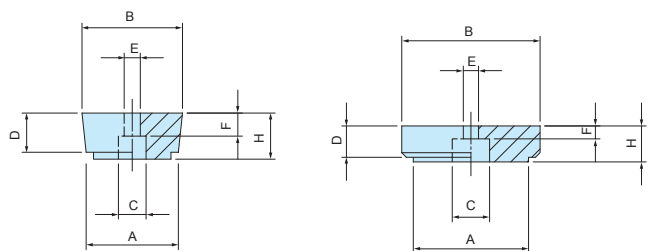
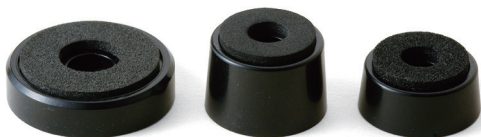

TM-1, TM-2

TM-1S, TM-3

- Plastic feet equipped with soft padding on the bottom to prevent sliding.

Product no. / Dimensions

Product no.	A	B	H	C	D	E	F	Feet material	Pad material	Color	Pack of
TM-1S	15.9	19.5	6.3	7	5.8	4	2.3	ABS UL94HB	Silicone	Black	10
TM-1	20	21.8	10	7.2	8.5	3.5	4.5	ABS UL94HB	EVA	Black	10
TM-2	20	21.8	15	7.2	13.5	3.5	4.5	ABS UL94HB	EVA	Black	10
TM-3	25	30	7.8	8.1	6.8	3.3	2.7	ABS UL94HB	EVA	Black	10