

BMP-Z SERIES

STEEL MOUNTING PLATE

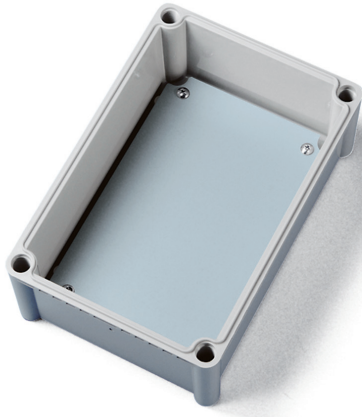

DXF/DWG/PDF drawings available on our website.

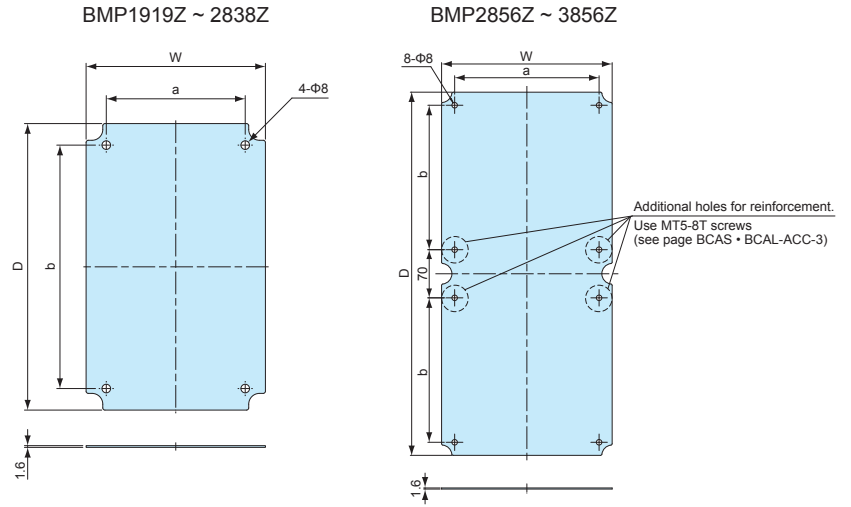

- Strong but easily customizable.
- Material/Finish : Steel t=1.6mm / Zinc coated

Product no. / Dimensions

Product no.	W	D	a	b	Suitable box	Weight (g)
BMP1919Z	159	159	120	120	BCAL191913	303
BMP1928Z	157	247	120	210	BCAL192813, 192818	462.5
BMP1938Z	159	347	120	310	BCAL193813, 193818	676.5
BMP2828Z	246	246	210	210	BCAL282813	727.5
BMP2834Z	246	306	210	270	BCAL283413	920
BMP2838Z	246	346	210	310	BCAL283813, 283818	1,018
BMP2856Z	248	528	210	210	BCAL285613	1,571
BMP3856Z	348	528	310	210	BCAL385618	2,210

BMP-P SERIES

PLASTIC MOUNTING PLATE

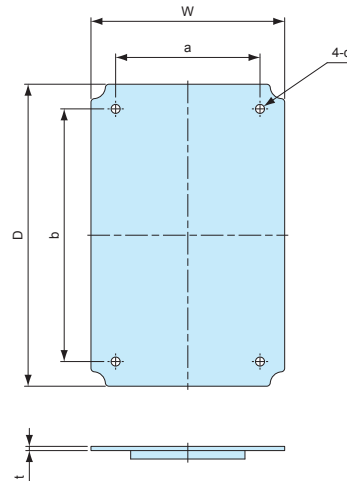
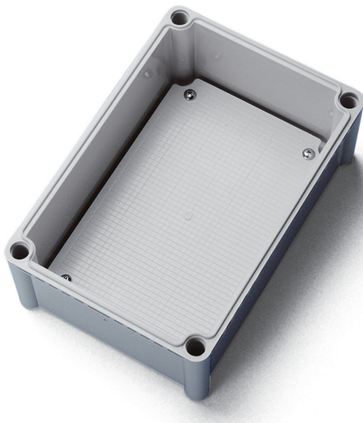

- Not available for BCAL283413, 285613, and 385618 models.
- Material/Color : ABS / White gray

Product no. / Dimensions

Product no.	W	D	a	b	c (Φ)	t	Suitable box	Weight (g)
BMP1919P	159	159	120	120	Φ8	4	BCAL191913	104
BMP1928P	158.5	248	120	210	Φ8	3.5	BCAL192813, 192818	162
BMP1938P	159	348	120	310	Φ8	4.5	BCAL193813, 193818	236
BMP2828P	248.5	248.5	210	210	Φ8	4	BCAL282813	237
BMP2838P	248	347.5	209	309.5	Φ8	4	BCAL283813, 283818	368