

T-600

M3 INSERT NUT ADHESIVE STANDOFF

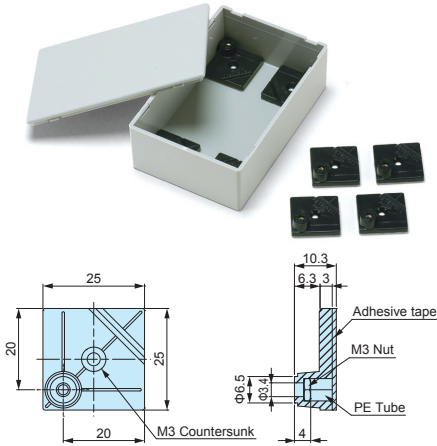

- Double-sided adhesive tape allows the standoff to be mounted easily; allows PCB mounting in non-boss enclosures.

NOTE

- Please ensure the surface is cleaned and grease-free before adhering.
- Once removed, it cannot be adhered on again.
- Recommended screw torque: 4kgf • cm (0.4N • m).

Product no. / Dimensions

Product no.	Material	Color	Weight (g)	Pack of
T-600	ABS	Black	2.6 (g) / pc	10

T-700

M4 INSERT NUT ADHESIVE STANDOFF

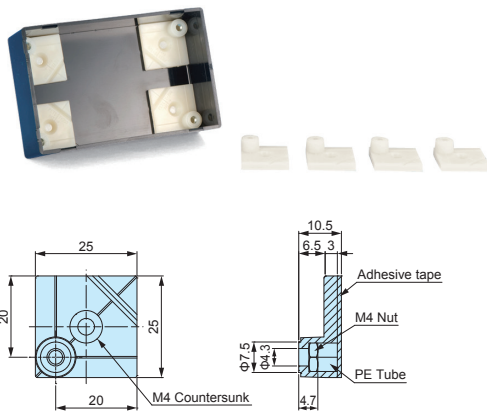

- Double-sided adhesive tape allows the standoff to be mounted easily; allows PCB mounting in non-boss enclosures.

NOTE

- Please ensure the surface is cleaned and grease-free before adhering.
- Once removed, it cannot be adhered on again.
- Recommended screw torque: 8.1kgf • cm (0.81N • m).

Product no. / Dimensions

Product no.	Material	Color	Weight (g)	Pack of
T-700	ABS	Natural	2.6 (g) / pc	10

ASR SERIES

ADHESIVE STANDOFF

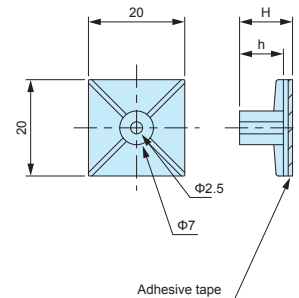

- M3 tapping screw use adhesive standoff. Recommended to be used with EM-3 or EM-3-6 tapping screws (See page EM • MR-1).

NOTE

- Please ensure the surface is cleaned and grease-free before adhering.
- Once removed, it cannot be adhered on again.
- Recommended screw torque: 4kgf • cm (0.4N • m).

Product no. / Dimensions

Product no.	H	h	Weight (g)	Pack of
ASR- 5	5.1	3.1	0.9 (g) / pc	10
ASR- 6	6.4	4.4	1.0 (g) / pc	10
ASR- 7	7.2	5.1	0.9 (g) / pc	10
ASR- 8	8.1	6.3	0.9 (g) / pc	10
ASR- 9	9	7	1.0 (g) / pc	10
ASR-11	11	9	1.0 (g) / pc	10
ASR-13	12.7	10.7	1.2 (g) / pc	10
ASR-14.5	14.7	12.8	1.1 (g) / pc	10
ASR-16	15.9	13.9	1.3 (g) / pc	10
ASR-19	19.1	17.1	1.4 (g) / pc	10

- Material: Nylon 66 UL94V-2